



INSTALLATION INSTRUCTIONS



LEXUS OVERLAND CAT-BACK

PART NO. 19544

BILL OF MATERIALS:

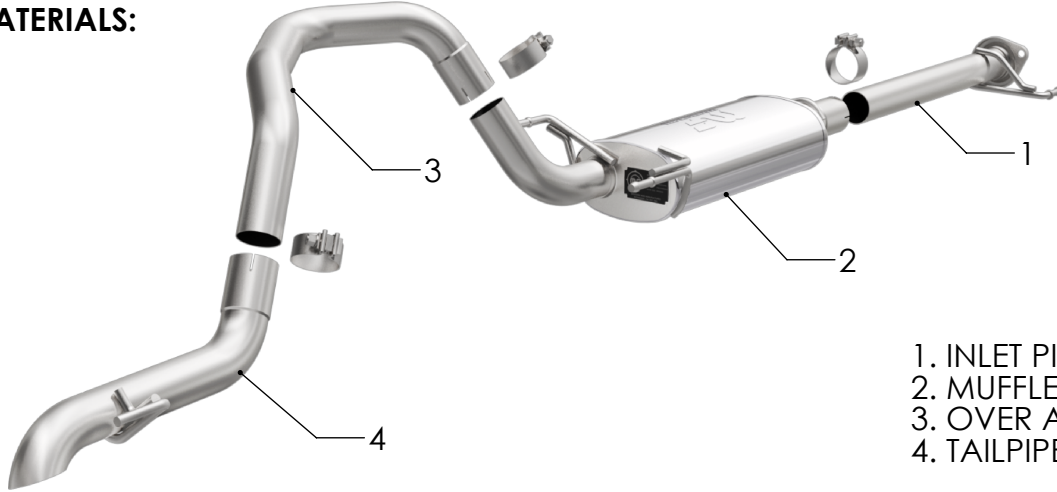

- 1. INLET PIPE ASSY.
- 2. MUFFLER ASSY.
- 3. OVER AXLE PIPE
- 4. TAILPIPE ASSY.



WEAR SAFETY GLASSES



READ INSTRUCTIONS THOROUGHLY BEFORE INSTALLING PRODUCT



SPRAY LUBRICANT

To ease removal of existing exhaust components (especially on older vehicles) spray penetrating lubricant on all fasteners and hangers/insulators that will be loosened or removed and let soak before disassembly.

HARDWARE KIT:

- 1. [3] 2.50" Torca Clamp

MINIMUM REQUIRED TOOLS:



13mm



Hanger Tool (Or Pry Bar)

MAGNAFLOW RECOMMENDS PROFESSIONAL INSTALLATION ON ALL THEIR PRODUCTS



WARNING: When working on, under, or around any vehicle exercise caution. Please allow the vehicle's exhaust system to cool before removal, as exhaust system temperatures may cause severe burns. If working without a lift always consult vehicle manual for correct lifting specifications. Always wear safety glasses and ensure a safe work area. Serious injury or death could occur if safety measures are not followed.

ATTENTION: Always install any supplied band or U-bolt clamps to the proper torque specifications of 40-45 ft-lb for band clamps and 30-35 ft-lb for U-bolt clamps. Over tightening will result in the clamps breaking and will NOT be warranted by MagnaFlow.

INSTALLATION INSTRUCTIONS

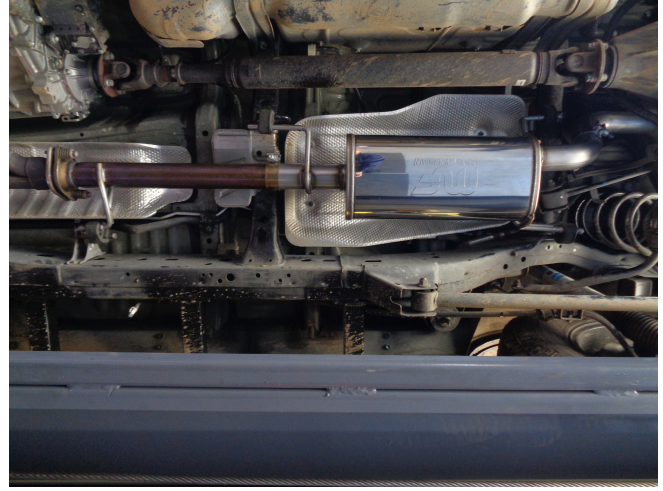

hardware. with the supplied



Working front to rear disengage all welded hangers from the rubber insulators and remove the system. (Retain the insulators as they will be needed to mount the new MAGNAFLOW system.)

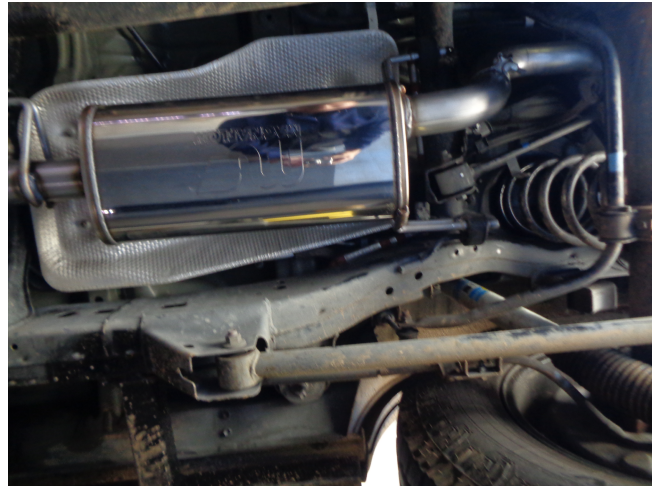

INSTALLATION INSTRUCTIONS



Next, attach the Overaxle pipe to the muffler Assembly and loosely tighten.



Using the OE rubber insulators install the tailpipe assemblies to the Over Axle Pipe fitting the hangers into the installed hanger brackets.



Once a final position has been chosen for the new exhaust system, evenly tighten all clamps from front to rear using the torque specifications on page one of the instructions. Inspect all fasteners after 25-50 miles of operation and re-tighten if necessary.