



# INSTALLATION INSTRUCTIONS



2020 FORD F-250/350 SUPER DUTY 7.3L | PART NO. 19530

## BILL OF MATERIALS:

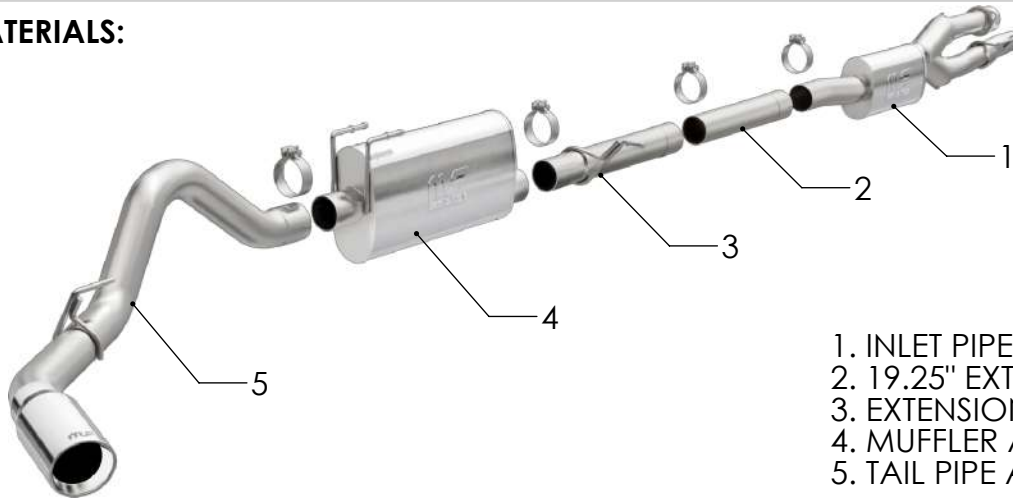

- 1. INLET PIPE ASSEMBLY
- 2. 19.25" EXTENSION PIPE
- 3. EXTENSION PIPE ASSY.
- 4. MUFFLER ASSEMBLY
- 5. TAIL PIPE ASSEMBLY



WEAR SAFETY GLASSES



READ INSTRUCTIONS THOROUGHLY BEFORE INSTALLING PRODUCT



SPRAY LUBRICANT

To ease removal of existing exhaust components (especially on older vehicles) spray penetrating lubricant on all fasteners and hangers/insulators that will be loosened or removed and let soak before disassembly.

## HARDWARE KIT:

- 1. [4] 3.50" Clamp

## MINIMUM REQUIRED TOOLS:



10, 13, 15 mm



Hanger Tool (Or Pry Bar)

## MAGNAFLOW RECOMMENDS PROFESSIONAL INSTALLATION ON ALL THEIR PRODUCTS



**WARNING:** When working on, under, or around any vehicle exercise caution. Please allow the vehicle's exhaust system to cool before removal, as exhaust system temperatures may cause severe burns. If working without a lift always consult vehicle manual for correct lifting specifications. Always wear safety glasses and ensure a safe work area. Serious injury or death could occur if safety measures are not followed.

**ATTENTION:** Always install any supplied band or U-bolt clamps to the proper torque specifications of 40-45 ft-lb for band clamps and 30-35 ft-lb for U-bolt clamps. Over tightening will result in the clamps breaking and will NOT be warranted by MagnaFlow.

## INSTALLATION INSTRUCTIONS



Step 1: To remove the OEM system loosen the clamp at the inlet pipe junction to the catalytic converters. Next, unbolt the flange coupling at the other inlet pipe.



Step 2: Next loosen the clamp rearward of the OEM resonator. Detach all welded hangers from the rubber insulators. The system may now be removed. Be sure to retain all mounting hardware as it will be needed to install your new MAGNAFLOW system



Step 4: Begin installing your new system by loosely attaching the Muffler Assembly to the catalytic converter outlet pipes using the OEM hardware. Engage the welded hanger to the rubber insulator.



Step 5: At this point, if required, add the 19.25" Extension Pipe using a supplied clamp. Next, Loosely attach the Extension Pipe Assembly (has welded hangers attached) followed by the Muffler Assembly using the supplied clamps. Engage the welded hangers to the rubber insulators.

Supercab LWB	Crewcab SWB	Crewcab LWB
Cut 4.5" from 19.25" Pipe	Not used	19.25" Pipe

Step 3: The chart above pertains to the 19.25" extension pipe. Determine your vehicles configuration.

LWB = Long Wheel Base  
SWB - Short Wheel Base

## INSTALLATION INSTRUCTIONS



Step 6: Finish by loosely attaching the Tail Pipe Assembly using the supplied clamp. Install the welded hanger to the rubber insulator.



Step 7: Once a final position has been chosen for the new exhaust system, evenly tighten all clamps from front to rear using the torque specifications on page one of these instructions. Inspect all fasteners after 25-50 miles for operation and re-tighten if necessary.