



INSTALLATION INSTRUCTIONS



2015-2018 CHEVY CRUZE 1.4L

PART NO. 19480

BILL OF MATERIALS:

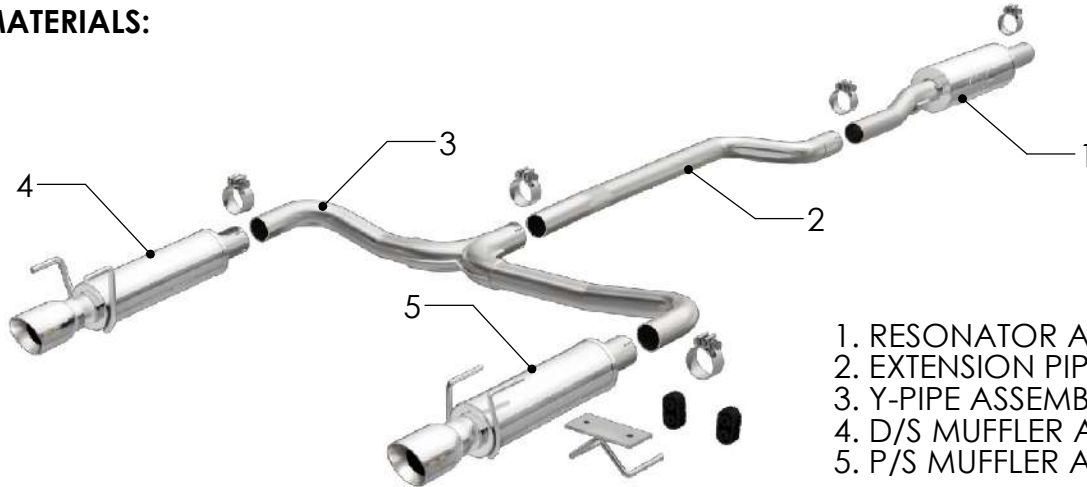

- 1. RESONATOR ASSEMBLY
- 2. EXTENSION PIPE
- 3. Y-PIPE ASSEMBLY
- 4. D/S MUFFLER ASSEMBLY
- 5. P/S MUFFLER ASSEMBLY



WEAR SAFETY GLASSES



READ INSTRUCTIONS THOROUGHLY BEFORE INSTALLING PRODUCT



SPRAY LUBRICANT

To ease removal of existing exhaust components (especially on older vehicles) spray penetrating lubricant on all fasteners and hangers/insulators that will be loosened or removed and let soak before disassembly.

HARDWARE KIT:

- 1. [4] 2.25" Clamp
- 2. [1] 2.38" Clamp
- 3. [1] Hanger Assy
- 4. [2] Rubber Insulator
- 5. [2] M8 Lock Nut
- 6. [2] M8 Washer

MINIMUM REQUIRED TOOLS:



12, 14, 15 mm



Hanger Tool (Or Pry Bar)

MAGNAFLOW RECOMMENDS PROFESSIONAL INSTALLATION ON ALL THEIR PRODUCTS



WARNING: When working on, under, or around any vehicle exercise caution. Please allow the vehicle's exhaust system to cool before removal, as exhaust system temperatures may cause severe burns. If working without a lift always consult vehicle manual for correct lifting specifications. Always wear safety glasses and ensure a safe work area. Serious injury or death could occur if safety measures are not followed.

ATTENTION: Always install any supplied band or U-bolt clamps to the proper torque specifications of 40-45 ft-lb for band clamps and 30-35 ft-lb for U-bolt clamps. Over tightening will result in the clamps breaking and will NOT be warranted by MagnaFlow.

INSTALLATION INSTRUCTIONS



Step 1: To install the MagnaFlow exhaust the OE system must be cut. Measure 3.00" back from the catalytic converter weld, cut at this point and deburr pipe. Working front to rear disengage all welded hangers from the rubber insulators. The OEM exhaust system can now be removed in one piece. Be sure to retain the rubber hanger insulators as they will be needed to install your new MagnaFlow system.



Step 2: Begin installing your new system by sliding the Resonator Assembly over the cut pipe and loosely attaching with the provided 2.38" clamp. Engage the hanger to the rubber insulator.



Step 3: Next loosely fasten the Y-Pipe Assembly to the Resonator Assembly using the supplied 2.25" clamp.



Step 4: Using the existing studs located on the factory frame rail mount the supplied Hanger Assembly with the supplied M8 lock nuts and washers.

INSTALLATION INSTRUCTIONS



Step 5: Next slip the P/S Muffler Assembly onto the Y-Pipe Assembly and loosely fasten with the supplied 2.25" Clamp. Using the supplied Rubber insulators attach the hangers. Fit the D/S Muffler Assembly in the same manner using the supplied clamp and OE rubber insulators.



Step 6: Once a final position has been chosen for the new exhaust system, evenly tighten all clamps from front to rear using the torque specifications on page one of these instructions. Inspect all fasteners after 25-50 miles for operation and re-tighten if necessary.