



INSTALLATION INSTRUCTIONS



STREET CAT-BACK TOYOTA

PART NO. 19410

BILL OF MATERIALS:

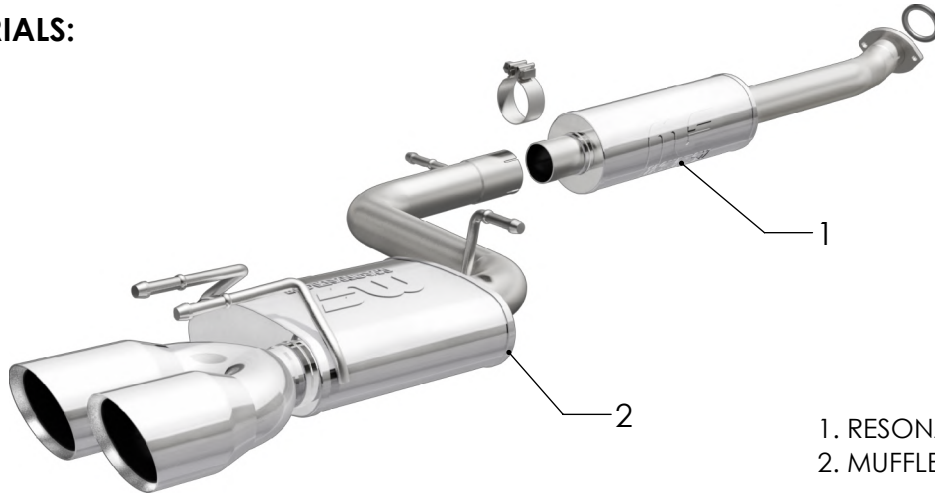

- 1. RESONATOR ASSEMBLY
- 2. MUFFLER ASSEMBLY



WEAR SAFETY GLASSES



READ INSTRUCTIONS THOROUGHLY BEFORE INSTALLING PRODUCT



SPRAY LUBRICANT

To ease removal of existing exhaust components (especially on older vehicles) spray penetrating lubricant on all fasteners and hangers/insulators that will be loosened or removed and let soak before disassembly.

HARDWARE KIT:

- 1.[1] 2.50" Clamp
- 2.[1] Gasket

MINIMUM REQUIRED TOOLS:



13mm, 15 mm



Hanger Tool (Or Pry Bar)

MAGNAFLOW RECOMMENDS PROFESSIONAL INSTALLATION ON ALL THEIR PRODUCTS



WARNING: When working on, under, or around any vehicle exercise caution. Please allow the vehicle's exhaust system to cool before removal, as exhaust system temperatures may cause severe burns. If working without a lift always consult vehicle manual for correct lifting specifications. Always wear safety glasses and ensure a safe work area. Serious injury or death could occur if safety measures are not followed.

ATTENTION: Always install any supplied band or U-bolt clamps to the proper torque specifications of 40-45 ft-lb for band clamps and 30-35 ft-lb for U-bolt clamps. Over tightening will result in the clamps breaking and will NOT be warranted by MagnaFlow.

INSTALLATION INSTRUCTIONS

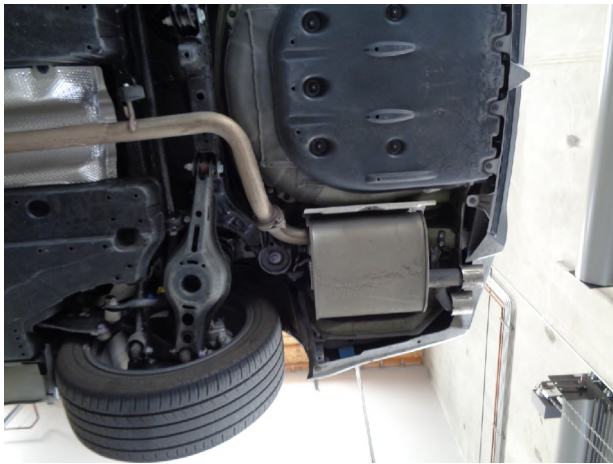

Step 1. To remove the OE exhaust system begin by unfastening the 2 bolt flanges, one located at the front of the vehicle (behind the catalytic converter assy) and one at the rear (by the muffler). Working front to rear disengage the hangers from the rubber insulators and remove the exhaust. Do not damage the rubber insulators and retain front flange hardware as they will be used to install the new exhaust system.

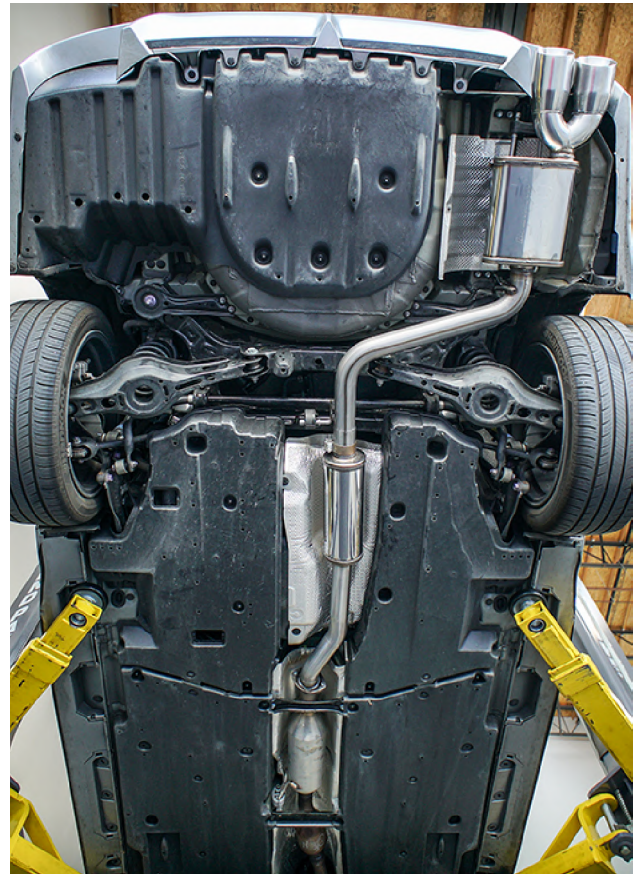

Step 2. Begin installation of the MagnaFlow system by attaching the Resonator Assembly to the outlet of the catalytic converter using the OE fasteners. Next, attach the Muffler Assembly using the supplied 2.50" clamp and engaging the hangers into the rubber insulators. (Leave all clamp and fasteners loose for final adjustment of the complete system.)



Step 3. Once a final position has been chosen for the new exhaust system, evenly tighten all clamps from front to rear using the torque specifications on page one of the instructions. Inspect all fasteners after 25-50 miles of operation and re-tighten if necessary.