



INSTALLATION INSTRUCTIONS



2011-2018 CHEVROLET SILVERADO/GMC SIERRA 6.0L | PART NO. 19376

BILL OF MATERIALS:

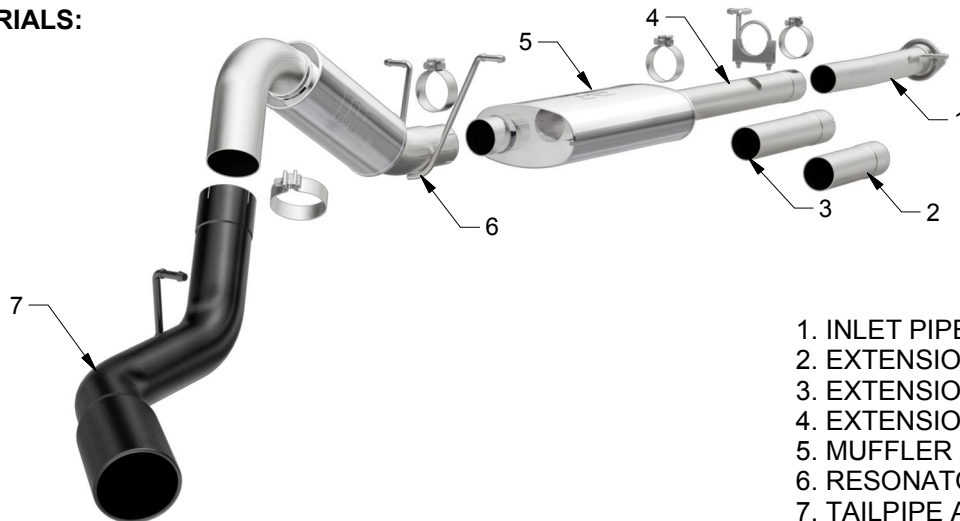

- 1. INLET PIPE ASSEMBLY
- 2. EXTENSION PIPE (13.0")
- 3. EXTENSION PIPE (17.0")
- 4. EXTENSION PIPE (26.5")
- 5. MUFFLER ASSEMBLY
- 6. RESONATOR PIPE ASSEMBLY
- 7. TAILPIPE ASSEMBLY



WEAR SAFETY GLASSES



READ INSTRUCTIONS THOROUGHLY BEFORE INSTALLING PRODUCT

SHOP SUPPLIES:



SPRAY LUBRICANT

To ease removal of existing exhaust components (especially on older vehicles) spray penetrating lubricant on all fasteners and hangers/insulators that will be loosened or removed and let soak before disassembly.

HARDWARE KIT:

- 1.[1] 3.50" Hanger Clamp Assy.
- 2.[3] 3.50" Clamp
- 3.[1] 4.00" Clamp

MINIMUM REQUIRED TOOLS:



15mm



Hanger Tool (Or Pry Bar)



Sawzall or other cutting device.

MAGNAFLOW RECOMMENDS PROFESSIONAL INSTALLATION ON ALL THEIR PRODUCTS



WARNING: When working on, under, or around any vehicle exercise caution. Please allow the vehicle's exhaust system to cool before removal, as exhaust system temperatures may cause severe burns. If working without a lift always consult vehicle manual for correct lifting specifications. Always wear safety glasses and ensure a safe work area. Serious injury or death could occur if safety measures are not followed.

ATTENTION: Always install any supplied band or U-bolt clamps to the proper torque specifications of 40-45 ft-lbs for band clamps and 30-35 ft-lbs for U-bolt clamps. Over tightening will result in the clamp breaking and will NOT be warranted by MagnaFlow.

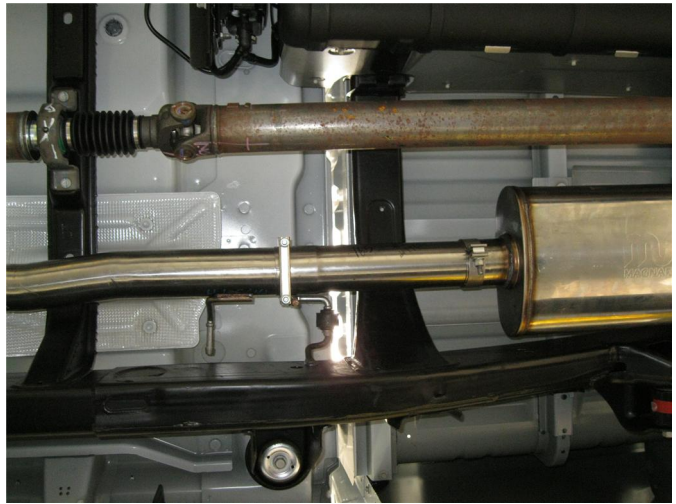

Step 2. Before installing your new system ascertain which cab and bed configuration your vehicle has. For the SC/LB you will need to cut 10.00" from the outlet on the Inlet Pipe Assembly. Begin installation of the new system by attaching the Inlet Pipe Assembly to the catalytic converter using the OEM fasteners, For the Extended Cab/Short Bed truck no Extension Pipe is needed between the Inlet and Muffler Assembly. Some of the following configurations will require the Hanger Clamp Assembly to be used in conjunction with an appropriate Extension Pipe which is to be installed between the Inlet Pipe Assembly and the Muffler Assembly using the supplied 3.50" Clamps.

- SC/LB - Cut Inlet Pipe only, no extension, no Hanger.
- EC/SB - Inlet Pipe only, no extension, with Hanger.
- CC/SB - Inlet Pipe, 13.00" extension, with Hanger.
- EC/LB - Inlet Pipe, 17.00" extension, with Hanger.
- CC/LB - Inlet Pipe, 26.50" extension, with Hanger.

(Leave all clamps and fasteners loose for final adjustment of the complete system.)

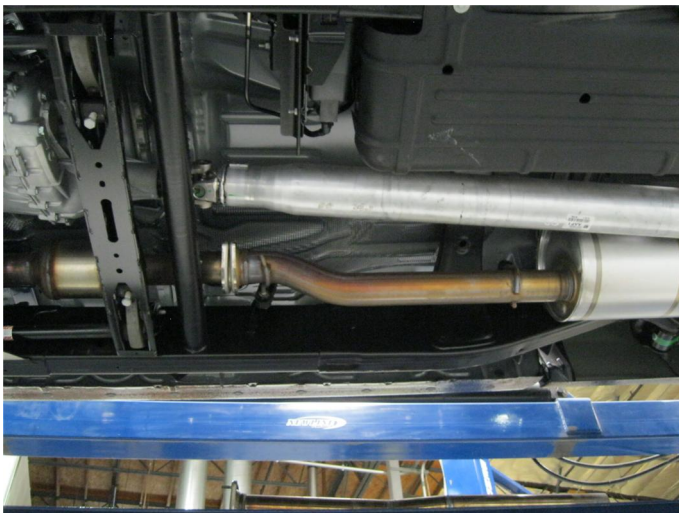

Step 1. To remove the OEM exhaust system, you will need to cut the pipe behind the muffler before it goes over the axle. Disengage the welded hangers from the rubber insulators and remove the tailpipe. Next remove the fasteners from the two bolt fange behind the catalytic converter. Do not damage or discard the fasteners or rubber insulators, as they will be re-used to mount the new system. Disengage the remainder of the hangers and remove the system.

INSTALLATION INSTRUCTIONS

Step 3. Install the Muffler to the Inlet Pipe Assembly/Extension Pipe using the supplied 3.50" clamp.

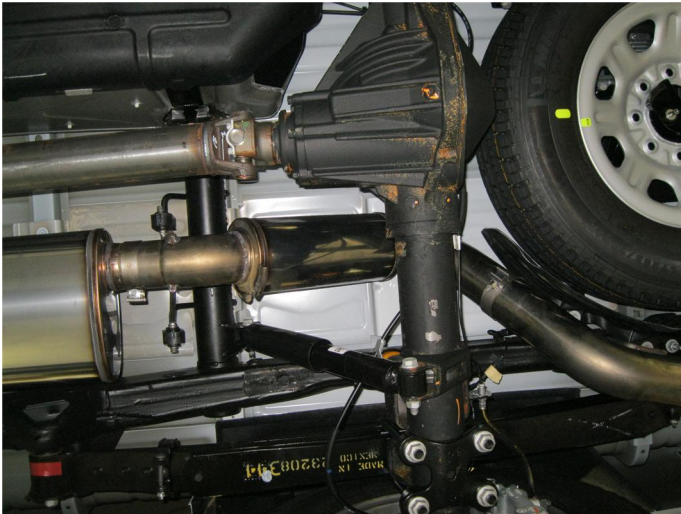

Step 4. Next install the over axle Resonator assembly to the Muffler in the similar fashion using the supplied 3.50" clamp, fitting the welded hangers into the rubber insulators.



Step 5. Finish by installing the Tail Pipe Assembly to the over axle Resonator assembly using the supplied 4.00" clamp, fitting the welded hanger into the rubber insulator.

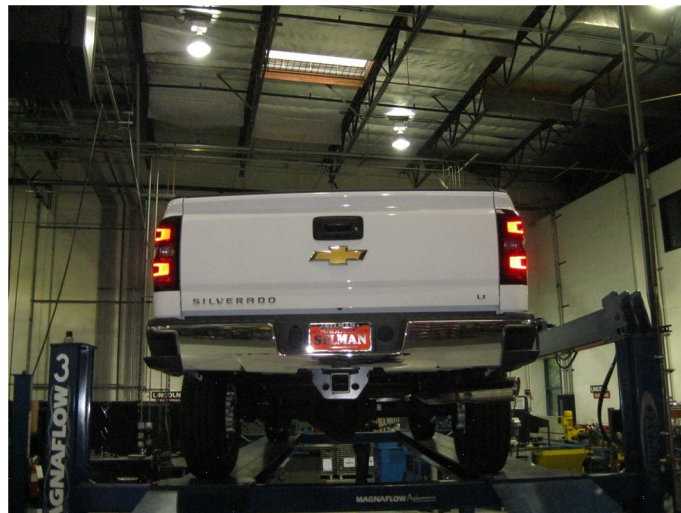

Step 6. Once a final position has been chosen for the new exhaust system, evenly tighten all clamps from front to rear using the torque specifications on page one of the instructions. Inspect all fasteners after 25-50 miles of operation and re-tighten if necessary.