



# INSTALLATION INSTRUCTIONS



2016 CHEVROLET CAMARO 6.2L | PART NO. 19339

## BILL OF MATERIALS:

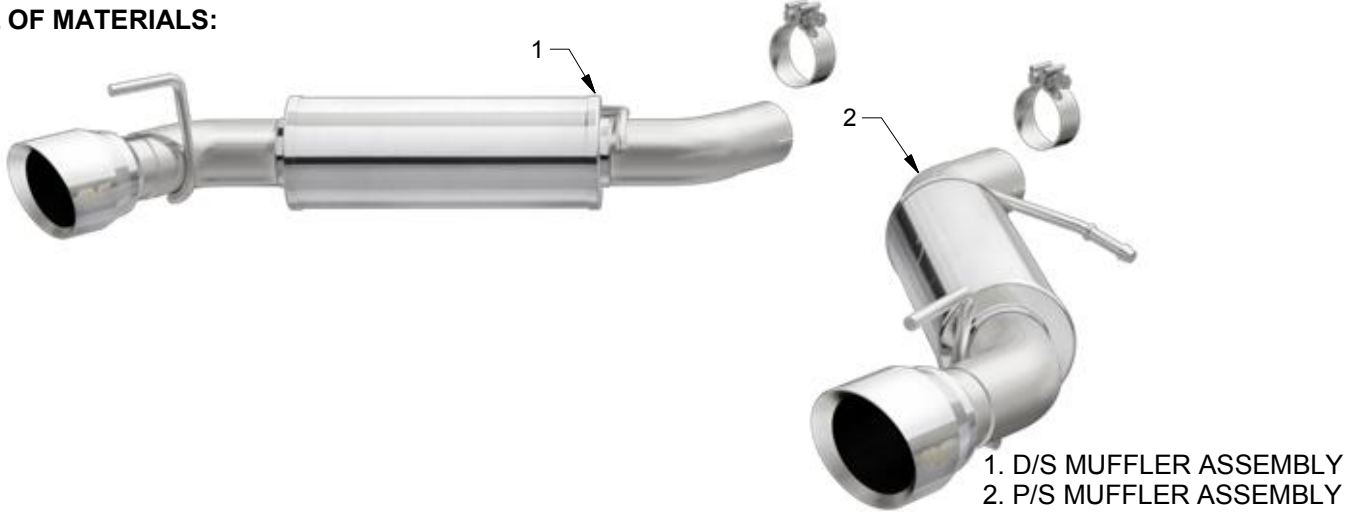

- 1. D/S MUFFLER ASSEMBLY
- 2. P/S MUFFLER ASSEMBLY



WEAR SAFETY GLASSES



READ INSTRUCTIONS THOROUGHLY BEFORE INSTALLING PRODUCT

## SHOP SUPPLIES:



SPRAY LUBRICANT

To ease removal of existing exhaust components (especially on older vehicles) spray penetrating lubricant on all fasteners and hangers/insulators that will be loosened or removed and let soak before disassembly.

## HARDWARE KIT:

- 1. [2] 2.75" Clamp

## MINIMUM REQUIRED TOOLS:



8mm, 15mm



Hanger Tool (Or Pry Bar)



Sawzall or similar cutting device

## MAGNAFLOW RECOMMENDS PROFESSIONAL INSTALLATION ON ALL THEIR PRODUCTS



**WARNING:** When working on, under, or around any vehicle exercise caution. Please allow the vehicle's exhaust system to cool before removal, as exhaust system temperatures may cause severe burns. If working without a lift always consult vehicle manual for correct lifting specifications. Always wear safety glasses and ensure a safe work area. Serious injury or death could occur if safety measures are not followed.

**ATTENTION:** Always install any supplied band or V-band clamps to the proper torque specifications of 40-45 ft-lbs for band clamps and 70 in-lbs for V-band clamps. Over tightening will result in the clamp breaking and will NOT be warranted by MagnaFlow.

## INSTALLATION INSTRUCTIONS

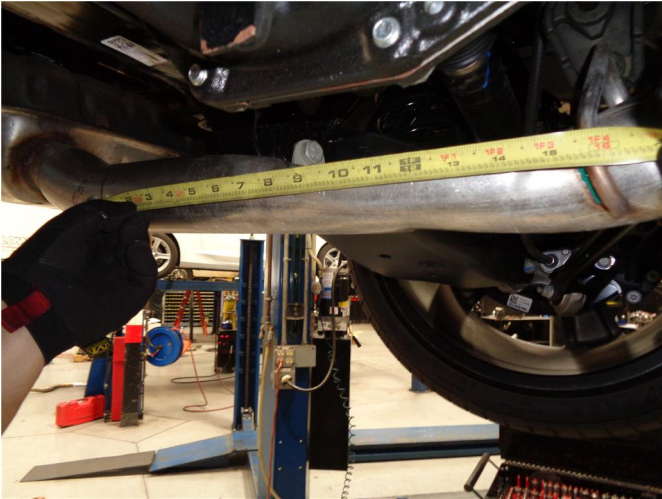

**Step 1.** It is necessary to cut the factory exhaust system to install the new Magnaflow unit. To do this measure rearward from the welded hanger forward of the rear muffler. Measure and cut 16" for the drivers side and 17" for the passengers side as shown. Deburr the cut pipes to facilitate installation of the new system.

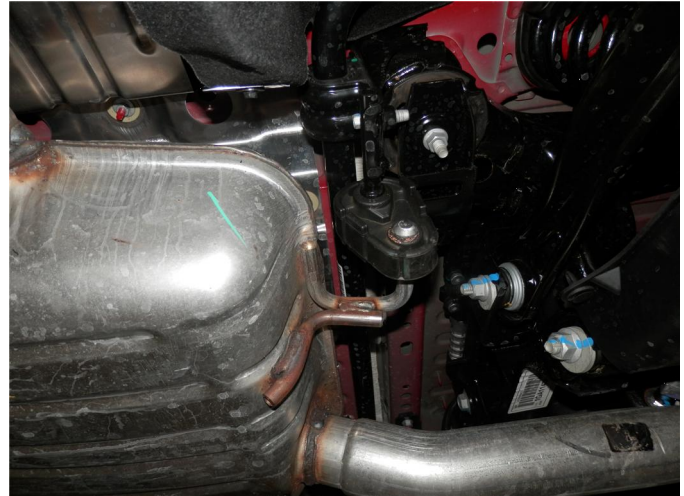
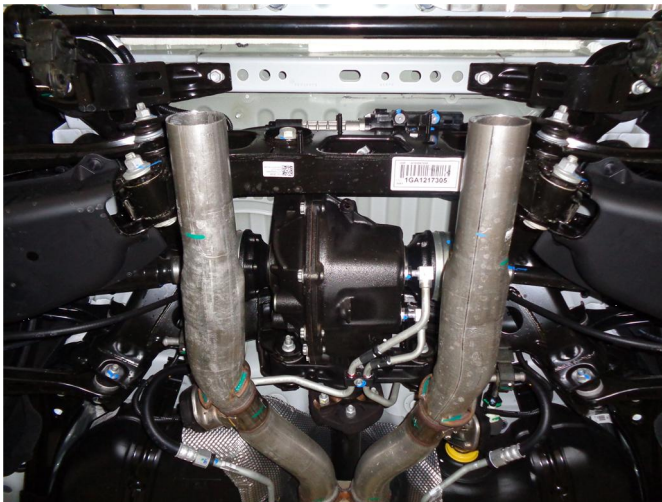

**Step 2.** Working front to rear disengage all welded hangers from the rubber insulators and remove the muffler assembly. (Retain the insulators as they will be needed to mount the new MAGNAFLOW system.)



**Step 3.** Begin installation of the new system by sliding the D/S Muffler Assembly inlet onto the cut outlet of the OEM exhaust and loosely fasten with the supplied 2.75" clamp. Fit the hangers into the rubber insulators.

## INSTALLATION INSTRUCTIONS



**Step 4.** Install the P/S Muffler Assembly in the same manner. Leave all clamps loose for final adjustment of the system.



**Step 5.** Once a final position has been chosen for the new exhaust system, evenly tighten all clamps from front to rear using the torque specifications on page one of the instructions. Inspect all fasteners after 25-50 miles of operation and re-tighten if necessary.