



INSTALLATION INSTRUCTIONS



2016 CHEVROLET CAMARO 3.6L COMP | PART NO. 19332

BILL OF MATERIALS:

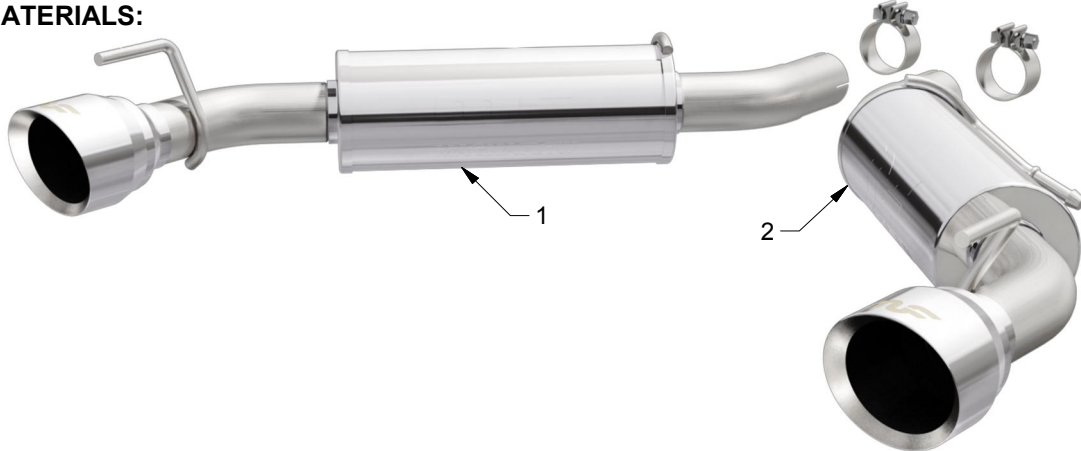

- 1. D/S MUFFLER ASSEMBLY
- 2. P/S MUFFLER ASSEMBLY



WEAR SAFETY GLASSES



READ INSTRUCTIONS THOROUGHLY BEFORE INSTALLING PRODUCT

SHOP SUPPLIES:



SPRAY LUBRICANT

To ease removal of existing exhaust components (especially on older vehicles) spray penetrating lubricant on all fasteners and hangers/insulators that will be loosened or removed and let soak before disassembly.

HARDWARE KIT:

- 1.[2] 2.25" Clamp

MINIMUM REQUIRED TOOLS:



15mm



Hanger Tool (Or Pry Bar)



Cutting Device

MAGNAFLOW RECOMMENDS PROFESSIONAL INSTALLATION ON ALL THEIR PRODUCTS



WARNING: When working on, under, or around any vehicle exercise caution. Please allow the vehicle's exhaust system to cool before removal, as exhaust system temperatures may cause severe burns. If working without a lift always consult vehicle manual for correct lifting specifications. Always wear safety glasses and ensure a safe work area. Serious injury or death could occur if safety measures are not followed.

ATTENTION: Always install any supplied band or U-bolt clamps to the proper torque specifications of 40-45 ft-lbs for band clamps and 30-35 ft-lbs for U-bolt clamps. Over tightening will result in the clamp breaking and will NOT be warranted by MagnaFlow.

INSTALLATION INSTRUCTIONS



Step 1. To remove the OEM tail section of the exhaust you will need to carefully cut the OEM tail pipes. For the drivers side measure 13" rearward of the welded hanger brace behind the exhaust control valve as shown. Be Sure to deburr all cut edges.



Step 2. Cut the passengers side tail pipe in a similar fashion measuring 15" rearward of the welded hanger as show. Again, deburr cut edge. You are now ready to install your new MAGNAFLOW system.

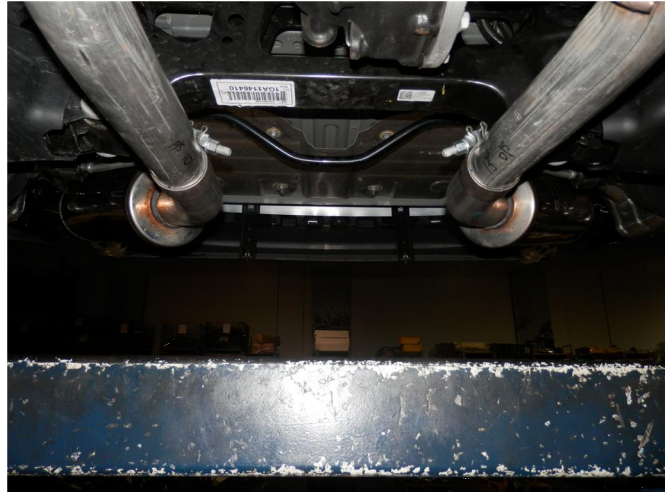

Step 3. Begin installation by loosely attaching both drivers side and passengers side Muffler Assemblies to the outlet of the cut pipes using the supplied clamps and fitting the hanger into the rubber insulator. Leave all clamps loose until final adjustment



Step 4. Once a final position has been chosen for the new exhaust system, evenly tighten all clamps from front to rear using the torque specifications on page one of the instructions. Replace the shield and cross brace. Inspect all fasteners after 25-50 miles of operation and re-tighten if necessary.