



# INSTALLATION INSTRUCTIONS



'12-'16 JEEP WRANGLER 3.6L BLACK | PART NO. 19327

## BILL OF MATERIALS:

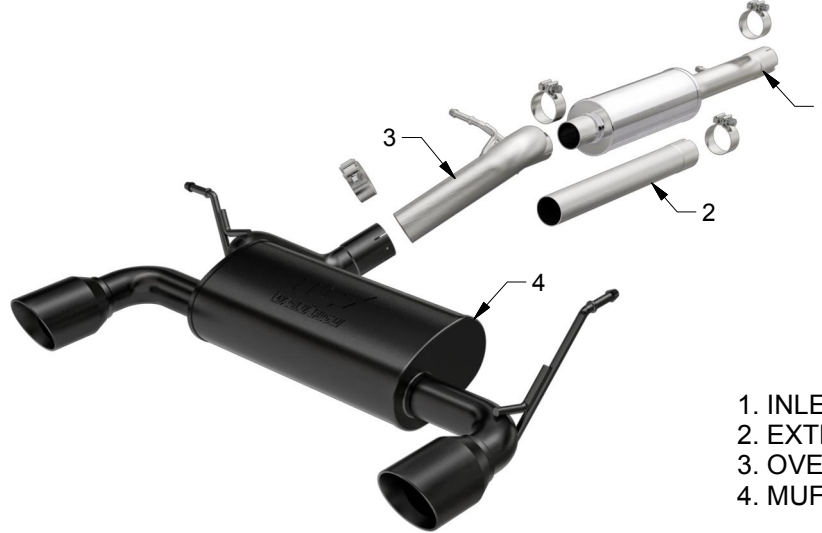

- 1. INLET RESONATOR ASSY
- 2. EXTENSION PIPE
- 3. OVER-AXLE PIPE ASSY
- 4. MUFFLER SUB ASSY



WEAR SAFETY GLASSES



READ INSTRUCTIONS THOROUGHLY BEFORE INSTALLING PRODUCT

## SHOP SUPPLIES:



SPRAY LUBRICANT

To ease removal of existing exhaust components (especially on older vehicles) spray penetrating lubricant on all fasteners and hangers/insulators that will be loosened or removed and let soak before disassembly.

## HARDWARE KIT:

- 1.[4] 2.50" Clamp

## MINIMUM REQUIRED TOOLS:



13, 15mm



Hanger Tool (Or Pry Bar)

## MAGNAFLOW RECOMMENDS PROFESSIONAL INSTALLATION ON ALL THEIR PRODUCTS



**WARNING:** When working on, under, or around any vehicle exercise caution. Please allow the vehicle's exhaust system to cool before removal, as exhaust system temperatures may cause severe burns. If working without a lift always consult vehicle manual for correct lifting specifications. Always wear safety glasses and ensure a safe work area. Serious injury or death could occur if safety measures are not followed.

**ATTENTION:** Always install any supplied band or U-bolt clamps to the proper torque specifications of 40-45 ft-lbs for band clamps and 30-35 ft-lbs for U-bolt clamps. Over tightening will result in the clamp breaking and will NOT be warranted by MagnaFlow.

## INSTALLATION INSTRUCTIONS



**Step 1.** Begin removal of the OEM exhaust system by loosening the band clamp attaching the exhaust to the catalytic converter. Do not discard or damage the OEM fasteners or rubber insulators as they will be used to install the new system.



**Step 2.** Disengage hangers from rubber insulators and remove the OEM exhaust.



**Step 3.** Begin installation of your new MAGNAFLOW system by attaching the Resonator Assembly to the catalytic converter outlet using the OEM band clamp. Align the locating peg with the notch in the inlet pipe. Engage the welded hanger to the rubber insulators. Keep all fasteners and clamps loose until final adjustment.

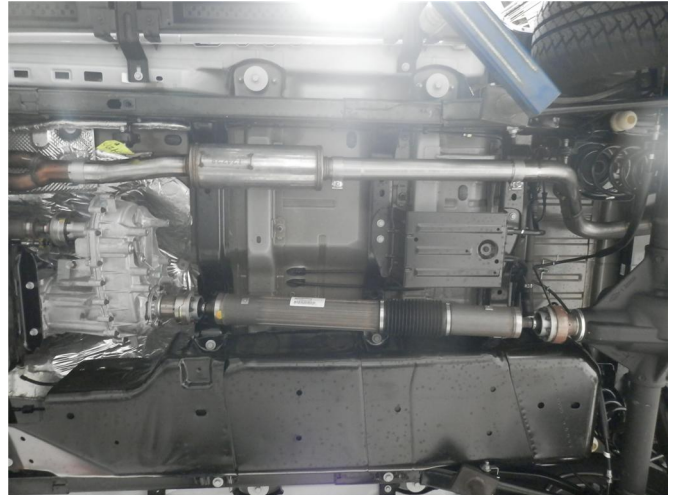

**Step 4.** The included Extension Pipe is required for the four door model only. It is to be installed between the Resonator Assembly and the Over-Axle Pipe Assembly. If you have the two door this pipe may be discarded.

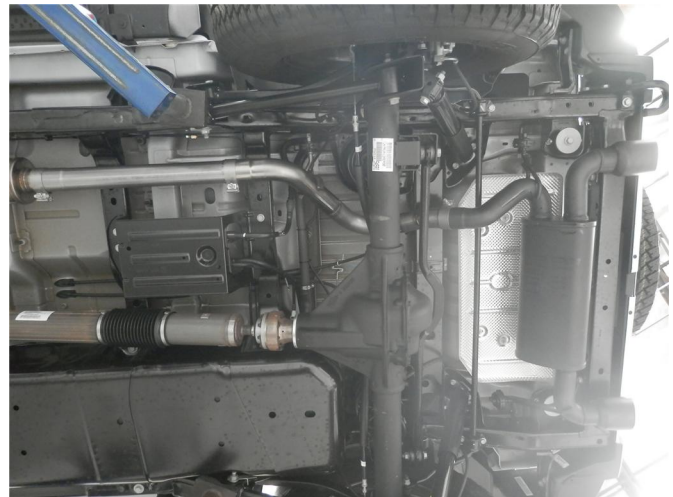

**Step 5.** Next loosely install the Over-Axle Pipe Assembly and the Muffler Assembly using the supplied clamps. Locate all welded hangers to the rubber insulators.

## INSTALLATION INSTRUCTIONS



**Step 6.** Once a final position has been chosen for the new exhaust system, evenly tighten all clamps from front to rear using the torque specifications on page one of the instructions. Inspect all fasteners after 25-50 miles of operation and re-tighten if necessary.