



INSTALLATION INSTRUCTIONS



2016 CHEVROLET CAMARO 2.0L

PART NO. 19309

BILL OF MATERIALS:

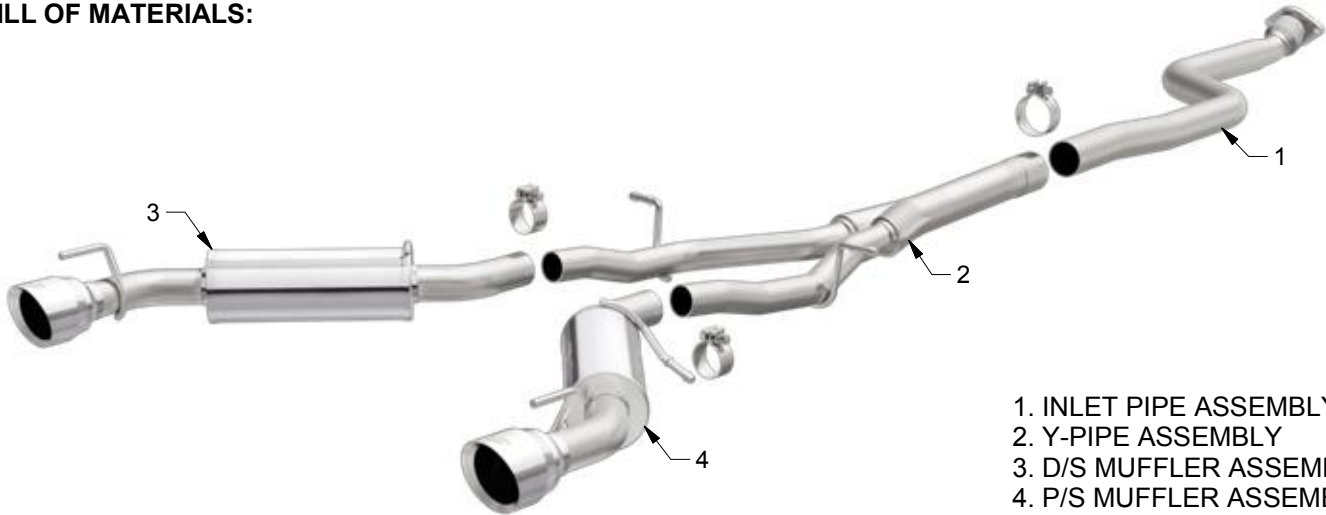

- 1. INLET PIPE ASSEMBLY
- 2. Y-PIPE ASSEMBLY
- 3. D/S MUFFLER ASSEMBLY
- 4. P/S MUFFLER ASSEMBLY



WEAR SAFETY GLASSES



READ INSTRUCTIONS THOROUGHLY BEFORE INSTALLING PRODUCT

SHOP SUPPLIES:



SPRAY LUBRICANT

To ease removal of existing exhaust components (especially on older vehicles) spray penetrating lubricant on all fasteners and hangers/insulators that will be loosened or removed and let soak before disassembly.

HARDWARE KIT:

- 1.[1] 3.00" Clamp
- 1.[2] 2.25" Clamp

MINIMUM REQUIRED TOOLS:



15mm
13mm



Hanger Tool
(Or Pry Bar)

MAGNAFLOW RECOMMENDS PROFESSIONAL INSTALLATION ON ALL THEIR PRODUCTS



WARNING: When working on, under, or around any vehicle exercise caution. Please allow the vehicle's exhaust system to cool before removal, as exhaust system temperatures may cause severe burns. If working without a lift always consult vehicle manual for correct lifting specifications. Always wear safety glasses and ensure a safe work area. Serious injury or death could occur if safety measures are not followed.

ATTENTION: Always install any supplied band or U-bolt clamps to the proper torque specifications of 40-45 ft-lbs for band clamps and 30-35 ft-lbs for U-bolt clamps. Over tightening will result in the clamp breaking and will NOT be warranted by MagnaFlow.

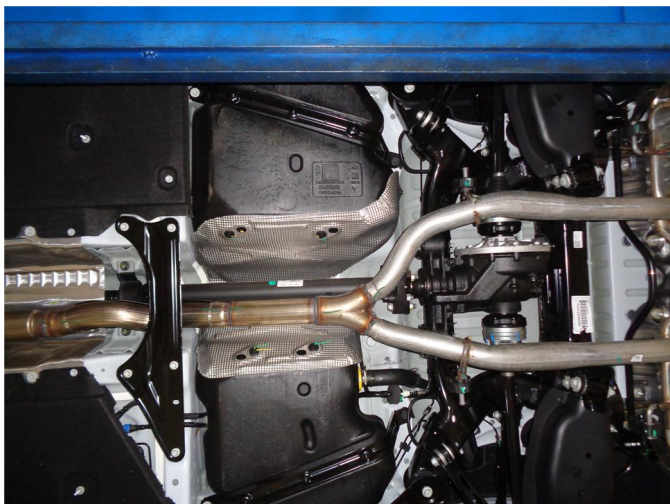

Step 2. Begin installation of your new MAGNAFLOW system by loosely bolting the Inlet Pipe Assembly to the catalytic converter outlet flange using the OE fasteners.

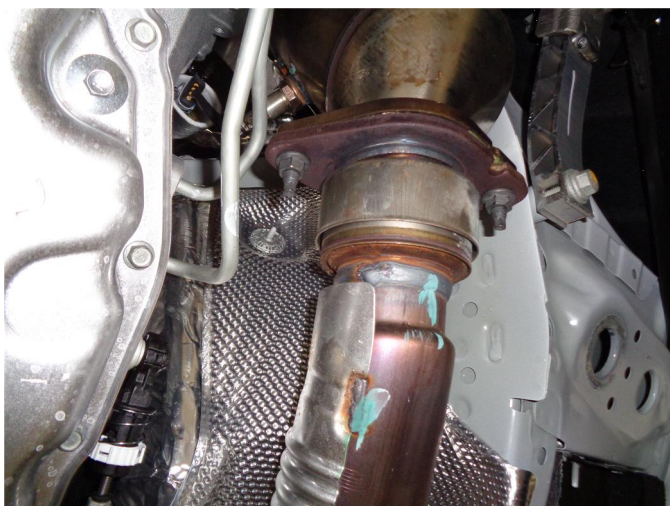

Step 1. To remove the OEM exhaust you will need to unbolt and remove the cross brace shown. Now you can unbolt the OEM exhaust from the catalytic converter flange junction. Disengage all welded hangers from the rubber insulators. Retain rubber insulators as they will be needed to install your new MAGNAFLOW system. The OEM system can now be removed.



Step 3. Next, loosely install the Y-Pipe Assembly using the supplied 3.00" clamps. Locate the welded hangers to the rubber insulators.



Step 4. Loosely install the drivers and passengers side Muffler Assemblies using the supplied 2.25" clamps. Engage the welded hangers to the rubber insulators.

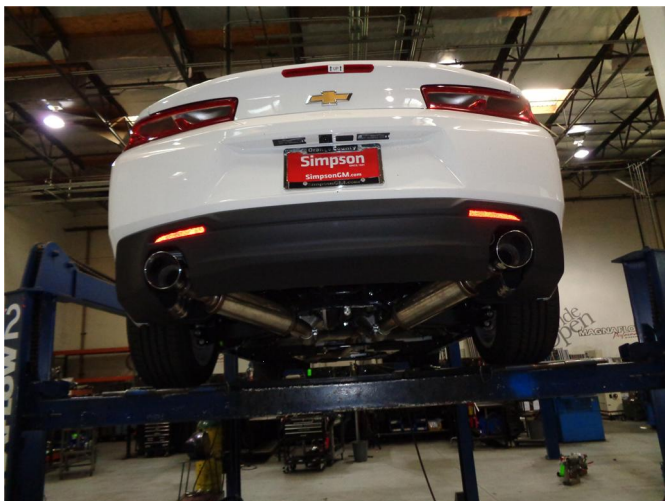

Step 5. Once a final position has been chosen for the new exhaust system, evenly tighten all clamps from front to rear using the torque specifications on page one of the instructions. Inspect all fasteners after 25-50 miles of operation and re-tighten if necessary.