



INSTALLATION INSTRUCTIONS



2015 DODGE CHARGER 3.6L

PART NO. 19225

BILL OF MATERIALS:

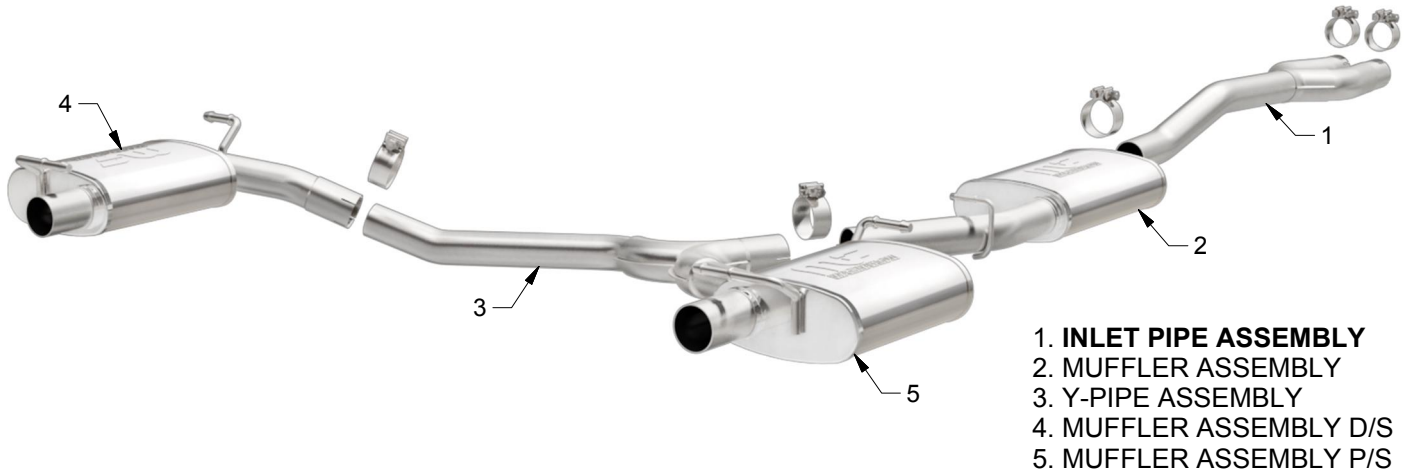

WEAR SAFETY
GLASSES



READ INSTRUCTIONS
THOROUGHLY BEFORE
INSTALLING PRODUCT

SHOP SUPPLIES:



SPRAY LUBRICANT

To ease removal of existing exhaust components (especially on older vehicles) spray penetrating lubricant on all fasteners and hangers/insulators that will be loosened or removed and let soak before disassembly.

HARDWARE KIT:

- [2] 2.25" Torca Clamp
- [4] 2.50" Torca Clamp

MINIMUM REQUIRED TOOLS:



Hanger Tool
(Or Pry Bar)



15mm
13mm

INSTALLATION INSTRUCTIONS

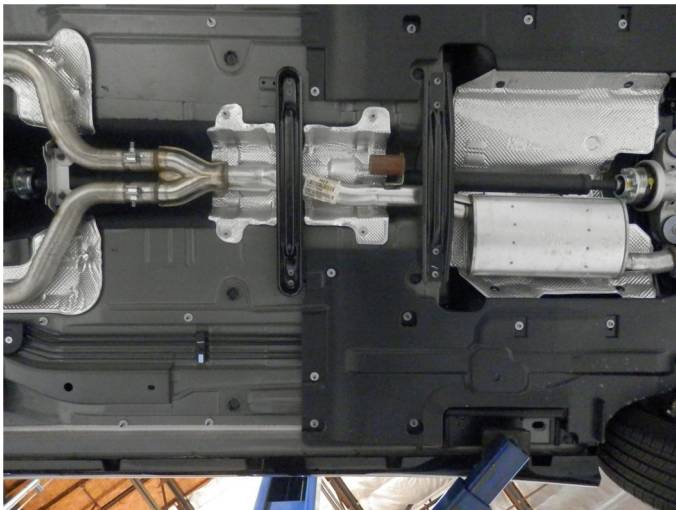

Step 1. To allow for removal of the OEM exhaust you will need to remove the underbody braces. Begin the removal of the OEM system by unfastening the inlet pipe inlets at the factory clamp locations. Un-clip the ground strap from the passenger side hanger and working rearward (with the exhaust supported) extract the hangers from the rubber insulators and remove the OEM exhaust. Do not discard or damage the rubber insulators as they will be used to install the new exhaust system.

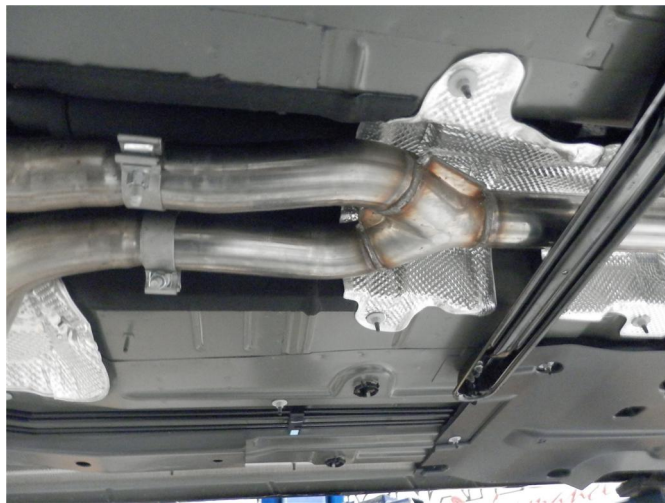

Step 2. Begin installation of the new system by attaching the Inlet Pipe Assembly to the outlets of the OEM system using the supplied 2.25" clamps. Leave all clamps loose for final adjustment.

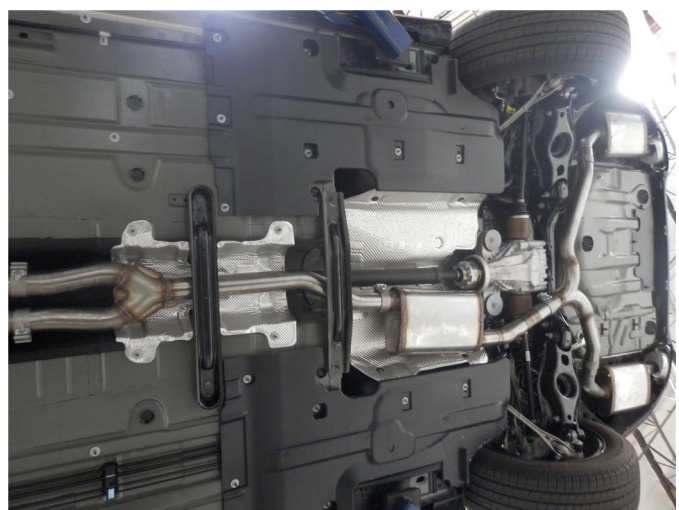

Step 3. Next loosely attach the Muffler Assembly inlet pipe to the Inlet Pipe Assembly outlet using the supplied 2.50" clamp. Engage the welded hanger to the OEM rubber insulator.



Step 4. Install the Y-Pipe Assembly, drivers and passengers side Muffler Assemblies in a similar fashion using the supplied 2.50" clamp. Locate each muffler outlet to each OEM tip mounted in the vehicles valance. Engage the welded hanger to the OEM rubber insulators.

INSTALLATION INSTRUCTIONS



Step 5. Re-attach the ground strap to the hanger. Finish the installation mounting underbody braces.

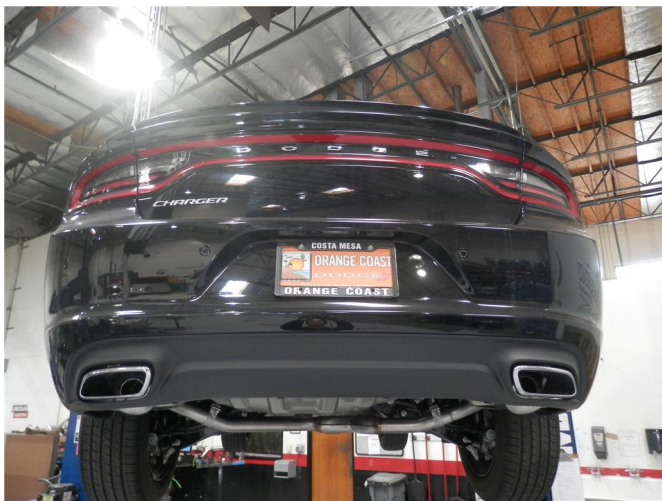

Step 6. Once a final position has been chosen for the new exhaust system, evenly tighten all clamps from front to rear using the torque specifications on page one of the instructions. Inspect all fasteners after 25-50 miles of operation and re-tighten if necessary.