



INSTALLATION INSTRUCTIONS



2015 FORD F-150 2.7L

PART NO. 19056

BILL OF MATERIALS:

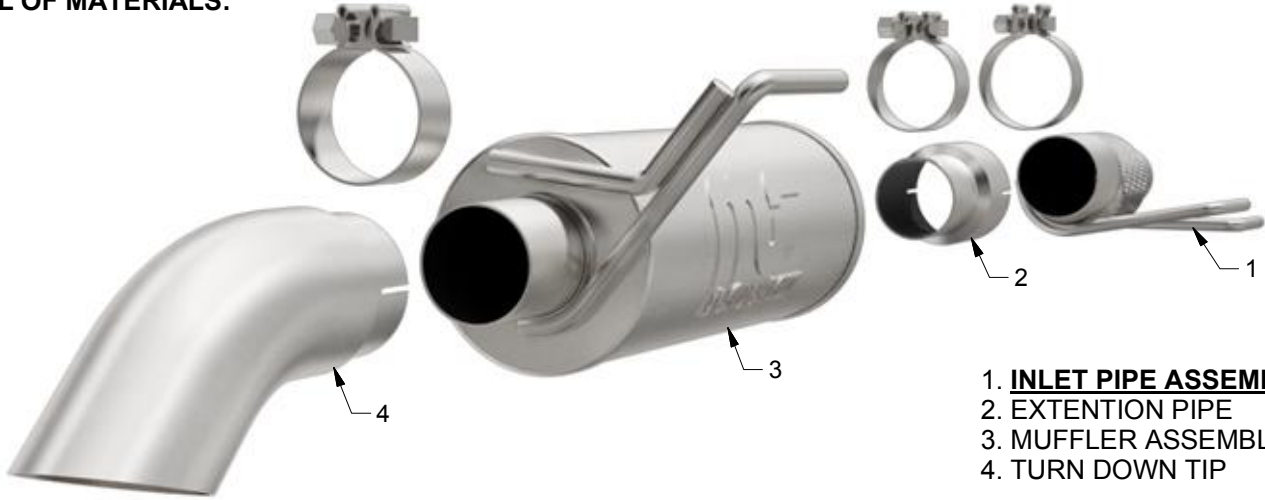

- 1. **INLET PIPE ASSEMBLY**
- 2. **EXTENTION PIPE**
- 3. **MUFFLER ASSEMBLY**
- 4. **TURN DOWN TIP**



WEAR SAFETY
GLASSES



READ INSTRUCTIONS
THOROUGHLY BEFORE
INSTALLING PRODUCT

SHOP SUPPLIES:



SPRAY LUBRICANT

To ease removal of existing exhaust components (especially on older vehicles) spray penetrating lubricant on all fasteners and hangers/insulators that will be loosened or removed and let soak before disassembly.

HARDWARE KIT:

- 1. [1] 3.00" Clamp
- 2. [2] 2.50" Clamp

MINIMUM REQUIRED TOOLS:



15mm



Hanger Tool
(Or Pry Bar)

INSTALLATION INSTRUCTIONS



Step 1. To remove the OEM exhaust system, loosen the clamp attaching the systems inlet pipes to the catalytic converter outlet pipes. Disengage all welded hangers from the OEM rubber insulators. Do not discard the OEM fasteners or damage the rubber insulators as they will be needed to mount your new MAGNAFLOW system.

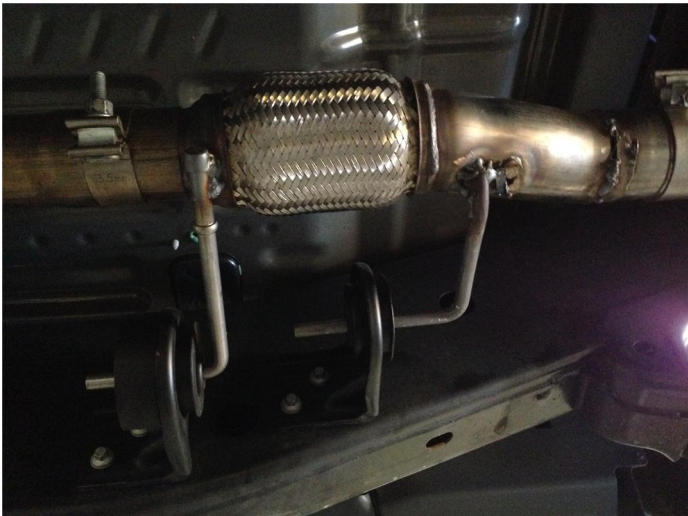

Step 2. Install the new system by attaching the Inlet Pipe Assembly to the OEM catalytic converter outlet pipes using the existing clamp and hardware. Locate the welded hanger to the rubber insulator. Leave all clamps and fasteners loose for final adjustment of the complete system once installed.



Step 3. Install the Extension Pipe between the Inlet Pipe Assembly and the Muffler Assembly using the supplied 3.00" and 2.50" clamps. Engage the welded hanger to the rubber insulator.



Step 4. Install both the Turn Down Tip with the supplied 2.50" clamp.

INSTALLATION INSTRUCTIONS



Step 5. Once a final position has been chosen for the new exhaust system, evenly tighten all clamps from front to rear using the torque specifications on page one of the instructions. Inspect all fasteners after 25-50 miles of operation and re-tighten if necessary.