



INSTALLATION INSTRUCTIONS



2015 SILVERADO/SIERRA 2500HD/3500HD 6.0L | PART NO. 19026

BILL OF MATERIALS:

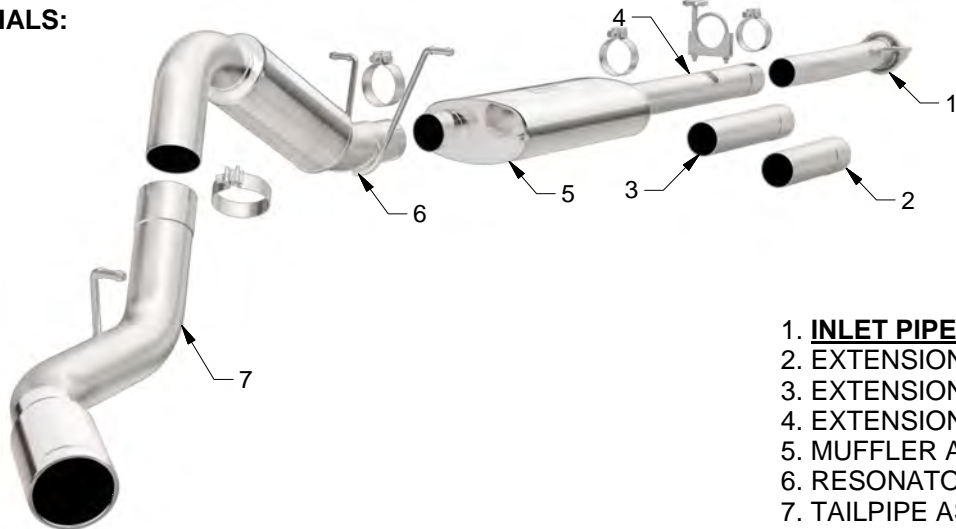

- 1. **INLET PIPE ASSEMBLY**
- 2. EXTENSION PIPE (13.0")
- 3. EXTENSION PIPE (17.0")
- 4. EXTENSION PIPE (26.5")
- 5. MUFFLER ASSEMBLY
- 6. RESONATOR PIPE ASSEMBLY
- 7. TAILPIPE ASSEMBLY



WEAR SAFETY GLASSES



READ INSTRUCTIONS THOROUGHLY BEFORE INSTALLING PRODUCT

SHOP SUPPLIES:



SPRAY LUBRICANT

To ease removal of existing exhaust components (especially on older vehicles) spray penetrating lubricant on all fasteners and hangers/insulators that will be loosened or removed and let soak before disassembly.

HARDWARE KIT:

- 1.[1] 3.50" Hanger Clamp
- 2.[3] 3.50" Clamp
- 3.[1] 4.00" Clamp

MINIMUM REQUIRED TOOLS:



15mm



Hanger Tool (Or Pry Bar)



Sawzall or other cutting device.

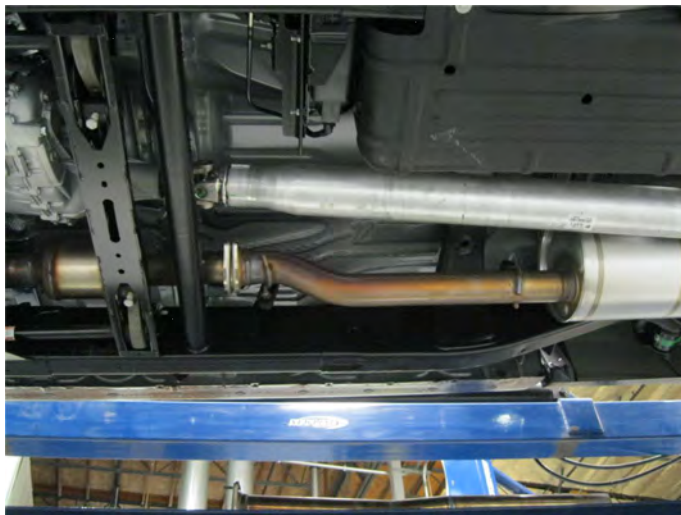
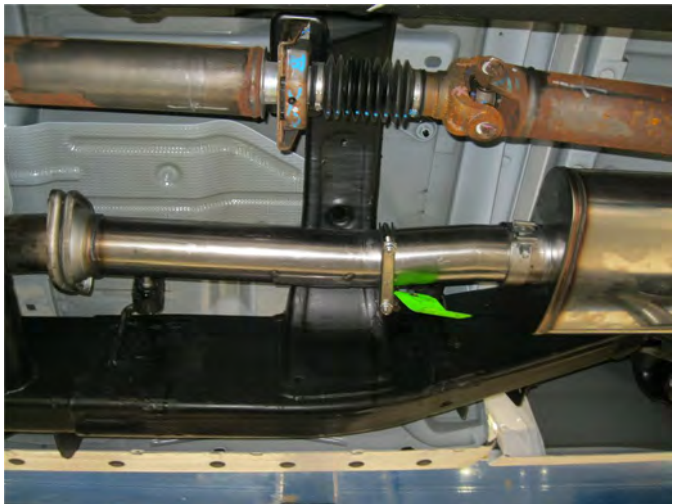

Step 1. To remove the OEM exhaust system, you will need to cut the pipe behind the muffler before it goes over the axle. Disengage the welded hangers from the rubber insulators and remove the tailpipe. Next remove the fasteners from the two bolt fange behind the catalytic converter. Do not damage or discard the fasteners or rubber insulators, as they will be re-used to mount the new system. Disengage the remainder of the hangers and remove the system.

Step 2. To begin installation of the new system fasten the Inlet Pipe Assembly to the catalytic converter using the OEM fasteners, slip the hanger clamp onto the end of the Inlet Pipe Assembly and leave loose. At this point you will need to determine what configuration your vehicle is, Extended Cab Short Bed (ECSB), Crew Cab Short Bed (CCSB), Extended Cab Long Bed (ECLB) or Crew Cab Long Bed (CCLB). On the ECSB no Extension Pipe is needed between the Inlet and Muffler Assemblies and the supplied hanger clamp is slid onto the Inlet Pipe Assembly and lined up with the hanger mount on the vehicle. This clamp/hanger is used just as a hanger while the supplied 3.50" Torca clamp fastens the pieces together. On the CCSB use the supplied 13.0" Extension Pipe. On this configuration the hanger clamp is mounted to the inlet pipe and the extra supplied Torca clamp mounts the extension pipe to the Inlet Pipe. On the ECLB use the 17.0" Extension Pipe and on the CCLB use the 26.5 extension Pipe, again using the hanger clamp to anchor the system to the existing rubber insulator and the supplied 3.50" Torca clamp the attach the pipes (Leave all clamps and fasteners loose for final adjustment of the complete system.)



INSTALLATION INSTRUCTIONS

Step 3. Install the Muffler to the Inlet Pipe Assembly/Extension Pipe using the supplied 3.50" clamp.

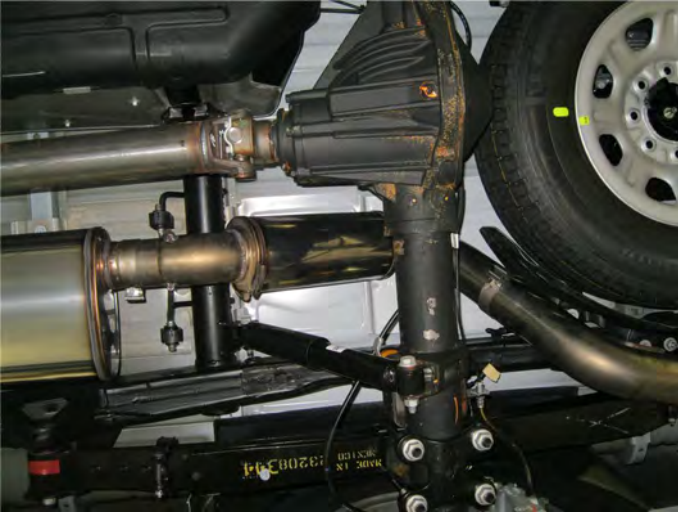

Step 3. Next install the over axle Resonator assembly to the Muffler in the similar fashion using the supplied 3.50" clamp, fitting the welded hangers into the rubber insulators.



Step 4. Finish by installing the Tail Pipe Assembly to the over axle Resonator assembly using the supplied 4.00" clamp, fitting the welded hanger into the rubber insulator.

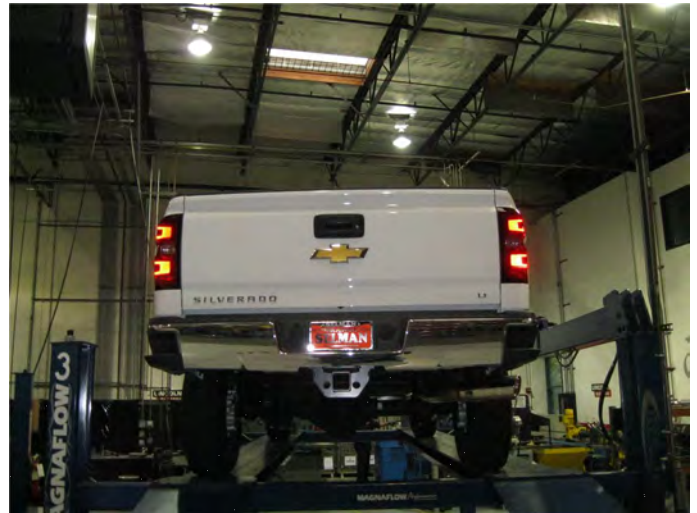

Step 5. Once a final position has been chosen for the new exhaust system, evenly tighten all clamps from front to rear using the torque specifications on page one of the instructions. Inspect all fasteners after 25-50 miles of operation and re-tighten if necessary.