



INSTALLATION INSTRUCTIONS



2015 AUDI ALLROAD 2.0L

PART NO. 15369

BILL OF MATERIALS:

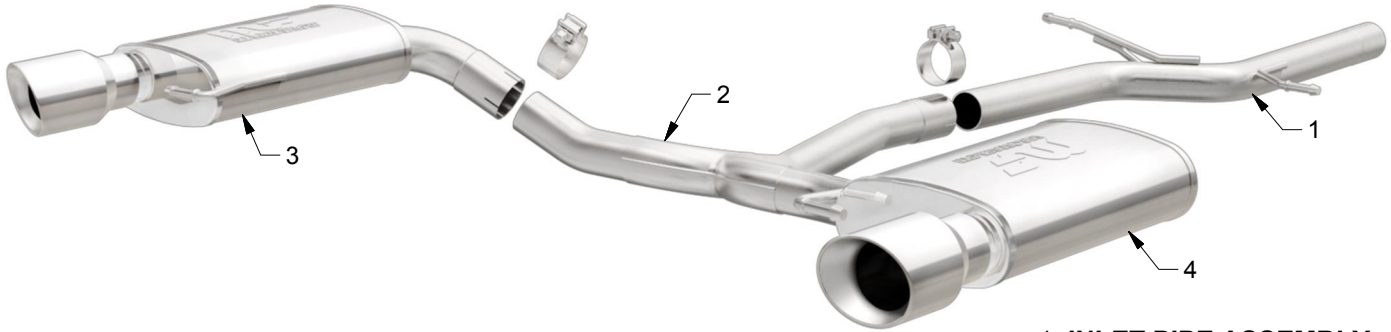

- 1. INLET PIPE ASSEMBLY
- 2. Y-PIPE ASSEMBLY
- 3. MUFFLER ASSEMBLY D/S
- 4. MUFFLER ASSEMBLY P/S



WEAR SAFETY
GLASSES



READ INSTRUCTIONS
THOROUGHLY BEFORE
INSTALLING PRODUCT

SHOP SUPPLIES:



SPRAY LUBRICANT

To ease removal of existing exhaust components (especially on older vehicles) spray penetrating lubricant on all fasteners and hangers/insulators that will be loosened or removed and let soak before disassembly.

HARDWARE KIT:

- 1.[3] 2.50" Clamp

MINIMUM REQUIRED TOOLS:



15mm
13mm



Hanger Tool
(Or Pry Bar)

INSTALLATION INSTRUCTIONS

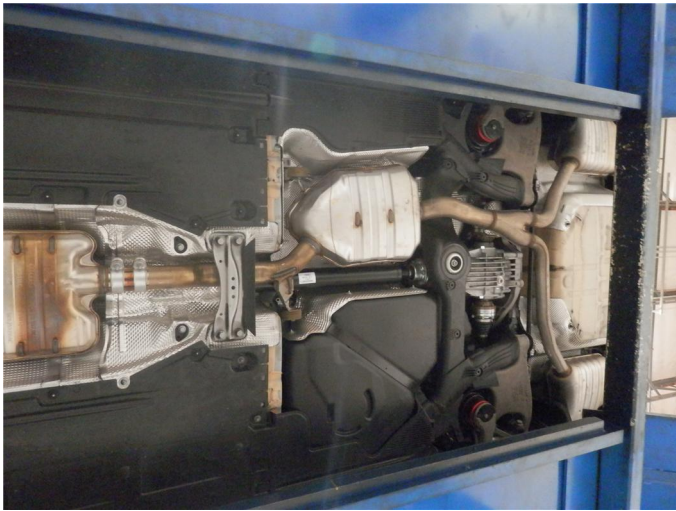

Step 1. To remove the OEM exhaust system you will first need to loosen the clamp assembly just behind the vehicles front resonator. Working front to rear disengage all hangers from the rubber insulators. The OEM system may now be removed in one piece. Retain all mounting hardware and rubber insulators as they will be needed to mount your new system.

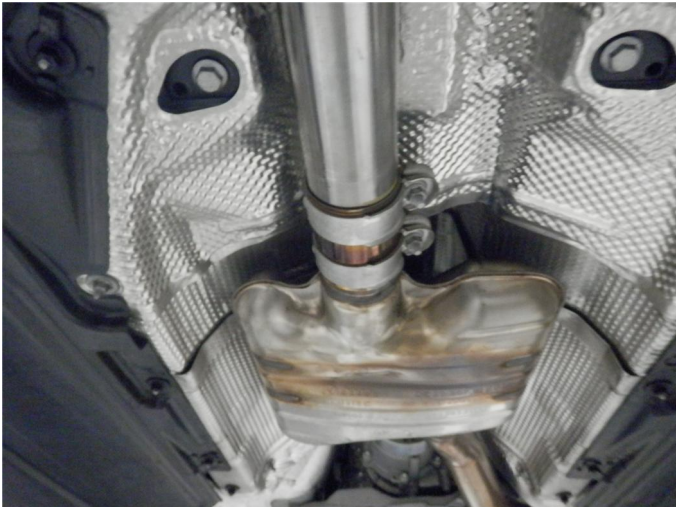

Step 2. Install your new MAGNAFLOW system by inserting the inlet end of the Inlet Pipe Assembly into the loosened OEM clamp. Locate the welded hangers to the rubber insulators. Keep all clamps loose for final adjustment of the system.

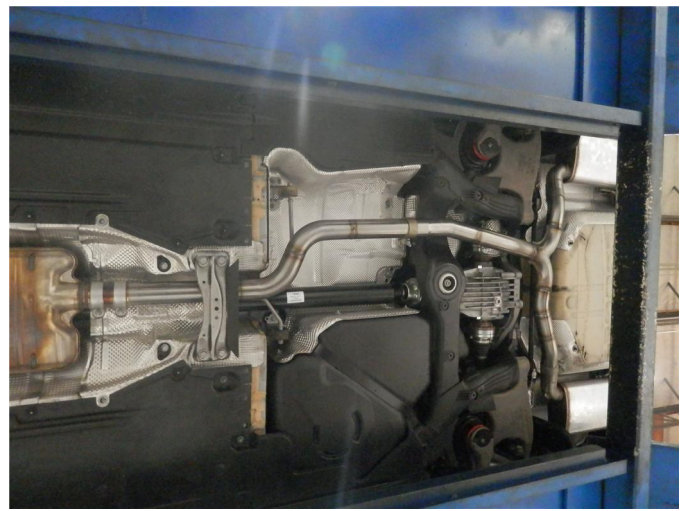

Step 3. Next loosely attach the inlet of the Y-Pipe Assembly to the outlet of the Inlet Pipe Assembly using the supplied clamp.



Step 4. Loosely install the Muffler Assemblies using the supplied clamps. Locate both welded hangers to the OEM rubber insulators.

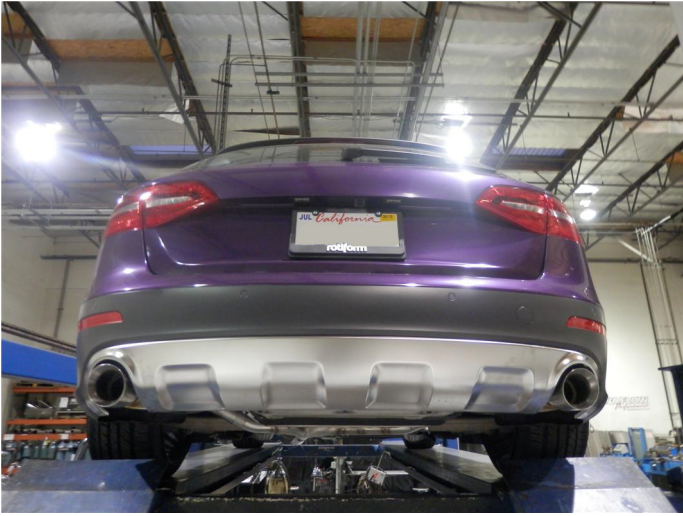

Step 5. Once a final position has been chosen for the new exhaust system, evenly tighten all clamps from front to rear using the torque specifications on page one of the instructions. Inspect all fasteners after 25-50 miles of operation and re-tighten if necessary.