



INSTALLATION INSTRUCTIONS



2015 AUDI A3 QUATTRO 2.0L T | PART NO. 15352

BILL OF MATERIALS:

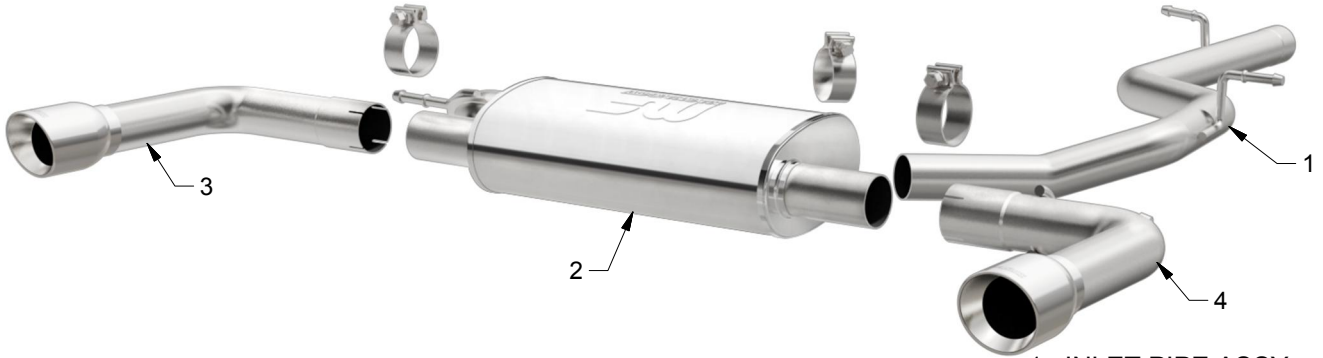

1. INLET PIPE ASSY.
2. MUFFLER ASSY
3. D/S TAIL PIPE ASSY
4. P/S TAIL PIPE ASSY



WEAR SAFETY GLASSES



READ INSTRUCTIONS THOROUGHLY BEFORE INSTALLING PRODUCT

SHOP SUPPLIES:



SPRAY LUBRICANT

To ease removal of existing exhaust components (especially on older vehicles) spray penetrating lubricant on all fasteners and hangers/insulators that will be loosened or removed and let soak before disassembly.

HARDWARE KIT:

1. [3] 2.50" Clamp

MINIMUM REQUIRED TOOLS:



15mm
13mm



Hanger Tool
(Or Pry Bar)

MAGNAFLOW RECOMMENDS PROFESSIONAL INSTALLATION ON ALL THEIR PRODUCTS



WARNING: When working on, under, or around any vehicle exercise caution. Please allow the vehicle's exhaust system to cool before removal, as exhaust system temperatures may cause severe burns. If working without a lift always consult vehicle manual for correct lifting specifications. Always wear safety glasses and ensure a safe work area. Serious injury or death could occur if safety measures are not followed.

ATTENTION: Always install any supplied band or U-bolt clamps to the proper torque specifications of 40-45 ft-lbs for band clamps and 30-35 ft-lbs for U-bolt clamps. Over tightening will result in the clamp breaking and will NOT be warranted by MagnaFlow.

INSTALLATION INSTRUCTIONS

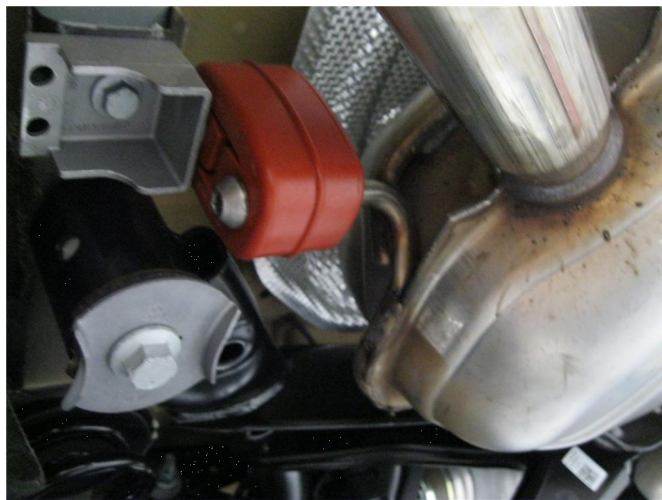
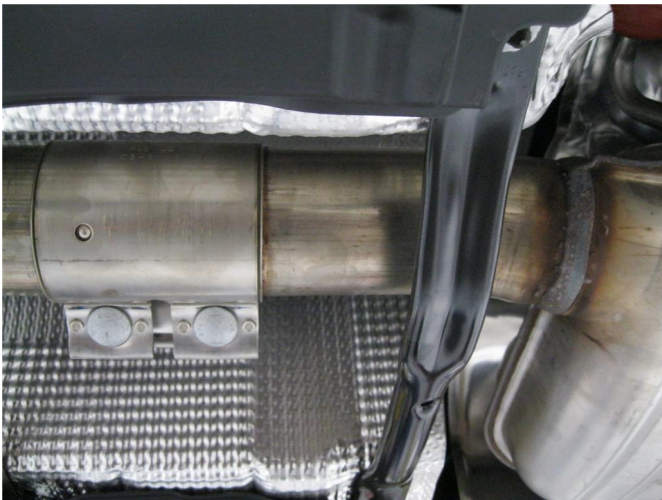

Step 1. Begin removal of the OEM system by loosening at the inlet of the Resonator and removing the black tubular cross brace. You can then disengage the welded hangers from the rubber insulators, working rearward finish removing the system. Do not damage or discard the rubber insulators or OEM clamp as they will be re-used to mount the new system.



Step 2. Begin installation of the new system by attaching the Inlet Pipe Assembly to the factory outlet using the OEM clamp and fit the hangers into the rubber insulators. Leave all clamps loose until final adjustment.



Step 3. Next Install the Muffer Assembly using the supplied 2.50" clamp and fit the welded hanger into the rubber insulator.



Step 4. Complete the installation by fastening the Driver and Passenger side Tailpipe Assemblies to the Muffer Assembly with the supplied 2.50" clamps and fit the hangers into the insulators. Re-install the factory brace.

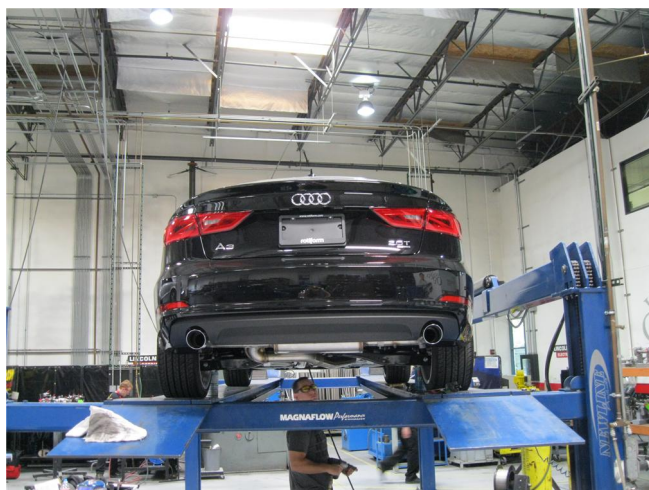

Step 5. Once a final position has been chosen for the new exhaust system, evenly tighten all clamps from front to rear using the torque specifications on page one of the instructions. Inspect all fasteners after 25-50 miles of operation and re-tighten if necessary.