



# INSTALLATION INSTRUCTIONS



2005 - 2007 Audi A4 Quattro 3.2L

PART NO. 15326

## BILL OF MATERIALS:

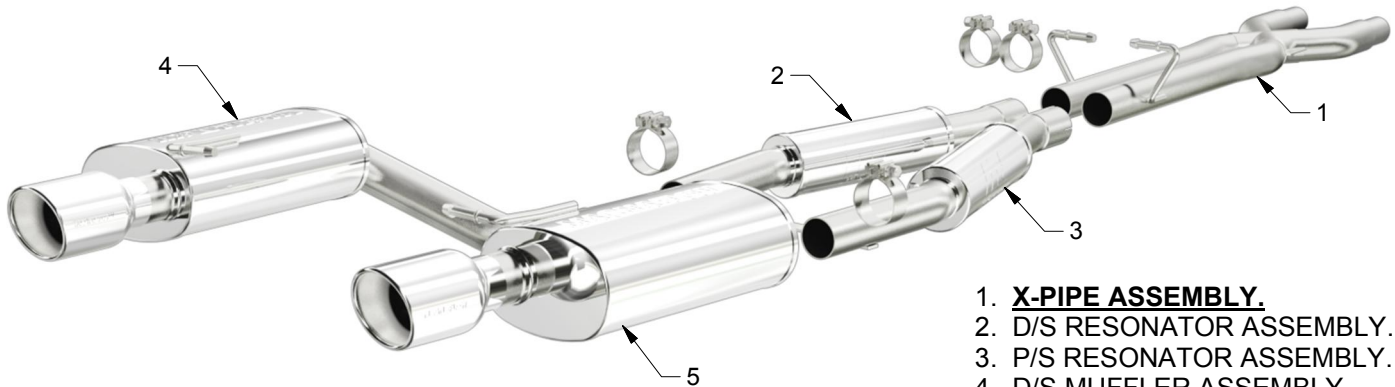

1. **X-PIPE ASSEMBLY.**
2. **D/S RESONATOR ASSEMBLY.**
3. **P/S RESONATOR ASSEMBLY.**
4. **D/S MUFFLER ASSEMBLY.**
5. **P/S MUFFLER ASSEMBLY.**



WEAR SAFETY  
GLASSES



READ INSTRUCTIONS  
THOROUGHLY BEFORE  
INSTALLING PRODUCT



SPRAY LUBRICANT

To ease removal of existing exhaust components (especially on older vehicles) spray penetrating lubricant on all fasteners and hangers/insulators that will be loosened or removed and let soak before disassembly.

## HARDWARE KIT:

1. [4] 2.50" Clamp
2. [2] 3/8" Bolt
3. [2] 3/8" Nut

## MINIMUM REQUIRED TOOLS:



15mm



Hanger Tool  
(Or Pry Bar)

## INSTALLATION INSTRUCTIONS



**Step 1.** Begin removal of the OEM system by loosening the two clamps attaching the inlet pipes to the catalytic converters. Working front to rear remove all mounting hardware and detach the welded hangers from the rubber insulators. Do not damage or discard the rubber insulators or fasteners, as they will be reused to mount your new MAGNAFLOW system.

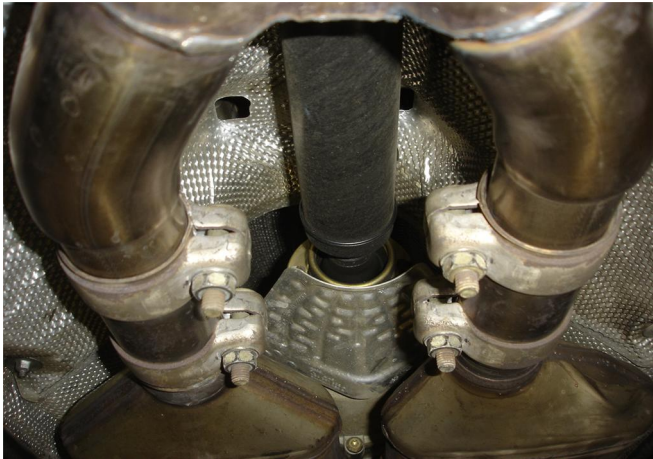

**Step 2.** Begin installation of your new exhaust system by inserting the inlet pipes of the X-Pipe Assembly into the two clamps at the catalytic converters locate the two welded hangers in the rubber insulators (leave all clamps loose for final adjustment of the complete system).

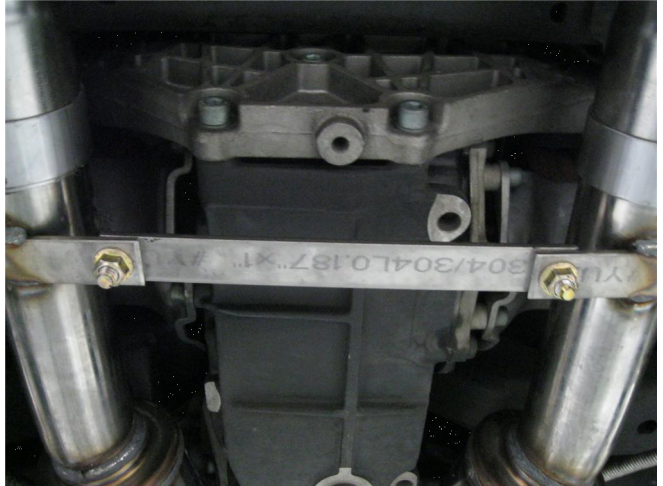

**Step 3.** Next Install the two Resonator and Muffler Assemblies in a similar fashion using the supplied 2.50" clamps and by fitting the welded hangers into the rubber insulators. Attach the supplied cross brace using the included hardware.

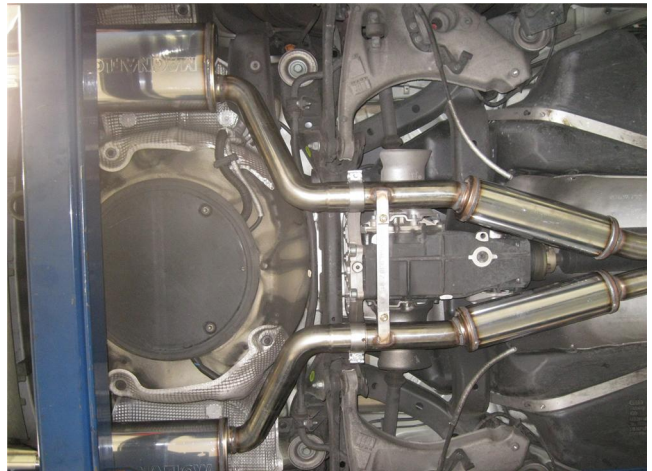

**Step 4.** Once a final position has been chosen for the new exhaust system, evenly tighten all clamps from front to rear using the torque specifications on page one of the instructions. Inspect all fasteners after 25-50 miles of operation and re-tighten if necessary.

