

2014 Toyota Tundra 4.6/5.7L

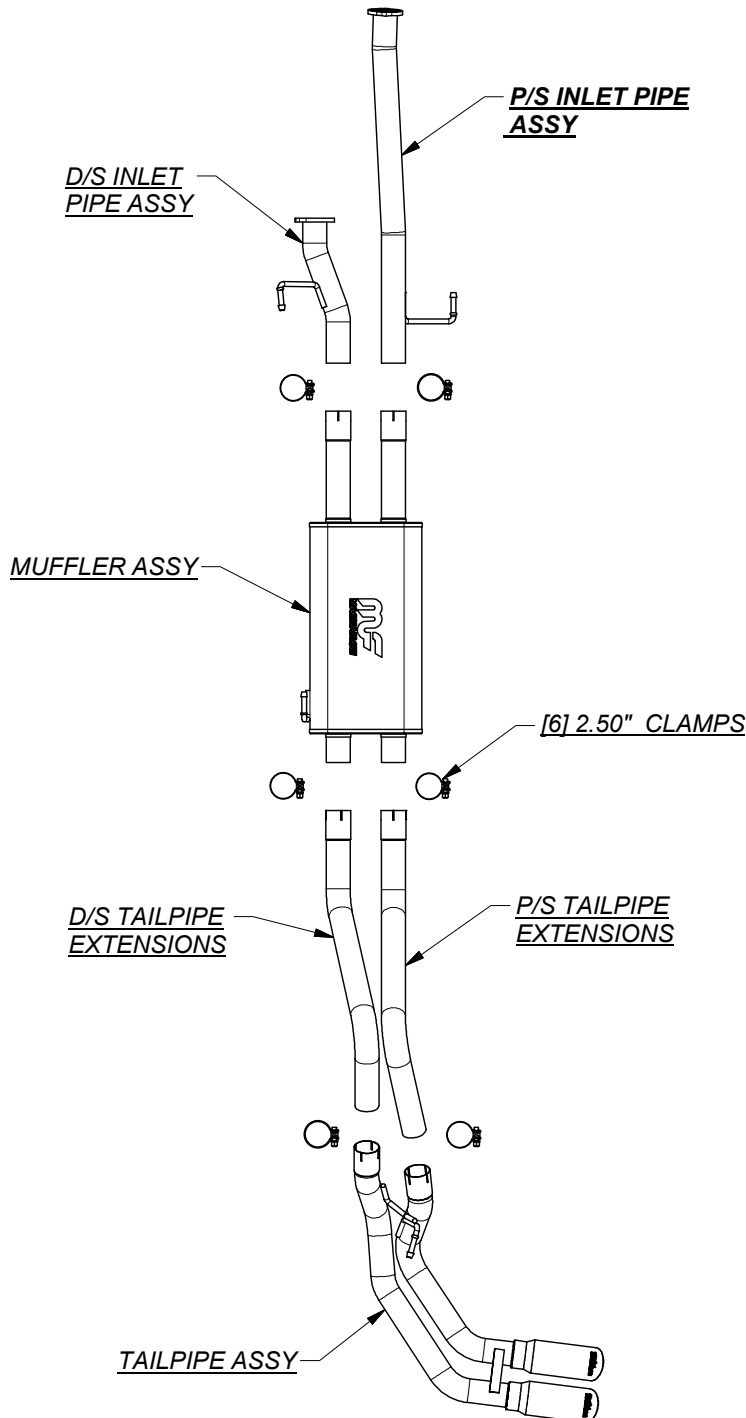

Warning: When working on, under, or around any vehicle exercise caution. Please allow the vehicle's exhaust system to cool before removal, as exhaust system temperatures may cause severe burns. If working without a lift, always consult vehicle manual for correct lifting specifications. Always wear safety glasses and ensure a safe work area. Serious injury or death could occur if safety measures are not followed.

Step 1: (Carefully read all instructions before installation) Begin by unfastening the V-band clamp attaching the tailpipe to the muffler, then unbolt the muffler inlet pipes at the 2-bolt flanges. Do not discard or damage the OEM fasteners or rubber insulators as they will be reused to mount your new Magnaflow system. Disengage the welded hangers from the rubber insulators and remove the muffler and tailpipe.

Step 2: Install the new inlet pipes reusing the OEM fasteners, and by fitting the welded hangers into the rubber insulators. Leave all clamps and fasteners loose for final adjustment of the complete system. Install the new muffler by fastening the inlets to the inlet pipes using the supplied 2.50" clamps and by fitting the hanger into the rubber insulator. Install the tailpipe extensions and tailpipe assembly in a similar fashion using the supplied 2.50" clamps.

Step 3: With all components mounted loosely, adjust the system for overall aesthetics and clearance of frame & bodywork. (MAGNAFLOW recommends at least 1/2" of clearance between the exhaust system and any body panels to prevent heat-related body damage or fire.)

Step 4: Once a final position has been chosen for the new system, evenly tighten all fasteners from front to rear. The supplied band clamps must be VERY tight to properly align the pipes and prevent leaks (Approximately 40ft-lbs). U-bolt clamps should be tightened to approximately 30-35ft-lbs. Inspect all fasteners after 25-50 miles of operation and retighten if necessary.