



# INSTALLATION INSTRUCTIONS



'09 - '14 DODGE RAM 1500 3.6L

PART NO. 15250

## BILL OF MATERIALS:

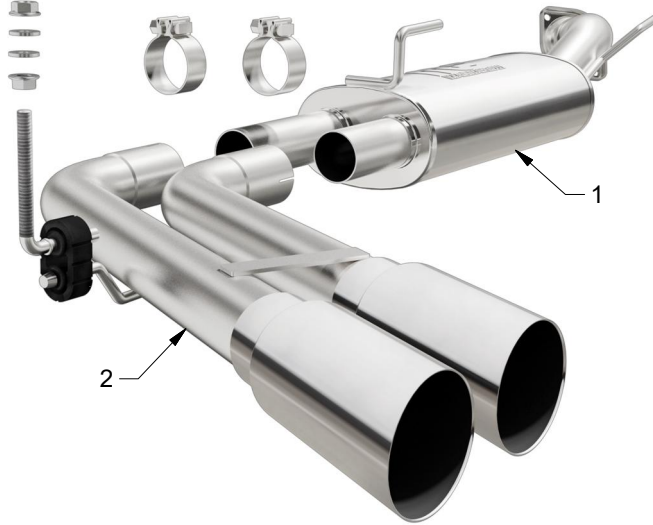

- 1. MUFFLER ASSEMBLY
- 2. TAIL PIPE ASSEMBLY



WEAR SAFETY GLASSES



READ INSTRUCTIONS THOROUGHLY BEFORE INSTALLING PRODUCT

## SHOP SUPPLIES:



SPRAY LUBRICANT

To ease removal of existing exhaust components (especially on older vehicles) spray penetrating lubricant on all fasteners and hangers/insulators that will be loosened or removed and let soak before disassembly.

## HARDWARE KIT:

- 1. [2] 2.50" CLAMP
- 2. [1] RUBBER ISOLATOR
- 3. [1] THREADED HANGER
- 4. [2] 7/16" FLANGE NUT
- 5. [2] 7/16" FLAT WASHER

## MINIMUM REQUIRED TOOLS:



15mm



Hanger Tool (Or Pry Bar)

## MAGNAFLOW RECOMMENDS PROFESSIONAL INSTALLATION ON ALL THEIR PRODUCTS



**WARNING:** When working on, under, or around any vehicle exercise caution. Please allow the vehicle's exhaust system to cool before removal, as exhaust system temperatures may cause severe burns. If working without a lift always consult vehicle manual for correct lifting specifications. Always wear safety glasses and ensure a safe work area. Serious injury or death could occur if safety measures are not followed.

**ATTENTION:** Always install any supplied band or U-bolt clamps to the proper torque specifications of 40-45 ft-lbs for band clamps and 30-35 ft-lbs for U-bolt clamps. Over tightening will result in the clamp breaking and will NOT be warranted by MagnaFlow.

## INSTALLATION INSTRUCTIONS

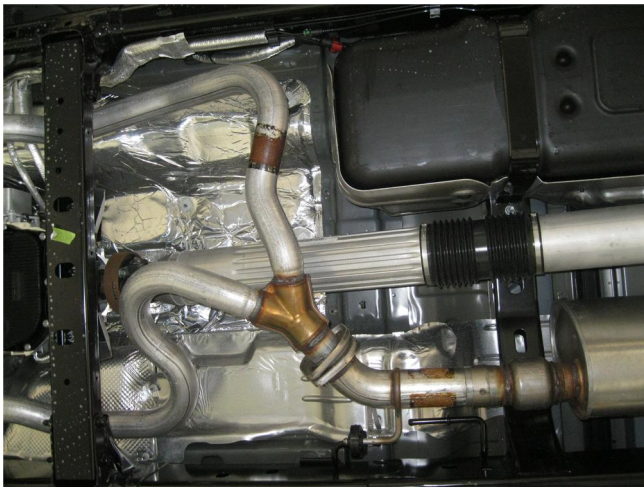

**Step 1.** To remove the OEM exhaust system, you will first need to unbolt the muffler assembly from the Y-Pipe assembly.



**Step 2.** Unbolt the clamp just behind the muffler. Do not damage or discard the OEM fasteners or rubber insulators, as they will be reused to mount the new system. Disengage all hangers and remove the OEM system from the vehicle.

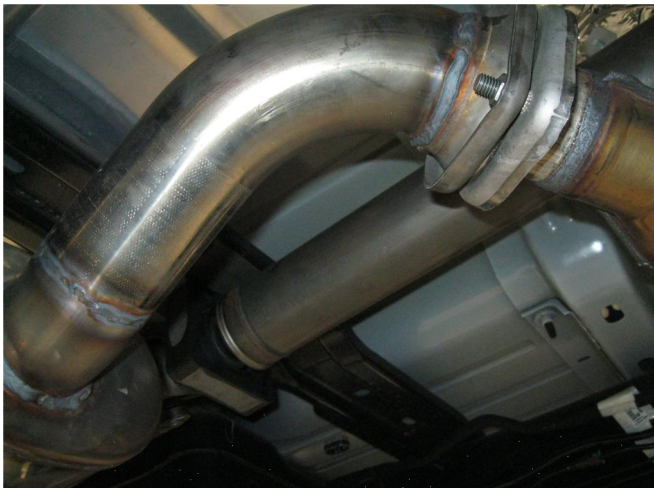

**Step 3.** You are now ready to install your new MAGNAFLOW exhaust system. Begin by bolting the inlet flange of the Muffler Assembly to the Y-Pipe assembly using the OEM hardware. Engage both welded hangers to the rubber isolators.



**Step 4.** To support the Tail Pipe Assembly you will need to locate the supplied threaded hanger through two existing holes in the vehicles sub frame. Secure with the supplied hardware as shown.



**Step 5.** Next, install the Tail Pipe Assembly by slipping the inlets over the Muffler Assembly outlet pipes. Loosely secure with the supplied clamps. Locate the supplied rubber isolator to the previously mounted hanger and the welded hanger on the assembly.



**Step 6.** Once a final position has been chosen for the new exhaust system, evenly tighten all clamps from front to rear using the torque specifications on page one of the instructions. Inspect all fasteners after 25-50 miles of operation and re-tighten if necessary.