



# INSTALLATION INSTRUCTIONS



'13-'15 LINCOLN MKZ 2.0L TURBO | PART NO. 15230

## BILL OF MATERIALS:

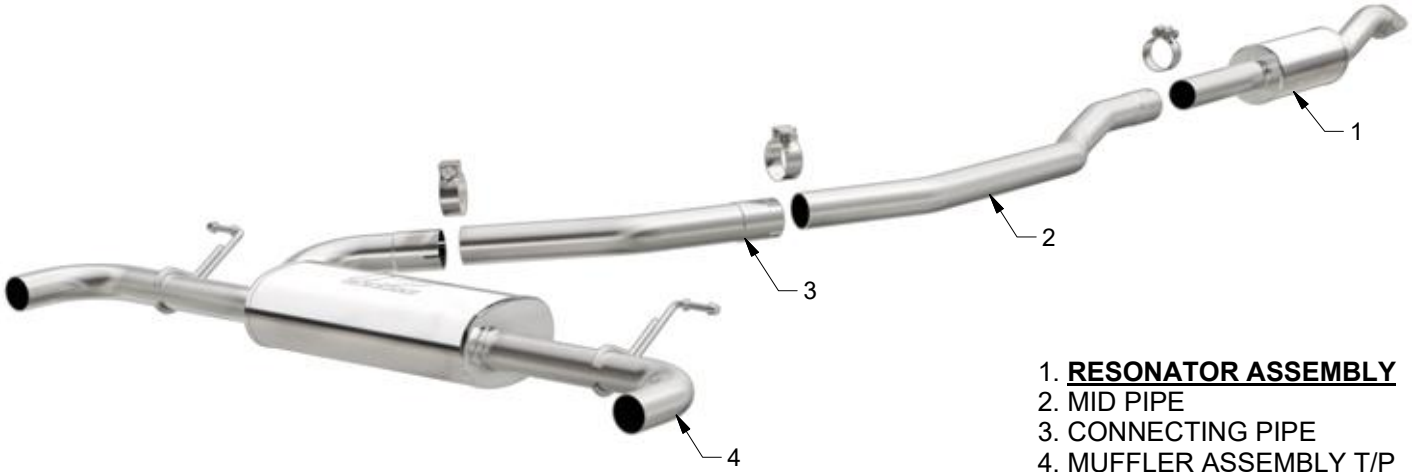

1. **RESONATOR ASSEMBLY**
2. **MID PIPE**
3. **CONNECTING PIPE**
4. **MUFFLER ASSEMBLY T/P**



WEAR SAFETY  
GLASSES



READ INSTRUCTIONS  
THOROUGHLY BEFORE  
INSTALLING PRODUCT



SPRAY LUBRICANT

To ease removal of existing exhaust components (especially on older vehicles) spray penetrating lubricant on all fasteners and hangers/insulators that will be loosened or removed and let soak before disassembly.

**HARDWARE KIT:**  
1.[3] 2.50" Clamp

## MINIMUM REQUIRED TOOLS:



15mm  
13mm



Hanger Tool  
(Or Pry Bar)

## INSTALLATION INSTRUCTIONS



**Step 1.** Begin removing the OEM exhaust system by unbolting the flange at the catalytic converter outlet. Retain the mounting hardware as it will be needed to install your new system.



**Step 3.** Begin installing your new system by loosely attaching the inlet flange of the Resonator Assembly to the catalytic converter outlet using the OEM fasteners.



**Step 2.** Disengage the welded hangers from the rubber insulators on the muffler assembly. Again, retain all mounting hardware as it will be needed to mount your new system. The OEM exhaust may now be removed in one piece.



**Step 4.** Loosely install the Mid Pipe to the Resonator Assembly and Connecting Pipe using the supplied 2.50" clamps.

## INSTALLATION INSTRUCTIONS



**Step 5.** Next install the Muffler Tail Pipe Assembly by attaching it to the Connecting Pipe with the supplied clamp and engaging all welded hangers to the rubber insulators. Locate both tail pipes to the OEM exhaust tip shrouds.



**Step 6.** Once a final position has been chosen for the new exhaust system, evenly tighten all clamps from front to rear using the torque specifications on page one of the instructions. Inspect all fasteners after 25-50 miles of operation and re-tighten if necessary.