



## MAXX-G Rear Anti Roll Bar

2011-2016 R60 Countryman & R61 Pacemen

Part # 60-520119, 60-520222, 60-520325

### Installation Guide

*M7 Speed engineers and manufactures the highest quality MINI accessories and performance parts available anywhere on the planet! Please inspect your parts when you receive them to verify everything is included and no damage has happened during shipment. Read these instructions completely BEFORE attempting to install this product.*

**This installation is classified as a MODERATE to HIGH skill level task.**



#### CAUTION:

**WHEN WORKING UNDER YOUR CAR ALWAYS USE THE RIGHT EQUIPMENT FOR THE JOB. DON'T BE TEMPTED TO TAKE SHORT CUTS OR USE INAPPROPRIATE ITEMS. NEVER WORK UNDERNEATH A VEHICLE THAT IS ONLY SUPPORTED BY A JACK; USE AXLE STANDS OR CAR RAMPS THAT ARE IN GOOD CONDITION AND PROPERLY RATED FOR YOUR VEHICLE'S WEIGHT.**

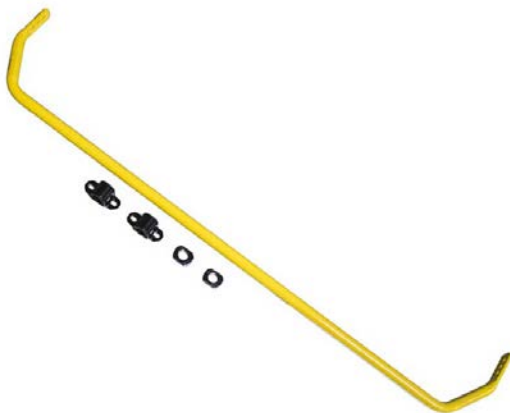

Figure 2: MAXX-G RARB w/Bushings



Figure 1: Supplied Hardware Kit

INSTALLATION OUTLINE:

1. Remove the factory rear anti-roll bar (RARB) per manufacturer's instructions.
  - a. [note: this entails lowering the rear cross member a minimum of 2"]
2. Place new MAXX-G rear anti-roll bar into its approximate operational location.
3. Remount rear cross member and associated parts per manufacturer's instructions. Do not connect RARB links or mounting bushings at this time.
4. On each side place one supplied black urethane bushing and u-bracket around the antiroll bar at its approximate mounting location.
5. Place the supplied split locking collars around antiroll bar at the inside of each bushing.
  - a. Thread bolts into collar. Do not tighten.
6. Roughly center the antiroll bar with the center of the car.
7. Once the bar is centered coat the inside of the bushing & outside of the antiroll bar interface (where the bar and bushing will run together) with a liberal amount of the supplied white silicone grease.

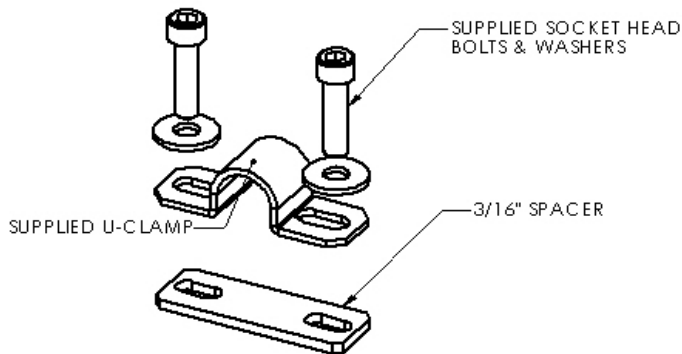

8. Place one 3/16" spacer between antiroll bar u-bracket and vehicle's frame mounting point.

9. Install supplied bolts and washers and torque the u-clamps to 30-ft-lbs (41 n-m)

**Figure 3: RARB Clamp Assembly**

**FINALIZE REAR ANTI-ROLL BAR LOCATION**

10. Using a straight edge measure from the outside face of each brake rotor to the flat face of each end link adjusting point on the rear anti-roll bar.
11. Position the rear ant-roll bar so the left side and right side measurements are within 1/16" of each other. [approximately 3 1/8"]
12. Slide locking collars so they contact the inside edge of each left hand and right hand urethane bushing.
13. Tighten the split collar screws to hold the antiroll bar from sliding off center.
14. Connect links to the anti-roll bar and tighten to specifications.
15. Finalize the installation by reversing the disassembly process from this point
16. Safety check each bolt that was removed and installed for proper tightness.



Measure from outside face of rear brake rotor to this face each side