



## INSTALLATION INSTRUCTIONS FOR MOUNTING

### FRONT PARKING SENSOR RELOCATION BRACKETS ON THE FOLLOWING GRILLE GUARD MODEL NOS.:

331410/331413, 341410/341413, 331440/331443, 341440/341443, 331512/331443 &  
341512/331443 ON:

2014 AND NEWER 1500 CHEVROLET SILVERADO/GMC SIERRA  
2015 AND NEWER 2500HD/3500 CHEVROLET SILVERADO/GMC SIERRA

THIS KIT CONTAINS MOUNTING BRACKETS, WIRING HARNESES AND ALL REQUIRED HARDWARE TO RELOCATE THE MIDDLE TWO PARKING SENSORS IN THE FRONT BUMPER ON CHEVROLET & GMC PICKUPS TO A POSITION ON THE GRILLE GUARD UPRIGHT SO THAT THE UPRIGHTS DO NOT INTERFERE WITH THE OPERATION OF THE SENSORS.

1. READ THE INSTRUCTIONS COMPLETELY AND CHECK TO MAKE SURE THAT ALL OF THE REQUIRED PARTS ARE ON HAND BEFORE STARTING THE INSTALLATION. THE CARTON SHOULD CONTAIN:

- (1) LH SENSOR MOUNTING BRACKET
- (1) RH SENSOR MOUNTING BRACKET
- (1) LH MOUNTING BRACKET COVER
- (1) RH MOUNTING BRACKET COVER
- (1) WIRING PACKAGE
- (1) CUSTOMER SERVICE PACKAGE

#### **REFER TO *fig. 1* FOR SENSOR BRACKET ASSEMBLY INSTRUCTIONS 2-14**

2. REMOVE THE FRONT BUMPER. (SEE SHEET 4 & 5 OF 5) (CHECK FIRST IF YOU CAN REMOVE THE SENSORS WITHOUT REMOVING THE BUMPER.)
3. LOCATE THE TWO CENTER FRONT SENSOR WIRE CONNECTORS AND DISCONNECT THEM FROM THE SENSORS. CAREFULLY REMOVE THE SENSORS FROM THEIR BRACKETS. REMOVE THE BRACKETS FROM THE FRONT BUMPER ON THE GMC. THE CHEVROLET SENSOR BRACKET IS NOT REMOVEABLE.
4. INSERT THE MALE ENDS OF THE SENSOR RELOCATION WIRE HARNESES (ITEM #11) THROUGH THE SENSOR HOLES IN THE FACE OF THE BUMPER AND PLUG THEM INTO THE FACTORY WIRE HARNESS THAT WAS DISCONNECTED FROM THE PARKING SENSORS. INSTALL THE APPROPRIATE GROMMETS (ITEM #6 GMC OR #7 CHEVROLET) IN THE HOLES IN THE BUMPERS AROUND THE WIRE HARNESES.
5. REINSTALL THE BUMPER AND MOUNT THE GRILLE GUARD, LEAVING OUT THE TOP BOLT THAT HOLDS THE UPRIGHTS TO THE MOUNTING BRACKETS.
6. INSTALL THE GM SENSOR BRACKETS (ITEM #5) INTO THE SENSOR BRACKET COVERS (ITEMS #3 & #4) AND SNAP INTO PLACE.



REVISED 26FEB15 LVL B  
REVISED 16FEB15 LVL A  
202821 SHEET 1 OF 5 01DEC14

**(NOTE: BEFORE MOUNTING THE BRACKETS TO THE UPRIGHTS, INSTALL THE 1/4"-20 SINGLE THREAD J-NUTS (ITEM #10) ON TO THE TABS OF THE MOUNTING BRACKETS (ITEMS #1 & #2.)**

7. INSERT THE CARRIAGE BOLTS (ITEM #8) INTO THE SQUARE HOLES IN THE SENSOR MOUNTING BRACKETS (ITEMS #1 & #2).
8. MOUNT THE BRACKETS (ITEMS #1 & #2) TO THE TOP HOLES IN THE UPRIGHTS SO THAT THE SENSOR BRACKETS (ITEMS #1 & #2) ARE TO THE INSIDE OF THE UPRIGHTS. INSTALL THE FLAT WASHERS AND ACORN NUTS BUT LEAVE LOOSE AT THIS TIME.
9. FEED THE CONNECTOR END OF THE WIRE HARNESSSES THROUGH THE HOLES IN THE BACK OF THE BRACKETS (ITEMS #1 & #2). INSTALL THE GROMMETS AROUND THE WIRING.
10. PLUG THE SENSORS INTO THE CONNECTORS ON THE WIRE HARNESSSES.
11. INSTALL THE SENSORS INTO THE GM SENSOR MOUNTING BRACKETS (ITEM #5) AND PLACE THE MOUNTING BRACKET COVERS (ITEMS #3 & #4) ON TO THE MOUNTING BRACKETS (ITEMS #1 & #2).
12. INSTALL THE 1/4"-20 X 5/8" BUTTON HEAD SCREWS (ITEM #9) INTO THE OUTSIDE THE OF THE COVERS (ITEMS #3 & #4).
13. ADJUST THE MOUNTING BRACKETS (ITEMS #1 & #2) SO THAT THE FACE OF THE COVERS (ITEM #3 & #4) ARE STRAIGHT UP AND DOWN. TIGHTEN ACORN NUTS ON THE CARRIAGE BOLTS (ITEM #8) .
14. INSERT EXCESS WIRE INTO THE BUMPER.

**SERVICE PARTS LIST**

ITEM	PART NO.	QTY	DESCRIPTION
1	202815	1	SENSOR MOUNTING BRACKET – LH
2	202816	1	SENSOR MOUNTING BRACKET – RH
3	202817	1	MOUNTING BRACKET COVER – LH
4	202818	1	MOUNTING BRACKET COVER – RH
5	109853	2	MOUNTING BRACKET SENSOR– 22947030,GM
6	109855	4	GROMMET – 2290-1-A60
7	109860	2	GROMMET – 7/8" X 3/8" X 3/8",32829210
8	109724	2	ROUND HEAD BOLT – 1/2"-13 X 3-1/4", SST
9	109861	2	BUTTON HEAD SCREW – 1/4"-20 X 5/8", SST, BZP
10	109862	2	U-NUTS – 1/4"-20 SINGLE THREAD
11	109854	2	SENSOR RELOCATION WIRE HARNESS



SERVICE PARTS LIST

MODEL NO. - 390200

fig.1

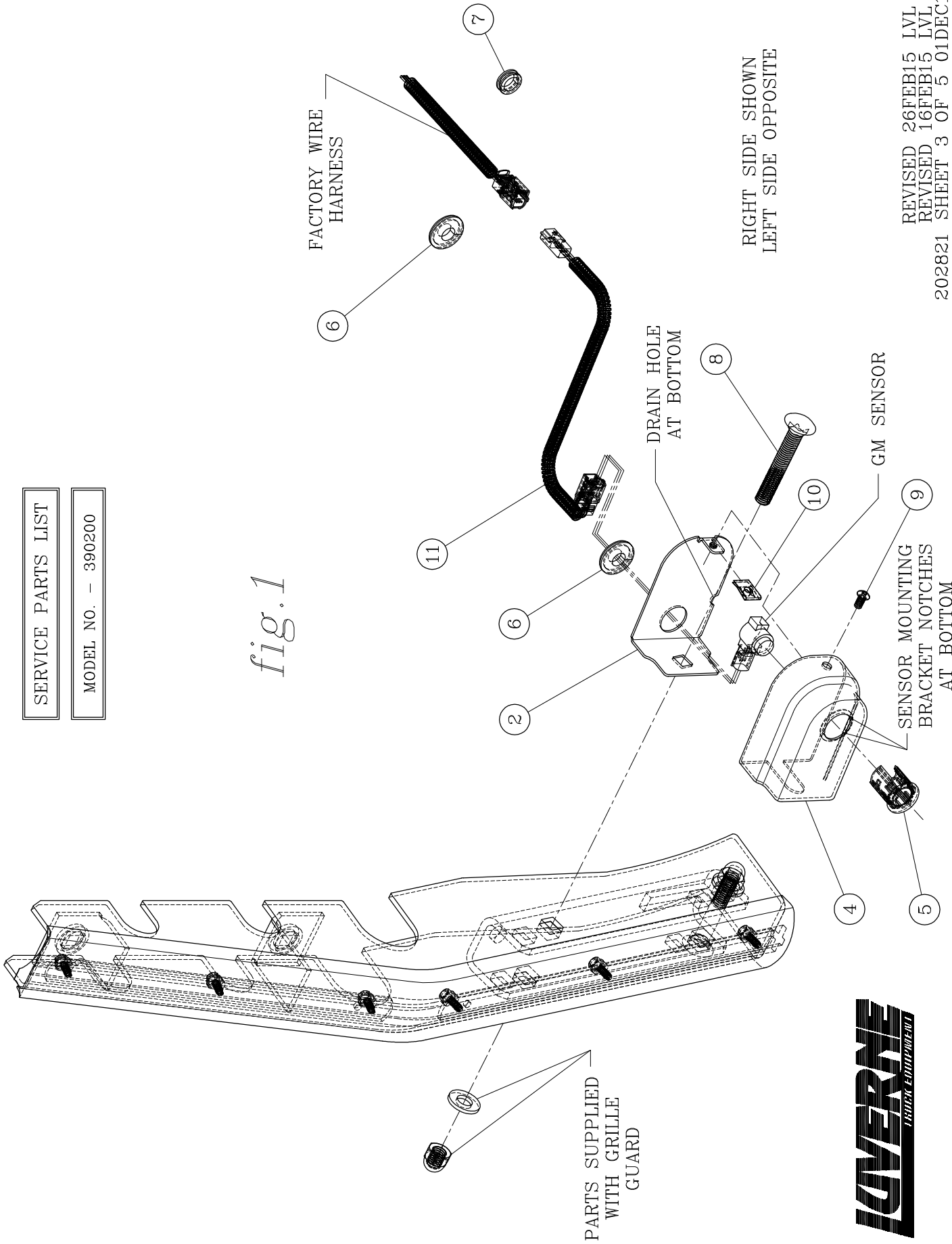

RIGHT SIDE SHOWN  
LEFT SIDE OPPOSITE



REVISED 26FEB15 LVL B  
REVISED 16FEB15 LVL A  
202821 SHEET 3 OF 5 01DEC14

## BUMPER REMOVAL 2500HD/3500

### REMOVE THE FACTORY FRONT BUMPER ASSEMBLY:

1. UNPLUG THE WIRE HARNESS SERVICING THE FRONT BUMPER.
2. ON THE TWO END BRACES BEHIND THE END OF THE BUMPER, REMOVE THE BOLTS THAT FASTEN THE TUBULAR BRACES TO THE BUMPER AND LOOSEN THE TWO BOLTS ON THE FRAME SIDE.
3. OPEN THE HOOD AND POP OUT THE TWELVE PLASTIC RIVETS AND REMOVE THE PLASTIC SHROUD COVERING THE FAN AND RADIATOR.
4. UNSCREW THE FOUR SCREWS ON THE TOP OF THE GRILLE, SECURING THE GRILLE TO THE VEHICLE.
5. PULL OUT ON THE TOP OF THE GRILLE AND REMOVE IT FROM THE VEHICLE.
6. STANDING AT THE FRONT OF THE VEHICLE, LOOKING DOWN, FIND THE FOUR BOLTS THAT FASTEN THE BUMPER TO THE TRUCK AND, REMOVE THE FOUR BOLTS.
7. REMOVE THE BUMPER ASSEMBLY.
8. REMOVE THE TOW HOOKS.



## **BUMPER REMOVAL**

**1500**

### **REMOVE THE FACTORY FRONT BUMPER ASSEMBLY:**

1. UNPLUG THE WIRE HARNESS SERVICING THE FRONT BUMPER.
2. UNDER THE VEHICLE, LOCATE THE TWO TUBULAR SIDE BRACES AND REMOVE THE BOLTS HOLDING THE BRACE TO THE BUMPER AND THEN THE OUTER BOLT HOLDING THE BRACE TO THE FRAME. THE BRACE SHOULD BE ABLE TO BE PIVOTED TO CLEAR THE BUMPER.
3. UNCLIP AND REMOVE ONE SCREW FROM EACH SIDE OF THE LOWER PLASTIC FENDER TRIM THAT GOES OVER THE PLASTIC BUMPER TOP PANEL ENDS.
4. PULL ON THE FENDER TRIM TO RELEASE THE TWO CLIPS ON EACH SIDE. THE CLIPS SHOULD STAY IN THE TRIM, BUT IF NOT THE CLIP WILL NEED TO BE PRYED OUT OF THE FENDER AND REINSTALLED INTO THE TRIM.
5. REMOVE THE TWO SCREWS IN BOTH THE INNER FENDERS HOLDING THE PLASTIC TOP BUMPER PANEL ON.
6. OPEN THE HOOD AND POP OUT THE TWELVE PLASTIC RIVETS AND REMOVE THE PLASTIC SHROUD COVERING THE FAN AND RADIATOR.
7. PULL THE PLASTIC TOP BUMPER PANEL OUT, RELEASING THE CLIPS, THIS PANEL NEEDS TO BE REMOVED AND SET ASIDE.
8. REMOVE THE BOLTS HOLDING THE LOWER PORTION OF THE GRILLE ON, THESE WILL BE BEHIND WHERE THE PLASTIC TOP BUMPER PANEL WAS.
9. AFTER THE BOLTS ARE REMOVED, PULL OUT ON THE GRILLE, RELEASING THE CLIPS.
10. STANDING AT THE FRONT OF THE VEHICLE, LOOKING DOWN, FIND THE FOUR BOLTS THAT FASTEN THE BUMPER TO THE TRUCK (ONE ON EACH SIDE OF THE TWO FRAME RAILS AND, REMOVE THE FOUR BOLTS.
11. SET THE BUMPER ASIDE TO WORK ON THE WIRING.



REVISED 26FEB15 LVL B  
REVISED 16FEB15 LVL A  
202821 SHEET 5 OF 5 01DEC14