

INSTALLATION INSTRUCTIONS AND PARTS LIST

VEHICLE APPLICATION: MODEL 250740 (12.00" X 20.00") AND 250743 (12.00" X 23.00")
NO DRILL FRONT OR REAR RUBBER SPLASH GUARDS
2007 AND NEWER GM PICKUPS

1. READ INSTRUCTIONS COMPLETELY AND CHECK TO MAKE SURE THAT ALL REQUIRED PARTS (LISTED ON SERVICE PARTS LIST) ARE ON HAND BEFORE STARTING THE INSTALLATION.

MOUNTING 250740 OR 250743 SPLASH GUARDS ON THE FRONT: (SEE SHEET #2)

2. INSTALL THE SPLASH GUARDS AS FOLLOWS:
 - 2.1 REMOVE TWO FACTORY HEX HEAD SEMS SCREWS (THESE SCREWS ARE NOT REUSED) AND THE BOTTOM INBOARD PLASTIC PUSH IN FASTENER THAT RETAIN THE WHEEL WELL LINER TO THE WHEEL WELL FLANGE.
 - 2.2 POSITION THE SPLASH GUARD AGAINST THE WHEEL WELL FLANGE AND FASTEN AS FOLLOWS. INSTALL TWO HEX HEAD SEMS SCREWS (ITEM #8) THRU THE TOP AND SECOND HOLE DOWN FROM THE TOP IN THE SPLASH GUARD. INSTALL A 1/4 X 1-1/4" SOCKET BUTTON HEAD SCREW (ITEM #5), 1/4" FENDER WASHER (ITEM #7) AND 1/4-20 SERR FLANGE NUT (ITEM #6) THRU THE BOTTOM INBOARD HOLE AS SHOWN.
 - 2.3 LOCATE THE SPLASH GUARD IN OR OUT AS DESIRED, LEVEL THE SPLASH GUARD AND TIGHTEN THE FASTENERS.

MOUNTING 250740 OR 250743 SPLASH GUARDS ON THE REAR WITH NO DRILL CLIPS: (SEE SHEET #3)

3. TAKE THE NO DRILL CLIPS (ITEM #5) AND MULTI THREAD U-NUTS (ITEMS #6) AND A SPLASH GUARD AND ASSEMBLE AS FOLLOWS:
 - 3.1 ASSEMBLE CLIPS (ITEM #5) AND U-NUTS (ITEM #6) TOGETHER.
 - 3.2 STARTING WITH THE BOTTOM HOLE (ROUND HOLE) ASSEMBLE THE SCEW AND WASHERS THOUGH THE SPLASH GUARD AND INTO THE CLIP. DO NOT TIGHTEN ALL THE WAY.
 - 3.3 POSITION THE SPLASH GUARD AGAINST THE WHEEL WELL FLANGE AND HOOK THE CLIP BEHIND IT WITH THE SERRATED EDGE ON THE WHEEL WELL FLANGE. TIGHTEN FINGER TIGHT.
 - 3.4 INSTALL THE REMAINING CLIPS (2) THE SAME AS BEFORE, THIS TIME USING THE TWO TOP (OBLONG) HOLES AND MAKING SURE CLIPS HOOK BEHIND WHEEL WELL FLANGE. (AS IN THE PICTURE ON SHEET #3) AND FINGER TIGHTEN.
 - 3.5 LOCATE THE SPLASH GUARD IN OR OUT AS DESIRED, LEVEL THE SPLASH GUARD AND TIGHTEN THE FASTENERS.

MOUNTING 250740 OR 250743 MUDGUARDS ON REAR WITH FENDER WELL LINER: DRILL APPLICATION

1. HOLD MUDGUARD UP AND LINE HOLES UP WITH THE FENDER FLANGE SO THAT ALL 3 HOLES LINE UP ON CENTER OF FLANGE, MARK HOLES. DRILL 5/16" HOLES.
2. SLIDE U-NUT (ITEM# 6) ON EACH DRILLED HOLE, THEN PLACE MUDGUARD ON, LINING UP THE HOLES ON MUDGUARD WITH THE U-NUTS, FASTEN WITH SCREW AND WASHER (ITEMS#8 & 9).
3. LOCATE THE MUDGUARD IN OR OUT AS DESIRED, LEVEL THE MUDGUARD AND TIGHTEN THE FASTENERS.



REVISED 20OCT10 LVL B
REVISED 27JUL09 LVL A
550092 SHEET 1 OF 3 19FEB08

SERVICE PARTS LIST

2007 GM PICKUPS
 MODEL NO. - 250740 & 250743

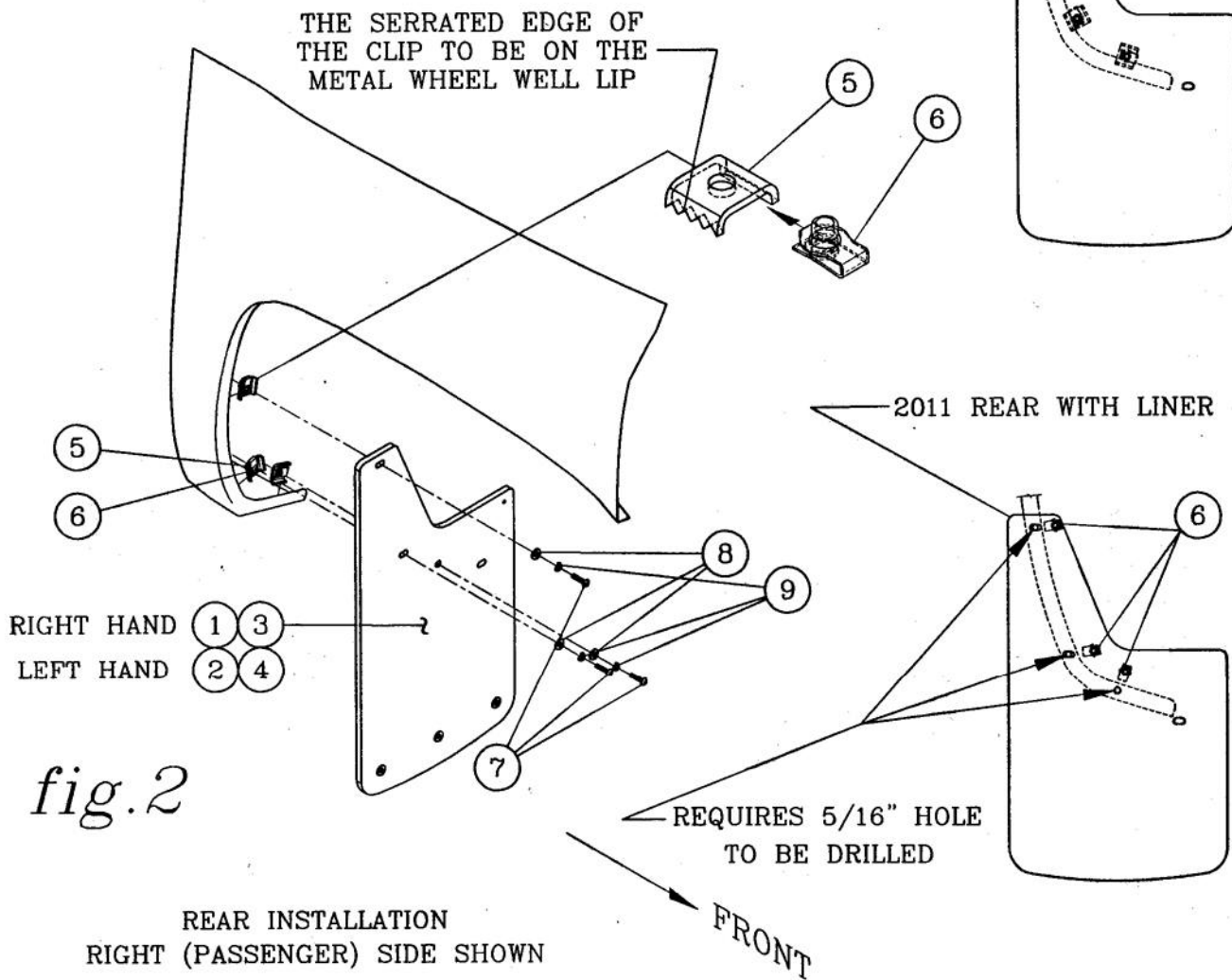

fig.2

ITEM	PART NO.	QTY	DESCRIPTION
1	550083	1	SPLASH GUARD-RUBBER,12 X 20,07,GM PICKUPS,RH
2	550084	1	SPLASH GUARD-RUBBER,12 X 20,07,GM PICKUPS,LH
3	550085	1	SPLASH GUARD-RUBBER,12 X 23,07,GM PICKUPS,RH
4	550086	1	SPLASH GUARD-RUBBER,12 X 23,07,GM PICKUPS,LH
5	550058	6	BRACKET - NO DRILL CLIP, 07 GM PICKUP
6	106604	6	MULTI THREAD U-NUT - 1/4-20
7	108053	6	SCREW - BTN HD SOC, 1/4-20 X 1-1/4", SST, BZP
8	108521	6	WASHER - FENDER, 1/4 X 1, SST, 18-8, BZP
9	108522	6	WASHER - LOCK, 1/4, SST, 18-8, BZP



REVISED 20OCT10 LVL B
 REVISED 27JUL09 LVL A
 550092 SHEET 3 OF 3 19FEB08

SERVICE PARTS LIST

2007 GM PICKUPS
 MODEL NO. - 250740 & 250743

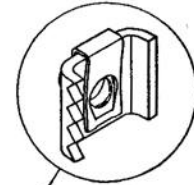

NOT USED IN FRONT APPLICATION

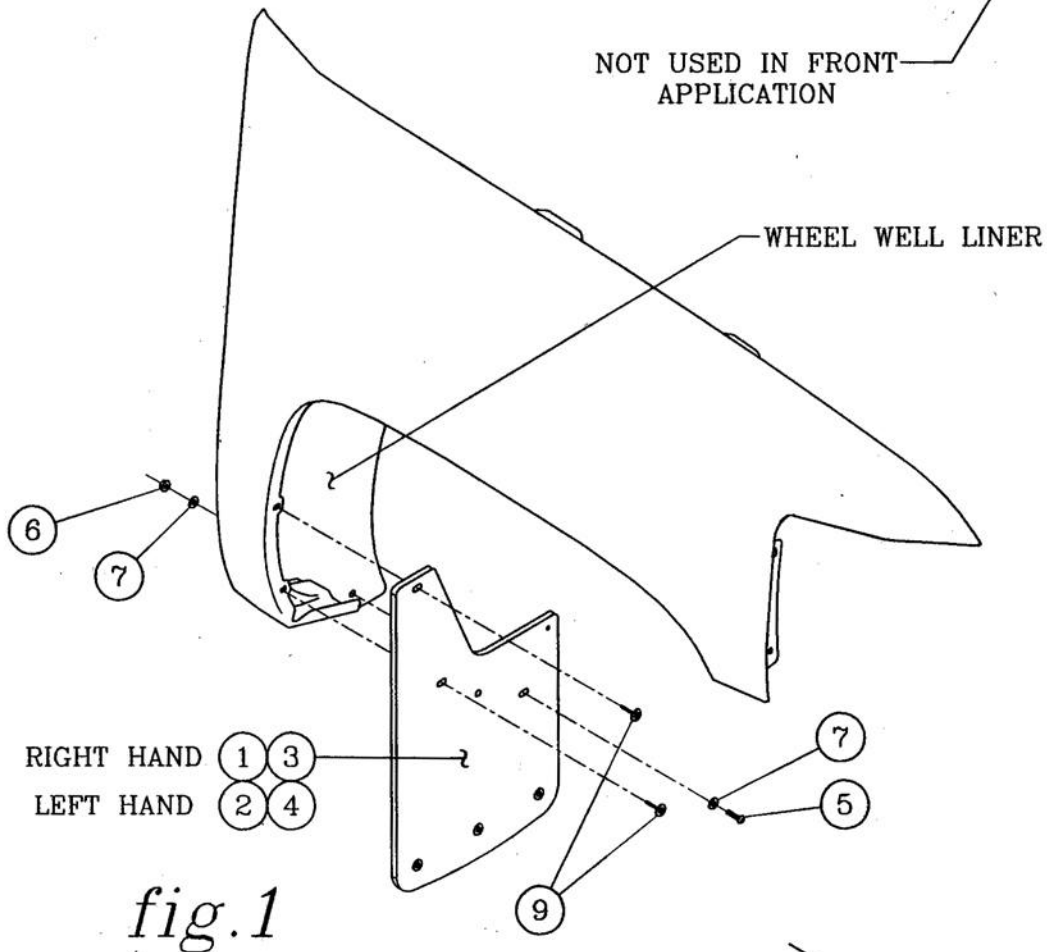

fig.1

FRONT INSTALLATION
 RIGHT (PASSENGER) SIDE SHOWN

ITEM	PART NO.	QTY	DESCRIPTION
1	550083	1	SPLASH GUARD-RUBBER,12 X 20,07,GM PICKUPS,RH
2	550084	1	SPLASH GUARD-RUBBER,12 X 20,07,GM PICKUPS,LH
3	550085	1	SPLASH GUARD-RUBBER,12 X 23,07,GM PICKUPS,RH
4	550086	1	SPLASH GUARD-RUBBER,12 X 23,07,GM PICKUPS,LH
5	108053	2	SCREW - BTN HD SOC, 1/4-20 X 1-1/4", SST, BZP
6	102366	2	NUT - HEX, SERR FLG,1/4-20, SST
7	108521	4	WASHER - FENDER, 1/4 X 1, SST, 18-8, BZP
8	105514	4	SCREW - SEMS, 7mm, HEX HD, M4.2-1.41 X 30mm

LIVERNE
 TRUCK EQUIPMENT

REVISED 20OCT10 LVL B
 REVISED 27JUL09 LVL A
 550092 SHEET 2 OF 3 19FEB08