

## INSTALLATION INSTRUCTIONS AND PARTS LIST

MODEL 583072, 583078, 583088, 584072, 584078, 584088 O-MEGA II 6" OVAL STEPS  
UNIVERSAL APPLICATION

1. READ INSTRUCTIONS COMPLETELY AND CHECK TO MAKE SURE THAT ALL REQUIRED PARTS (LISTED ON THE SERVICE PARTS LIST) ARE ON HAND BEFORE STARTING THE INSTALLATION.
2. FOLLOW THE INSTRUCTIONS INCLUDED WITH THE SPECIFIC BRACKET PACKAGE THAT YOU ARE USING, TO MOUNT THE BRACKETS TO YOUR VEHICLE.
3. BEFORE ATTACHING THE O-MEGA STEPS TO THE BRACKETS, PLACE THE STEP PADS (ITEM #2) ON TOP OF THE STEP PLATES. USE THE TABLE ON SHEET #2, AS A GUIDE TO POSITION THE STEP PAD FOR YOUR PARTICULAR VEHICLE. WHEN INSTALLING THE PADS ON THE STEPS, DRILL (5) 1/8" HOLE USING THE STEP PAD AS A GUIDE. ATTACH WITH (5) 8-18X1/2" TEK SCREWS (ITEM #6) PROVIDED. REPEAT FOR ALL STEP PADS.
4. INSTALL THE REQUIRED NUMBER OF SQUARE HEAD BOLTS INTO THE DESIGNATED SLOTS IN THE BOTTOM OF THE STEP PLATES.
5. INSTALL THE END CAPS (ITEM #3) AS SHOWN IN *fig. 1*, TIGHTENING THE NUTS TO 5 LB FT.
6. POSITION THE O-MEGA STEP ON THE MOUNTING BRACKETS SO THAT THE SQUARE HEAD SCREWS (ITEM #4) ARE LOCATED IN THE SLOTS OF THE MOUNTING BRACKETS AND THE STEP IS CENTERED, FRONT TO REAR, ON THE VEHICLE. INSTALL 5/16" SERRATED FLANGE NUTS (ITEM #5) ON THE SQUARE HEAD SCREWS (ITEM #4) AND TIGHTEN TO 19 LB FT.

### SERVICE PARTS LIST

ITEM	PART NO.	QTY	DESCRIPTION
1	553071	2	EXTRUSION-AL,69.0,OMEGA STP,SILVER
1	553072	2	EXTRUSION-AL,75.0,OMEGA STP,SILVER
1	553073	2	EXTRUSION-AL,85.0,OMEGA STP,SILVER
1	553059	2	EXTRUSION-AL,69.0,OMEGA STP,BLACK
1	553060	2	EXTRUSION-AL,75.0,OMEGA STP,BLACK
1	553061	2	EXTRUSION-AL,85.0,OMEGA STP,BLACK
2	552970	4	ALUM,STP-PAD,BLK,OMEGA-STEP
3	107956	4	CAP-END,PLSTC,2.95 X 6.70
4	106880	24	SCREW-SQ HD,5/16-18 X 1,MAGNIGUARD
5	102680	24	NUT-SERR FLG,HX,SST,WX,5/16-18
6	107958	20	SCREW-PPH,TEK,#8-18 X 1/2",SST,BZP



## STEP PAD LOCATION GUIDE



VEHICLE MODEL	PAD A	PAD B
SILVERADO/SIERRA DOUBLE CAB	14-3/4	46-3/4
SILVERADO/SIERRA EXTENDED CAB	14-3/4	41-3/4
SILVERADO/SIERRA CREW CAB	14-3/4	54-1/4
COLORADO/CANYON EXTENDED CAB	10-1/2	43
COLORADO/CANYON CREW CAB	10-1/2	51
AVALANCHE/SUBURBAN/YUKON XL	15-1/4	55-1/4
TAHOE/YUKON	15-1/4	48-1/4
RAM QUAD CAB	10-1/2	46
RAM CREW CAB	10-1/2	48
RAM MEGA CAB	10-1/2	52-1/16
DODGE DAKOTA QUAD CAB	10-1/2	39
DODGE DURANGO	15-1/4	50-1/4
FORD F150 SUPER CAB	18-1/4	46-1/4
FORD F150 SUPER CREW CAB	18-1/4	56-1/2
FORD SUPER DUTY SUPER CAB	14-1/4	42
FORD SUPER DUTY CREW CAB	12	58-1/4
TOYOTA TUNDRA DOUBLE CAB 07+	8-1/4	49-1/4
TOYOTA TUNDRA CREWMAX07+	8-1/4	54-1/4
TOYOTA TACOMA ACCESS CAB	8-1/4	30-1/5
TOYOTA TACOMA DOUBLE CAB	18-3/4	55-1/4

**NOTE: THE ABOVE PAD LOCATIONS ARE ONLY SUGGESTIONS AND MAY BE PLACED AT THE PURCHASERS DISCRETION.**

## INSTALLATION INSTRUCTIONS AND PARTS LIST

APPLICATION: MODEL **571447** MEGA STEP BRACKETS ON:

2014+ GM 1500 PICKUPS, GAS

2015 GM 2500/3500HD PICKUPS, GAS

### ROCKER PANEL MOUNT APPLICATION



#### NO DRILL APPLICATION

1. READ INSTRUCTIONS COMPLETELY AND CHECK TO MAKE SURE THAT ALL REQUIRED PARTS (LISTED ON SERVICE PARTS LIST) ARE ON HAND BEFORE STARTING THE INSTALLATION. THE SIDE ENTRY STEP ASSEMBLIES SHOULD BE MOUNTED TO THE PINCH WELD AND VERTICAL WALL OF THE ROCKER PANEL AS FOLLOWS. **NOTE: DEPENDING ON THE VEHICLE, THE HOLE CONFIGURATION MAY CHANGE. FASTENERS ARE PROVIDED FOR ALL APPLICATIONS.**
2. ON THE LEFT SIDE OF THE VEHICLE REMOVE THE PLASTIC BODY PLUGS THAT ARE LOCATED ON THE VERTICAL WALL OF THE ROCKER PANEL AND INSERT A 5/16"-18 U-NUT (ITEM #7) AS SHOWN. **NOTE: IF THERE ARE THREADED INSERTS IN THE UPPER LOCATION, USE THE BLACK M8-1.25 X 30 MM BOLTS (ITEM #9).**
3. POSITION THE MOUNTING BRACKETS (ITEM #2) SO THAT THE HOLES ON THE BRACKET LINE UP WITH THE HOLES ON THE INSIDE WALL OF THE ROCKER PANEL. INSTALL A 5/16"-18 X 1.0" HEX BOLT, AND A 5/16" FLAT WASHER (ITEMS #4, 5) FINGER TIGHT.
4. INSTALL A BLACK M8-1.25 X 30 MM HEX BOLT, 5/16" FLAT WASHER, AND THE PINCH WELD SUPPORT (ITEMS #4, 8, 9) THROUGH THE HOLE AND INSTALL A M8-1.25 NUT (ITEM #6) FINGER TIGHT ON THE BACK AS SHOWN.
5. REPEAT STEPS 3 – 4 FOR THE REMAINING BRACKETS
6. ATTACH THE SPRING HANGER MOUNTING BRACKETS (ITEM# 10, 11) AGAINST THE SIDE OF THE VEHICLE SPRING HANGER AS SHOWN.
  - 6.1 LOOSEN THE SPRING HANGER BOLT JUST ENOUGH SO THAT THE INBOARD SPRING HANGER MTG BRKT (ITEM #10) CAN BE SLID UP BEHIND THE FLANGE OF THE BOLT. POSITION THE INBOARD SPRING HANGER MOUNTING BRACKET BEHIND THE FLANGE OF THE SPRING HANGER BOLT, WITH THE CHANNEL OPEN TO THE OUTBOARD SIDE, AS SHOWN.
  - 6.2 USING A 3/8"-16 BOLT, 3/8" WASHER, 1/2" WASHER AND 3/8" LOCK NUT (ITEMS# 12-15) INSTALL THE OUTBOARD SPRING HANGER MOUNTING BRACKET (ITEM #11) SO THAT THE INBOARD VERTICAL PORTION OF THE BRACKET FITS INSIDE THE CHANNEL SHAPE OF THE INBOARD SPRING HANGER BRACKET. LEAVE THESE FASTENERS FINGER TIGHT AT THIS TIME.
7. INSTALL THE STEP BOARD AS DESCRIBED BY THE INSTRUCTIONS INCLUDED WITH YOUR STEP BOARDS.
8. PRESS STEP DOWN AND BACK, TIGHTEN THE MOUNTING BOLTS TO 19 LB-FT STARTING WITH THE BOTTOM BOLTS FOLLOWED BY THE TOP BOLTS.
9. REPEAT STEPS 2 – 8 FOR THE RIGHT SIDE OF THE VEHICLE.



(A LUVERNE Company)

## SERVICE PARTS LIST

ITEM	PART NO.	QTY	DESCRIPTION
1		1	STEP ASSY, MEGA STEP / O-MEGA STEP
2	552628	3	BRKT-MTG, LH, MS 07+ GM PICKUPS
3	552627	3	BRKT-MTG, RH, MS, 07+ GM PICKUPS
4	106998	12	5/16" – FLATWASHER SST, BZP
5	100647	6	5/16"-18 X 1.00" SCR ZP
6	105859	6	NUT SERR FLG, M8-1.25, ZP
7	105541	6	U-NUT,5/16"-18
8	551666	6	BRKT-MTG,PINCH WELD SUPPORT
9	100180	12	SCREW-HEX, M8-1.25 X 30MM, BZP
10	551806	2	BRKT-MTG,REAR,INBOARD
11	552717	2	BRKT-MTG,REAR,OUTBOARD
12	101326	2	SCREW-HEX HEAD, 3/8"-16 X 2", ZP
13	100062	4	WASHER – FLAT, 3/8", ZP
14	100118	4	WASHER – FLAT, 1/2", ZP
15	102381	2	NUT – SELF LOCKING, 3/8"-16, ZP

SERVICE PARTS LIST  
 MODEL NO. -571447

**GM REGULAR CAB**  
**GM DOUBLE CAB**  
**GM CREW CAB**

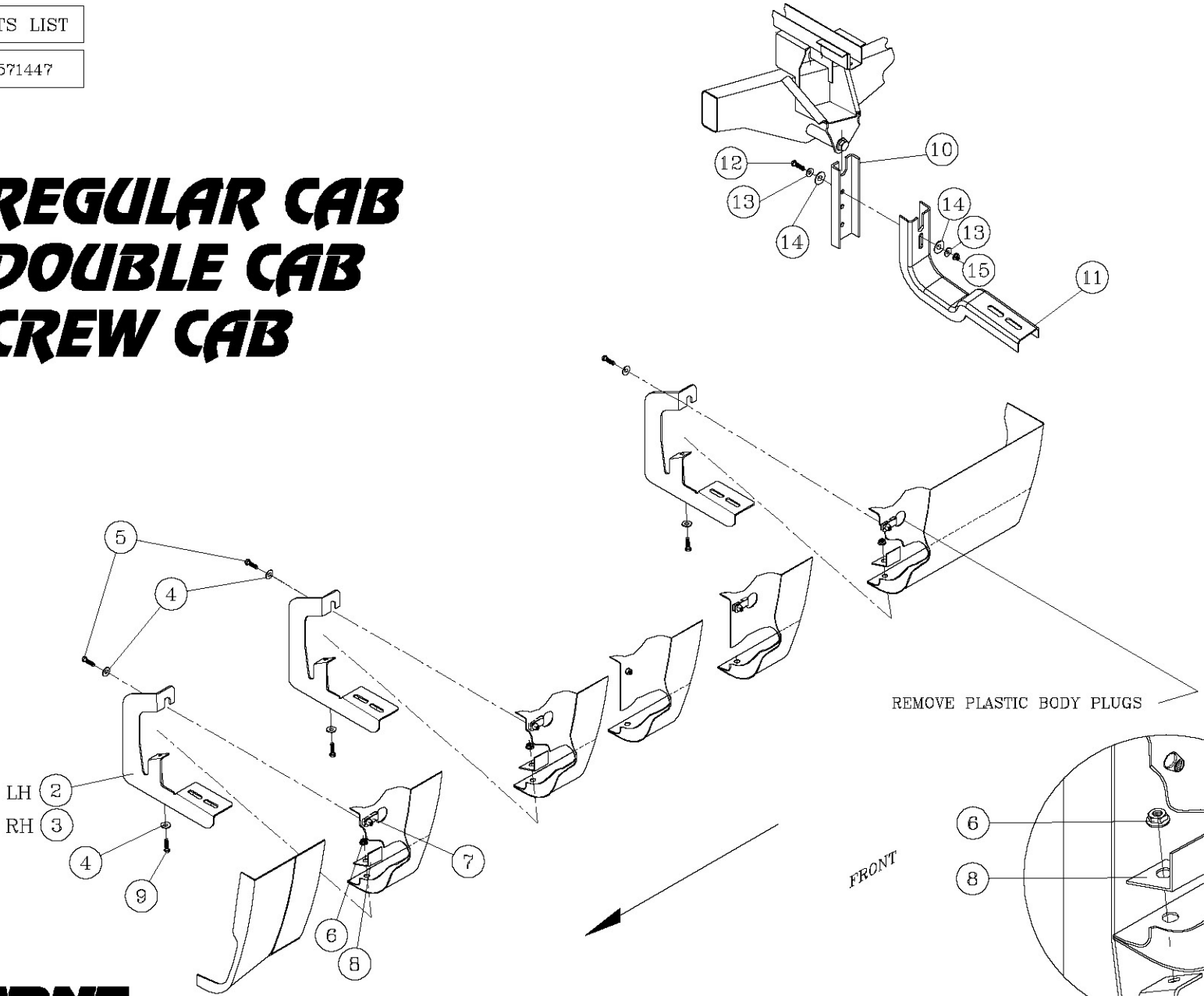

REMOVE PLASTIC BODY PLUGS

FRONT

PINCH WELD SUPPORT ASSEMBLY

LEFT (DRIVER) SIDE SHOWN  
 -RIGHT (PASSENGER) SIDE OPPOSITE-



(A LIVERNE Company)

Choose reliable running boards offered on our website.