

INSTALLATION INSTRUCTIONS AND PARTS LIST

MODEL 583072, 583078, 583088, 584072, 584078, 584088 O-MEGA II 6" OVAL STEPS
UNIVERSAL APPLICATION

1. READ INSTRUCTIONS COMPLETELY AND CHECK TO MAKE SURE THAT ALL REQUIRED PARTS (LISTED ON THE SERVICE PARTS LIST) ARE ON HAND BEFORE STARTING THE INSTALLATION.
2. FOLLOW THE INSTRUCTIONS INCLUDED WITH THE SPECIFIC BRACKET PACKAGE THAT YOU ARE USING, TO MOUNT THE BRACKETS TO YOUR VEHICLE.
3. BEFORE ATTACHING THE O-MEGA STEPS TO THE BRACKETS, PLACE THE STEP PADS (ITEM #2) ON TOP OF THE STEP PLATES. USE THE TABLE ON SHEET #2, AS A GUIDE TO POSITION THE STEP PAD FOR YOUR PARTICULAR VEHICLE. WHEN INSTALLING THE PADS ON THE STEPS, DRILL (5) 1/8" HOLE USING THE STEP PAD AS A GUIDE. ATTACH WITH (5) 8-18X1/2" TEK SCREWS (ITEM #6) PROVIDED. REPEAT FOR ALL STEP PADS.
4. INSTALL THE REQUIRED NUMBER OF SQUARE HEAD BOLTS INTO THE DESIGNATED SLOTS IN THE BOTTOM OF THE STEP PLATES.
5. INSTALL THE END CAPS (ITEM #3) AS SHOWN IN *fig. 1*, TIGHTENING THE NUTS TO 5 LB FT.
6. POSITION THE O-MEGA STEP ON THE MOUNTING BRACKETS SO THAT THE SQUARE HEAD SCREWS (ITEM #4) ARE LOCATED IN THE SLOTS OF THE MOUNTING BRACKETS AND THE STEP IS CENTERED, FRONT TO REAR, ON THE VEHICLE. INSTALL 5/16" SERRATED FLANGE NUTS (ITEM #5) ON THE SQUARE HEAD SCREWS (ITEM #4) AND TIGHTEN TO 19 LB FT.

SERVICE PARTS LIST

ITEM	PART NO.	QTY	DESCRIPTION
1	553071	2	EXTRUSION-AL,69.0,OMEGA STP,SILVER
1	553072	2	EXTRUSION-AL,75.0,OMEGA STP,SILVER
1	553073	2	EXTRUSION-AL,85.0,OMEGA STP,SILVER
1	553059	2	EXTRUSION-AL,69.0,OMEGA STP,BLACK
1	553060	2	EXTRUSION-AL,75.0,OMEGA STP,BLACK
1	553061	2	EXTRUSION-AL,85.0,OMEGA STP,BLACK
2	552970	4	ALUM,STP-PAD,BLK,OMEGA-STEP
3	107956	4	CAP-END,PLSTC,2.95 X 6.70
4	106880	24	SCREW-SQ HD,5/16-18 X 1,MAGNIGUARD
5	102680	24	NUT-SERR FLG,HX,SST,WX,5/16-18
6	107958	20	SCREW-PPH,TEK,#8-18 X 1/2",SST,BZP



STEP PAD LOCATION GUIDE



VEHICLE MODEL	PAD A	PAD B
SILVERADO/SIERRA DOUBLE CAB	14-3/4	46-3/4
SILVERADO/SIERRA EXTENDED CAB	14-3/4	41-3/4
SILVERADO/SIERRA CREW CAB	14-3/4	54-1/4
COLORADO/CANYON EXTENDED CAB	10-1/2	43
COLORADO/CANYON CREW CAB	10-1/2	51
AVALANCHE/SUBURBAN/YUKON XL	15-1/4	55-1/4
TAHOE/YUKON	15-1/4	48-1/4
RAM QUAD CAB	10-1/2	46
RAM CREW CAB	10-1/2	48
RAM MEGA CAB	10-1/2	52-1/16
DODGE DAKOTA QUAD CAB	10-1/2	39
DODGE DURANGO	15-1/4	50-1/4
FORD F150 SUPER CAB	18-1/4	46-1/4
FORD F150 SUPER CREW CAB	18-1/4	56-1/2
FORD SUPER DUTY SUPER CAB	14-1/4	42
FORD SUPER DUTY CREW CAB	12	58-1/4
TOYOTA TUNDRA DOUBLE CAB 07+	8-1/4	49-1/4
TOYOTA TUNDRA CREWMAX07+	8-1/4	54-1/4
TOYOTA TACOMA ACCESS CAB	8-1/4	30-1/5
TOYOTA TACOMA DOUBLE CAB	18-3/4	55-1/4

NOTE: THE ABOVE PAD LOCATIONS ARE ONLY SUGGESTIONS AND MAY BE PLACED AT THE PURCHASERS DISCRETION.

INSTALLATION INSTRUCTIONS AND PARTS LIST

MODEL 570553 MEGA STEPS BRACKETS:

2005 AND NEWER TOYOTA TACOMA ACCESS AND DOUBLE CAB PICKUPS
2007 AND NEWER TOYOTA FJ CRUISER



1. READ INSTRUCTIONS COMPLETELY AND CHECK TO MAKE SURE THAT ALL REQUIRED PARTS (LISTED ON SERVICE PARTS LIST) ARE ON HAND BEFORE STARTING THE INSTALLATION.
2. EXISTING MOUNTING FASTENERS (M8-1.25 FACTORY NUTS WITH SLOTTED PLASTIC PLUGS) ARE LOCATED ON THE INCLINED INTERIOR SURFACES OF THE ROCKER PANEL. THESE MOUNTING FASTENERS ARE USED FOR THIS INSTALLATION PER THE FOLLOWING INSTRUCTIONS.
3. ATTACH THE MOUNTING BRACKETS (ITEM #2) TO THE VEHICLE.
 - 3.1. POSITION THE BRACKETS ON THE VEHICLE SO THAT THE HOLES IN THE BRACKETS LINE UP WITH THE WITH THE 8mm METRIC NUTS IN THE ROCKER PANEL. ATTACH THE BRACKETS WITH M8-1.25 X 25mm (APPROX. 1.00" LONG) ZINC PLATED HEX HEAD CAP SCREW (ITEM #5) AND 5/16" ZINC PLATED FLAT WASHER (ITEM #6).
 - 3.2. EACH FRONT BRACKET USES ONE SCREW AND WASHER AS SHOWN.
 - 3.3. EACH CENTER AND REAR BRACKET USES TWO SCREWS AND WASHERS AND ONE ADDITIONAL WASHER (ITEM #7), USED AS A SPACER, BETWEEN THE BRACKET AND THE ROCKER PANEL AS SHOWN.
4. ATTACH THE STEPS (ITEM #1) TO THE MOUNTING BRACKETS.
 - 4.1. INSERT THREE (3) 5/16" SQUARE HEAD SCREWS (ITEM #3) IN THE CENTER SLOT ON THE UNDER SIDE OF THE STEP.
 - 4.2. POSITION THE STEP ON THE MOUNTING BRACKETS SO THAT THE SQUARE HEAD SCREWS ARE LOCATED IN THE SLOTS OF THE MOUNTING BRACKETS AND THE STEP IS CENTERED FRONT TO REAR.
 - 4.3. LOCATE THE STEP, IN AND OUT, AS DESIRED, INSTALL 5/16" SERRATED FLANGE NUTS (ITEM #4) ON THE SQUARE HEAD SCREWS AND TIGHTEN TO 19 LB FT.
 - 4.4. INSTALL 5/16-18 SERRATED FLANGE NUTS (ITEM #4) ON ANY UNUSED SQUARE HEAD SCREWS IN THE INBOARD SLOT OF THE STEP AND TIGHTEN TO 19 LB FT.

SERVICE PARTS LIST

ITEM	PART NO.	QTY	DESCRIPTION
1		2	MEGA STEP BOARD ASSEMBLY- (SOLD SEPARATELY) LENGTH WILL VARY DEPENDING ON APPLICATION
2	551633	6	BRKT- MTG, MEGA STEP, RH/LH, TOYOTA TACOMA
3	106880	6	SCREW-SQUARE HEAD, 5/16_18 UNC
4	102680	14	NUT-SERRATED FLANGE, HEX, SST, 5/16-18 UNC
5	102549	10	SCREW- HEX HEAD CAP, M8-1.25 X 25mm,ZP
6	100034	10	WSHR-PL, A, STL, 5/16,.375 ID X .875 OD X .083 THK, ZP
7	100062	4	WSHR-PL, A, STL, 3/8,.438 ID X 1.00 OD X .083 THK, ZP

SERVICE PARTS LIST

ACCESS & DOUBLE CAB
MODEL NO.- 570553

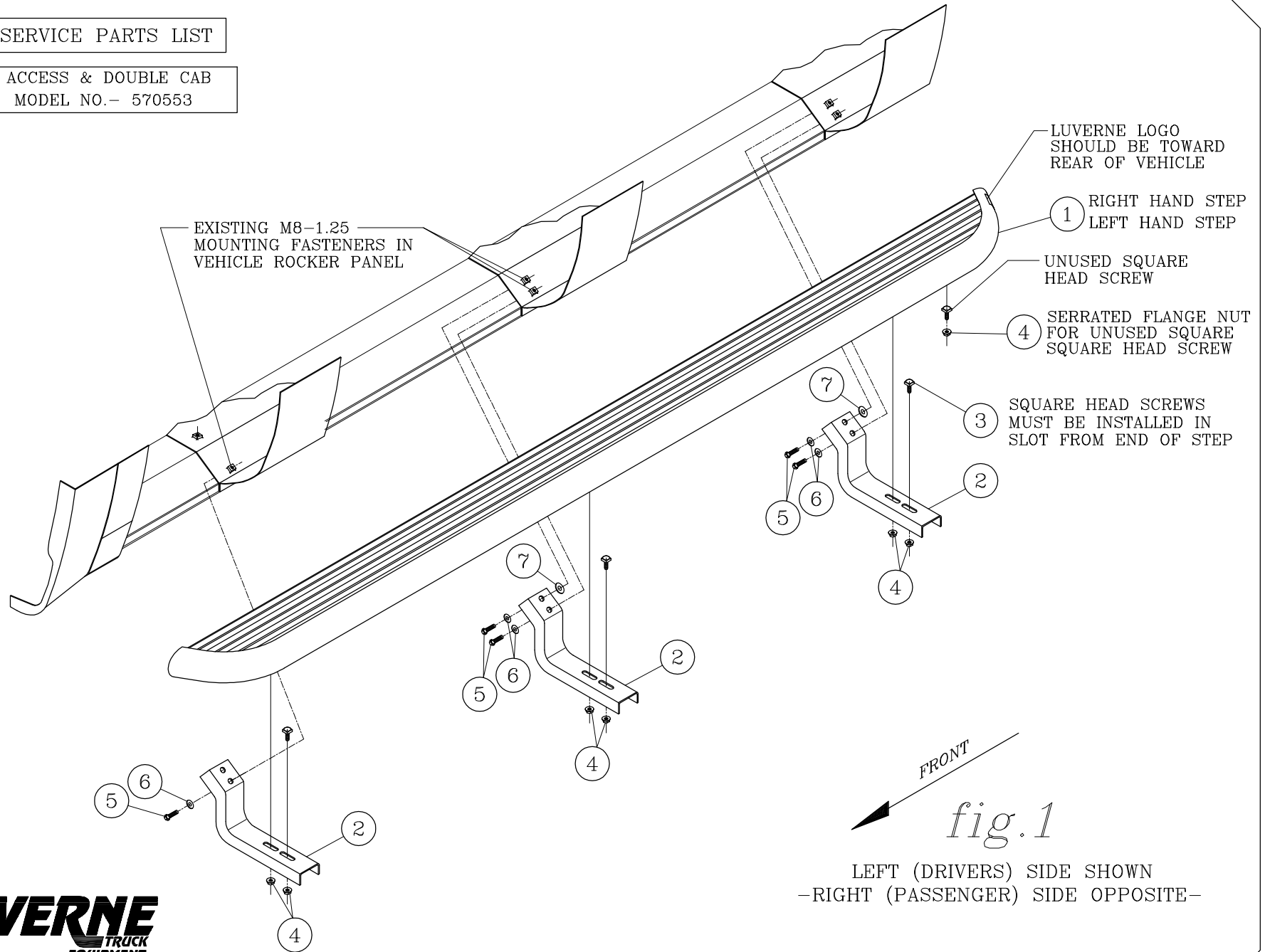

LEFT (DRIVERS) SIDE SHOWN
-RIGHT (PASSENGER) SIDE OPPOSITE-

LUVERNE
TRUCK
EQUIPMENT
INC.

Choose reliable running boards offered on our website.