

INSTALLATION INSTRUCTIONS AND PARTS LIST

MODEL 583072, 583078, 583088, 584072, 584078, 584088 O-MEGA II 6" OVAL STEPS
UNIVERSAL APPLICATION

1. READ INSTRUCTIONS COMPLETELY AND CHECK TO MAKE SURE THAT ALL REQUIRED PARTS (LISTED ON THE SERVICE PARTS LIST) ARE ON HAND BEFORE STARTING THE INSTALLATION.
2. FOLLOW THE INSTRUCTIONS INCLUDED WITH THE SPECIFIC BRACKET PACKAGE THAT YOU ARE USING, TO MOUNT THE BRACKETS TO YOUR VEHICLE.
3. BEFORE ATTACHING THE O-MEGA STEPS TO THE BRACKETS, PLACE THE STEP PADS (ITEM #2) ON TOP OF THE STEP PLATES. USE THE TABLE ON SHEET #2, AS A GUIDE TO POSITION THE STEP PAD FOR YOUR PARTICULAR VEHICLE. WHEN INSTALLING THE PADS ON THE STEPS, DRILL (5) 1/8" HOLE USING THE STEP PAD AS A GUIDE. ATTACH WITH (5) 8-18X1/2" TEK SCREWS (ITEM #6) PROVIDED. REPEAT FOR ALL STEP PADS.
4. INSTALL THE REQUIRED NUMBER OF SQUARE HEAD BOLTS INTO THE DESIGNATED SLOTS IN THE BOTTOM OF THE STEP PLATES.
5. INSTALL THE END CAPS (ITEM #3) AS SHOWN IN *fig. 1*, TIGHTENING THE NUTS TO 5 LB FT.
6. POSITION THE O-MEGA STEP ON THE MOUNTING BRACKETS SO THAT THE SQUARE HEAD SCREWS (ITEM #4) ARE LOCATED IN THE SLOTS OF THE MOUNTING BRACKETS AND THE STEP IS CENTERED, FRONT TO REAR, ON THE VEHICLE. INSTALL 5/16" SERRATED FLANGE NUTS (ITEM #5) ON THE SQUARE HEAD SCREWS (ITEM #4) AND TIGHTEN TO 19 LB FT.

SERVICE PARTS LIST

ITEM	PART NO.	QTY	DESCRIPTION
1	553071	2	EXTRUSION-AL,69.0,OMEGA STP,SILVER
1	553072	2	EXTRUSION-AL,75.0,OMEGA STP,SILVER
1	553073	2	EXTRUSION-AL,85.0,OMEGA STP,SILVER
1	553059	2	EXTRUSION-AL,69.0,OMEGA STP,BLACK
1	553060	2	EXTRUSION-AL,75.0,OMEGA STP,BLACK
1	553061	2	EXTRUSION-AL,85.0,OMEGA STP,BLACK
2	552970	4	ALUM,STP-PAD,BLK,OMEGA-STEP
3	107956	4	CAP-END,PLSTC,2.95 X 6.70
4	106880	24	SCREW-SQ HD,5/16-18 X 1,MAGNIGUARD
5	102680	24	NUT-SERR FLG,HX,SST,WX,5/16-18
6	107958	20	SCREW-PPH,TEK,#8-18 X 1/2",SST,BZP



STEP PAD LOCATION GUIDE

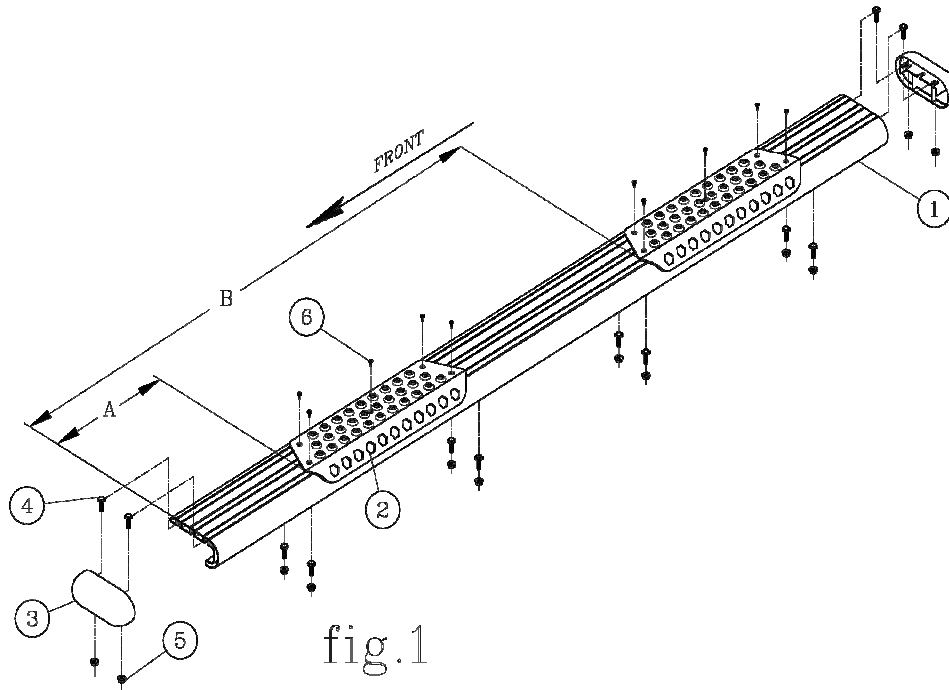

VEHICLE MODEL	PAD A	PAD B
SILVERADO/SIERRA DOUBLE CAB	14-3/4	46-3/4
SILVERADO/SIERRA EXTENDED CAB	14-3/4	41-3/4
SILVERADO/SIERRA CREW CAB	14-3/4	54-1/4
COLORADO/CANYON EXTENDED CAB	10-1/2	43
COLORADO/CANYON CREW CAB	10-1/2	51
AVALANCHE/SUBURBAN/YUKON XL	15-1/4	55-1/4
TAHOE/YUKON	15-1/4	48-1/4
RAM QUAD CAB	10-1/2	46
RAM CREW CAB	10-1/2	48
RAM MEGA CAB	10-1/2	52-1/16
DODGE DAKOTA QUAD CAB	10-1/2	39
DODGE DURANGO	15-1/4	50-1/4
FORD F150 SUPER CAB	18-1/4	46-1/4
FORD F150 SUPER CREW CAB	18-1/4	56-1/2
FORD SUPER DUTY SUPER CAB	14-1/4	42
FORD SUPER DUTY CREW CAB	12	58-1/4
TOYOTA TUNDRA DOUBLE CAB 07+	8-1/4	49-1/4
TOYOTA TUNDRA CREWMAX07+	8-1/4	54-1/4
TOYOTA TACOMA ACCESS CAB	8-1/4	30-1/5
TOYOTA TACOMA DOUBLE CAB	18-3/4	55-1/4

NOTE: THE ABOVE PAD LOCATIONS ARE ONLY SUGGESTIONS AND MAY BE PLACED AT THE PURCHASERS DISCRETION.

INSTALLATION INSTRUCTIONS AND PARTS LIST
MODEL 570717 W2W MEGA STEP BRACKETS:
2007 AND NEWER GM CREW CAB PICKUPS AND EXT CABS



1. READ INSTRUCTIONS COMPLETELY AND CHECK TO MAKE SURE THAT ALL REQUIRED PARTS (LISTED ON SERVICE PARTS LIST) ARE ON HAND BEFORE STARTING THE INSTALLATION.
2. ATTACH THE TOP OF THE MOUNTING BRACKETS (ITEM #5) TO THE VEHICLE WITH AN M8 BOLT (ITEM#2) AND WASHER (ITEM #4) **NOTE THIRD BRKT BACK WILL NEED TO USE U-NUT (ITEM #7) AND 5/16" BOLT (ITEM #6) AND WASHER (ITEM #4) TO MOUNT.** DISTANCE BETWEEN 1ST AND 2ND BRACKET WILL BE 24 INCHES.
3. INSERT A NYLON WASHER (ITEM #8) BETWEEN THE TOP OF THE MOUNTING BRACKET AND THE BOTTOM OF THE ROCKER PANEL AND INSTALL THE SCREW (ITEM#2) AND WASHER (ITEM#4) NUT AND PINCH WELD SUPPORT BRACKET (ITEM #5 &14) THIS IS DONE ON EACH MOUNTING BRACKET.TIGHTEN TO 19 LB FT.
4. ATTACH THE SPRING HANGER MOUNTING BRACKETS (ITEM # 12 & #13) AGAINST THE SIDE OF THE VEHICLE SPRING HANGER AS SHOWN.
 - 4.1 LOOSEN THE SPRING HANGER BOLT JUST ENOUGH SO THAT THE INBOARD SPRING HANGER MTG BRKT (ITEM #13) CAN BE SLID UP BEHIND THE FLANGE OF THE BOLT. POSITION THE INBOARD SPRING HANGER MTG BRKT BEHIND THE FLANGE OF THE SPRING HANGER BOLT, WITH THE CHANNEL OPEN TO THE OUTBOARD SIDE, AS SHOWN.
 - 4.2 INSTALL THE OUTBOARD SPRING HANGER MTG BRKT (ITEM #12) SO THAT THE INBOARD VERTICAL PORTION OF THE BRACKET FITS INSIDE THE CHANNEL SHAPE OF THE INBOARD SPRING HANGER MTG BRKT USING THE 3/8" ZINC PLATED BOLT (ITEM #17), WASHERS, 1/2" WASHERS, AND 3/8" ZINC PLATED NYLOCK NUT (ITEMS #9-#11) AS SHOWN. (LEAVE THE FASTENERS FINGER TIGHT).
5. PREPARE THE MEGA STEP PLATE FOR MOUNTING AS FOLLOWS. INSERT (4) 5/16" SQUARE HEAD SCREWS IN THE CENTER SLOT ON THE UNDER SIDE OF THE STEP.
 - 5.1 POSITIONS THE MEGA STEP ON THE MOUNTING BRACKETS SO THAT THE SQUARE HEAD SCREWS ARE LOCATED IN THE SLOTS OF THE MOUNTING BRACKETS AND THE STEP IS CENTERED, FRONT TO REAR, ON THE VEHICLE. INSTALL 5/16" SERRATED FLANGE NUTS, ON THE SQUARE HEAD SCREWS AND TIGHTEN TO 19 LB FT.

NOTE: FASTENERS MENTIONED IN STEPS 5 & 5.1 WILL COME IN THE STEP BOARD FASTENER PACKAGE.

- 5.2 TIGHTEN THE SPRING HANGER FLG. NUT TO 60 LB FT & THE 5/16" FASTENERS TO 19 LB FT.



SERVICE PARTS LIST

ITEM	PART NO.	QTY	DESCRIPTION
1		2	MEGA STEP BOARD ASSEMBLY (SOLD SEPARATELY) LENGTH WILL VARY DEPENDING ON APPLICATION
2	100180	12	M8 X 30 X 1.25 SCR,SST,BZP
3	551746	6	MOUNTING BRACKET, MEGASTEPE
4	102734	12	5/16" STD FLAT WASHER SST
5	105859	6	M8 FLANGED NUT ZP
6	100647	6	5/16" X 1.00" SCR ZP
7	105541	6	U-NUT 5/16" - 18
8	107182	6	WASHER-SPCR,NYLON,BLK.312 IDX 1.24 OD X .25THK
9	102381	2	NUT-NYLOCK, HEX, 3/8-16, ZP
10	100118	4	WASHER-FL, 1/2",ZP
11	100062	4	WASHER- FL,3/8",ZP
12	551669	2	BRKT-MTG,REAR,OUTBRD,571117
13	551806	2	BRKT-MTG,REAR,INBRD,571117
14	551666	6	BRKT-MTG,PINCH WELD SUPPORT
15	101326	2	BOLT,HEX HEAD,3/8-16 X 2.00,ZP

SERVICE PARTS LIST

MODEL NO. -570717

NOTE:
THE MOUNTING PATTERNS MAY NOT BE EXACTLY AS SHOWN. HOWEVER THERE WILL BE ENOUGH FASTENERS TO MAKE THE APPLICATION.

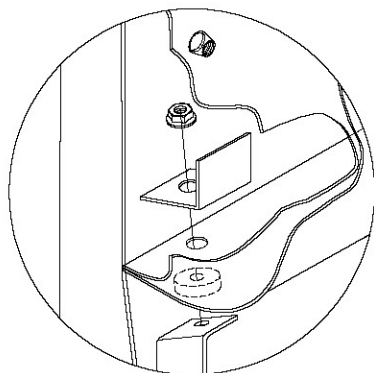

PINCH WELD SUPPORT ASSEMBLY

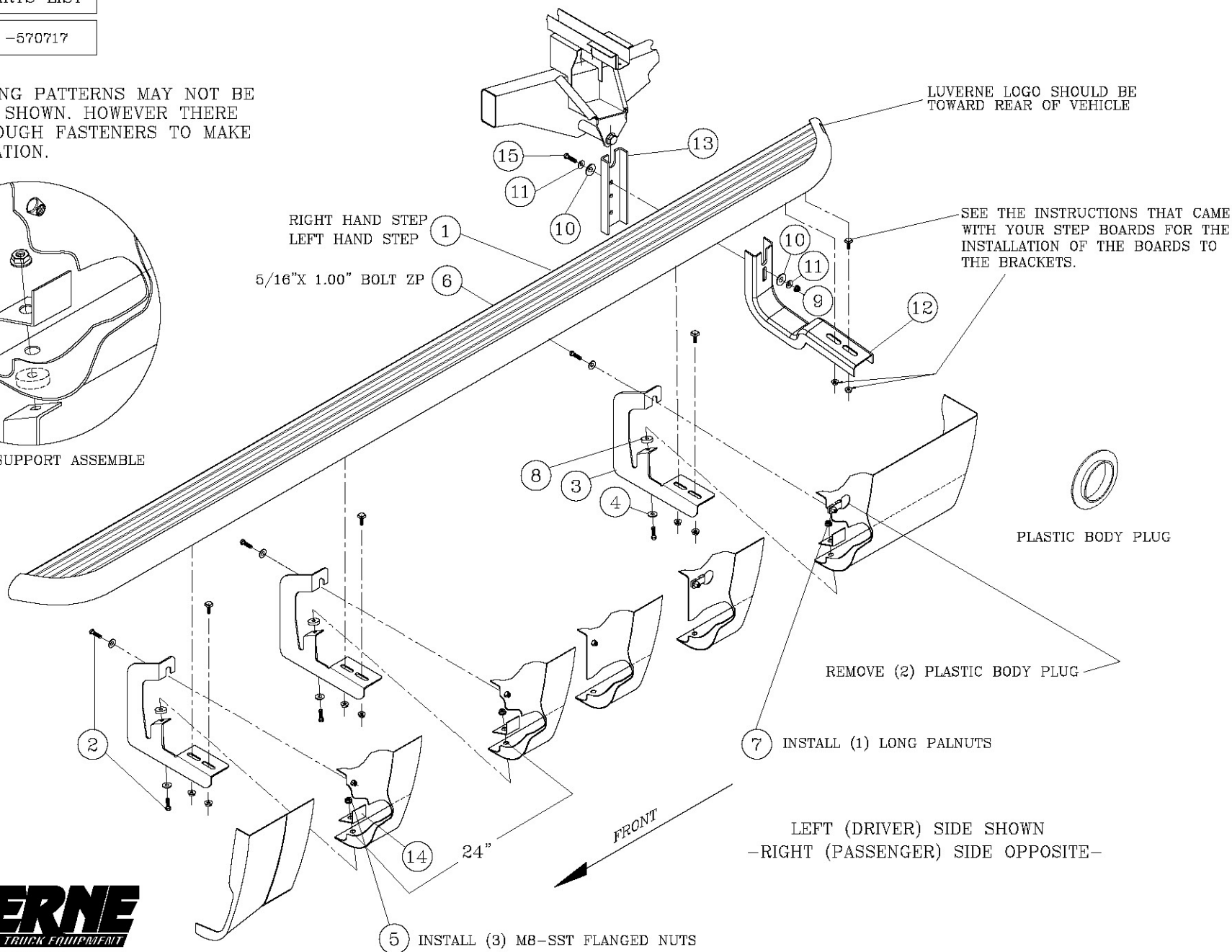

Choose reliable running boards offered on our website.