

# INSTALLATION INSTRUCTIONS AND PARTS LIST

MODEL 583100, 584100 O-MEGA II 6" OVAL STEPS  
UNIVERSLA APPLICATION

1. READ INSTRUCTIONS COMPLETELY AND CHECK TO MAKE SURE THAT ALL REQUIRED PARTS (LISTED ON THE SERVICE PARTS LIST) ARE ON HAND BEFORE STARTING THE INSTALLATION.
2. FOLLOW THE INSTRUCTIONS INCLUDED WITH THE SPECIFIC BRACKET PACKAGE THAT YOU ARE USING, TO MOUNT THE BRACKETS TO YOUR VEHICLE.
3. BEFORE ATTACHING THE O-MEGA STEPS TO THE BRACKETS, PLACE THE STEP PADS (ITEM #3) ON TOP OF THE STEP PLATES ACCORDINGLY FOR YOUR VEHICLE. USING THE HOLES IN THE STEP PAD AS A GUIDE DRILL (5) 1/8" PILOT HOLES. ATTACH WITH (5) 8-18X1/2" TEK SCREWS (ITEM #7) PROVIDED. REPEAT FOR ALL STEP PADS.
4. INSTALL THE REQUIRED NUMBER OF SQUARE HEAD BOLTS INTO THE DESIGNATED SLOTS IN THE BOTTOM OF THE STEP PLATES.
5. INSTALL THE END CAPS (ITEM #4) AS SHOWN IN *fig. 1*, TIGHTENING THE NUTS TO 5 LB FT.
6. POSITION THE O-MEGA STEP ON THE MOUNTING BRACKETS SO THAT THE SQUARE HEAD SCREWS (ITEM #5) ARE LOCATED IN THE SLOTS OF THE MOUNTING BRACKETS AND THE STEP IS CENTERED, FRONT TO REAR, ON THE VEHICLE. INSTALL 5/16" SERRATED FLANGE NUTS (ITEM #6) ON THE SQUARE HEAD SCREWS (ITEM #5) AND TIGHTEN TO 19 LB FT.

## SERVICE PARTS LIST

ITEM	PART NO.	QTY	DESCRIPTION
1	553068	1	EXTRUSION-AL,33.00"OMEGA STP, SILVER
2	553074	1	EXTRUSION-AL,95.00"OMEGA STP, SILVER
1	553056	1	EXTRUSION-AL,33.00"OMEGA STP, BLACK
2	553062	1	EXTRUSION-AL,95.00"OMEGA STP, BLACK
3	552970	4	ALUM,STP-PAD,BLK,OMEGA-STEP
4	107956	4	CAP-END,PLSTC,2.95 X 6.70
5	106880	18	SCREW-SQ HD,5/16-18 X 1,MAGNIGUARD
6	102680	18	NUT-SERR FLG,HX,SST,WX,5/16-18
7	107958	24	SCREW-PPH,TEK,#8-18 X 1/2",SST,BZP



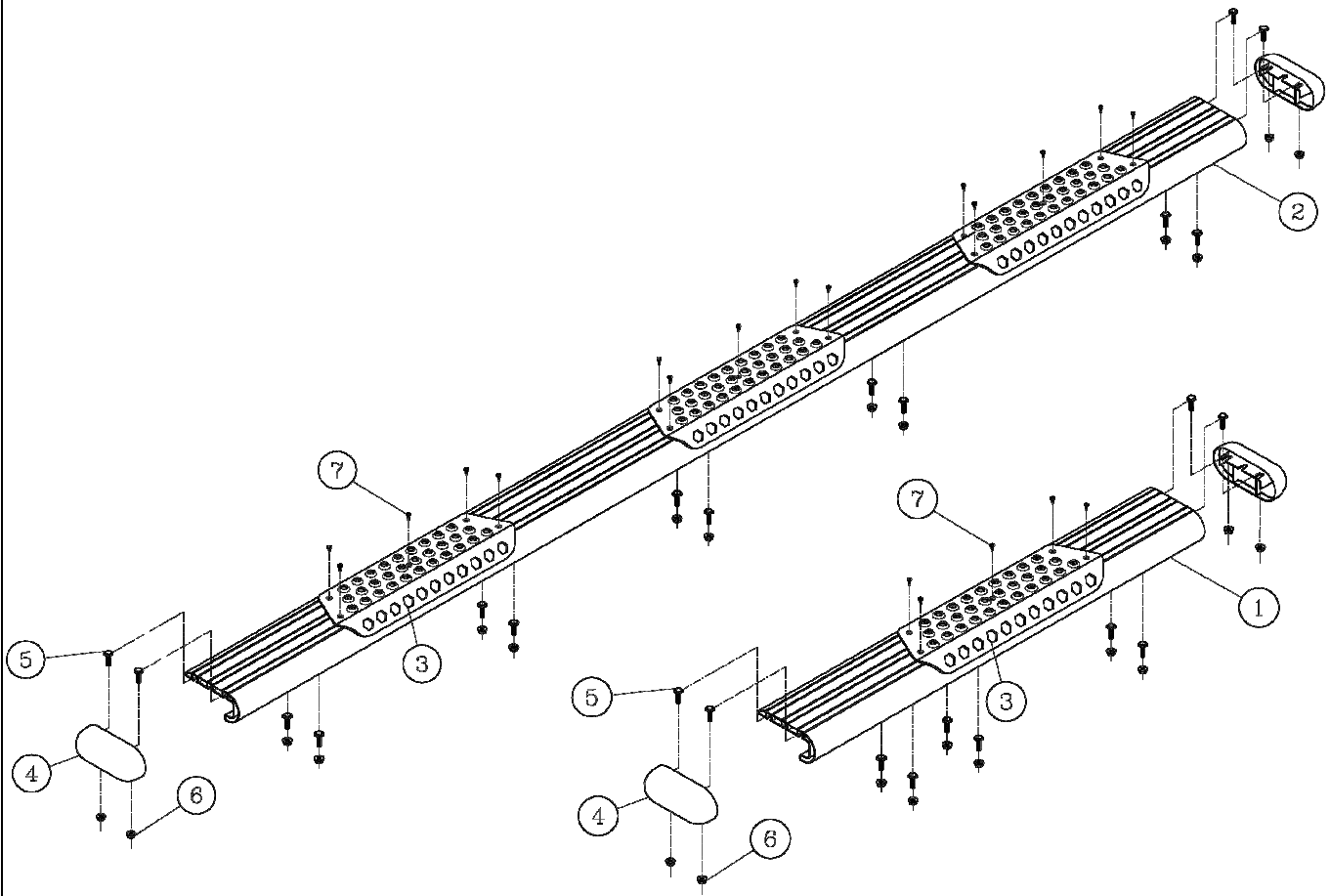

**LIVERNE**  
TRUCK EQUIPMENT

# INSTALLATION INSTRUCTIONS AND PARTS LIST

## FOR MOUNTING 570744 MEGA/OMEGA STEPS 2007-NEWER SPRINTER VANS

READ INSTRUCTIONS COMPLETELY AND CHECK TO MAKE SURE THAT ALL REQUIRED PARTS (LISTED ON SERVICE PARTS LIST) ARE ON HAND BEFORE STARTING THE INSTALLATION.

### **DRIVERS SIDE INSTALLATION**

1. PREASSEMBLE BRACKETS (ITEM 1) WITH SPACER BRACKETS (ITEM 8), USING THE 5/16-18 BOLTS WITH THE 5/16" WASHERS AND THE FLANGE NUTS (ITEMS 2, 10 & 11). FINGER TIGHTEN THEM ONLY AT THIS TIME.
2. ATTACHING THE FRONT BRACKET:
  - 2.1 ON THE BACK SIDE OF THE ROCKER PANEL, MEASURE ABOUT 9-1/2" BACK FROM THE FRONT OF THE MUD FLAP. IN THIS LOCATION THERE SHOULD BE A BODY PLUG
  - 2.2 IF THE TRUCK DOES NOT HAVE REAR A/C SCRAPE THE UNDER COATING OFF AROUND THE BODY PLUG AND REMOVE THE PLUG. THEN DRILL A 7/16" HOLE 1/2" TO THE FRONT OF THE BODY PLUG HOLE AND INSERT THE 5/16-18 U-NUT. (ITEM #4) PLACE BRACKET IN PLACE USING THE TOP SLOT AND FASTEN USING THE 5/16-18 BOLT AND WASHER. (ITEM # 2 & 10)
  - 2.3 IF THE TRUCK DOES HAVE REAR A/C YOU WILL NOT NEED TO REMOVE THE BODY PLUG INSTEAD PLACE THE PREASSEMBLED BRACKET INTO PLACE AND MARK THE HOLE LOCATION USING THE CENTER ROUND HOLE IN THE BRACKET AS A GUIDE. (MAKE SURE THAT THE BRACKET IS LEVEL WITH THE TRUCK) REMOVE THE BRACKET AND CENTER PUNCH THE MARKED HOLE AND DRILL WITH A 7/32 DRILL. PLACE BRACKET BACK IN PLACE AND INSTALL THE 1/4" SELF-TAPPING SCREW (ITEM #5). SEE FIG 1.
  - 2.4 ONCE THE BRACKET IS IN PLACE THE LOWER MOUNT IS READY TO BE DRILLED. USING A 11/32 DRILL BIT THE TWO HOLES IN THE LOWER BRACKET MOUNT CAN BE USED AS A DRILLING GUIDE.
  - 2.5 ONCE THE DRILLING IS DONE FASTEN THE BRACKET TO THE PINCH WELD USING THE SUPPLIED BLACK 5/16-18 BOLT AND 5/16 WASHER THROUGH THE DRILLED HOLES. ON THE BACK SIDE OF THE PINCH WELD PLACE THE RETAINER PLATE (ITEM #9) OVER THE BOLTS AND FASTEN THEM WITH THE SUPPLIED FLANGE NUT (ITEM #11), AND TIGHTEN DOWN ALL THE FASTENERS.
3. ATTACHING THE REAR BRACKET:
  - 3.1 ON THE BACK SIDE OF THE ROCKER PANEL, MEASURE ABOUT 27 1/2" BACK FROM THE FRONT OF THE MUD FLAP. THIS IS ABOUT WHERE THE SECOND BRACKET WILL BE INSTALLED.
  - 3.2 MEASURE THE HEIGHT OF THE FIRST BRACKET FROM THE TOP OF THE BRACKET TO THE BOTTOM OF THE FLOOR BOARD; THIS WILL HELP WITH MOUNTING THE BOARD LEVEL.
  - 3.3 USING THE BRACKET AS A GUIDE MARK THE HOLE USING THE TOP SLOT IN THE BRACKET. CENTER PUNCH AND DRILL USING A 7/32 DRILL BIT.
  - 3.4 POSITION THE BRACKET OVER THE HOLE JUST DRILLED AND FASTEN USING THE SUPPLIED SELF-TAPPING SCREW (ITEM #5). HAND TIGHTEN ONLY AT THIS TIME.
  - 3.5 WITH THE BRACKET IN PLACE REPEAT STEPS 2.4 & 2.5.



## **PASSANGER SIDE INSTALLATION**

1. PREASSEMBLE BRACKETS (ITEMS #1 & 3) WITH SPACER BRACKETS (ITEM 8), USING THE 5/16-18 BOLTS WITH THE 5/16 WASHERS AND THE FLANGE NUTS (ITEMS 2, 10 & 11). FINGER TIGHTEN THEM ONLY AT THIS TIME.
2. ATTACHING THE FRONT TWO BRACKETS WILL BE THE SAME AS THE DRIVERS SIDE, STEPS 2 THRU 3.
3. ATTACHING REAR BRACKETS:
  - 3.1 ON THE BACK SIDE OF THE ROCKER PANEL, MEASURE 48-1/2 “ BACK FROM THE FRONT OF THE MUD FLAP. IN THIS LOCATION THERE SHOULD BE A BODY PLUG. SCRAP AWAY THE UNDER COATING AND REMOVE THE BODY PLUG. MEASURE BACK 1/2” FROM THE OPENING AND DRILL A 7/16” HOLE, AND INSERT THE 5/16-18 U-NUT (ITEM #4). PLACE THE PREASSEMBLED BRACKETS (ITEM #3 & 8) IN PLACE, USING THE TOP SLOT IN THE MAIN BRACKET FASTEN WITH THE SUPPLIED FASTENERS (ITEM #2 & 10) TO THE U-NUT.
  - 3.2 USING THE LOWER BRACKET AS A GUIDE DRILL TWO 11/32” HOLES INTO THE PINCH WELD. FASTEN THEM USING THE SAME STEPS IN STEP 2.5.
  - 3.3 USING THE SAME STEPS AS ABOVE MEASURE BACK 68-1/2” AND 88-1/2” THERE WILL BE BODY PLUGS IN THESE LOCATIONS.
  - 3.4 THE BODY PLUG LOCATIONS USED WILL BE THE SECOND, FORTH, AND SIXTH LOCATIONS.
4. ATTACHEING THE STEP ASSEMBLY:  
PLEASE REVIEW THE INSTALLATION INSRTUCTIONS THAT ARE INCLUDED IN YOU STEP ASSEMBLY FOR SPECIFIC DETAILS.

## **SERVICE PARTS LIST**

<b>ITEM</b>	<b>PART NO.</b>	<b>QTY</b>	<b>DESCRIPTION</b>
1	551959	4	BRACKET-MTG, SPRNTR, 12 GA, LH/RH
2	100034	14	WASHER-FL, 5/16, ZP
3	551938	3	BRACKET-MTG, 12 GA, 2.00 LH/RH
4	105541	5	NUT-U, MULTI THD, LG, 5/16-18, BLK
5	105537	3	SCR-HWH, TF, AB, SST, 5/16 X 1.00
6	106997	14	SCR-HHCAP, 5/16-18 X 1.00, SST, BZP
7	106998	14	WASHER-FL, 5/16, BZP
8	552288	7	SPACER BRACKET, 7 GA, LH/RH
9	552289	7	PLATE-RETAINER, GALV, 7 GA
10	100647	12	SCR-HEX HD, 5/16-18 X 1.00 STL, ZP
11	100178	21	NUT-HEX FLG, 5/16-18



SERVICE PARTS LIST

BRACKET NO. - 570744

fig. 2

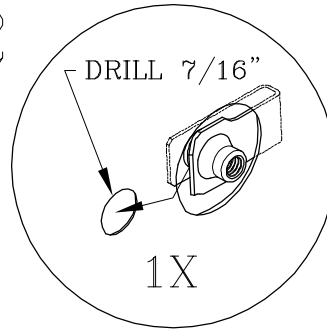
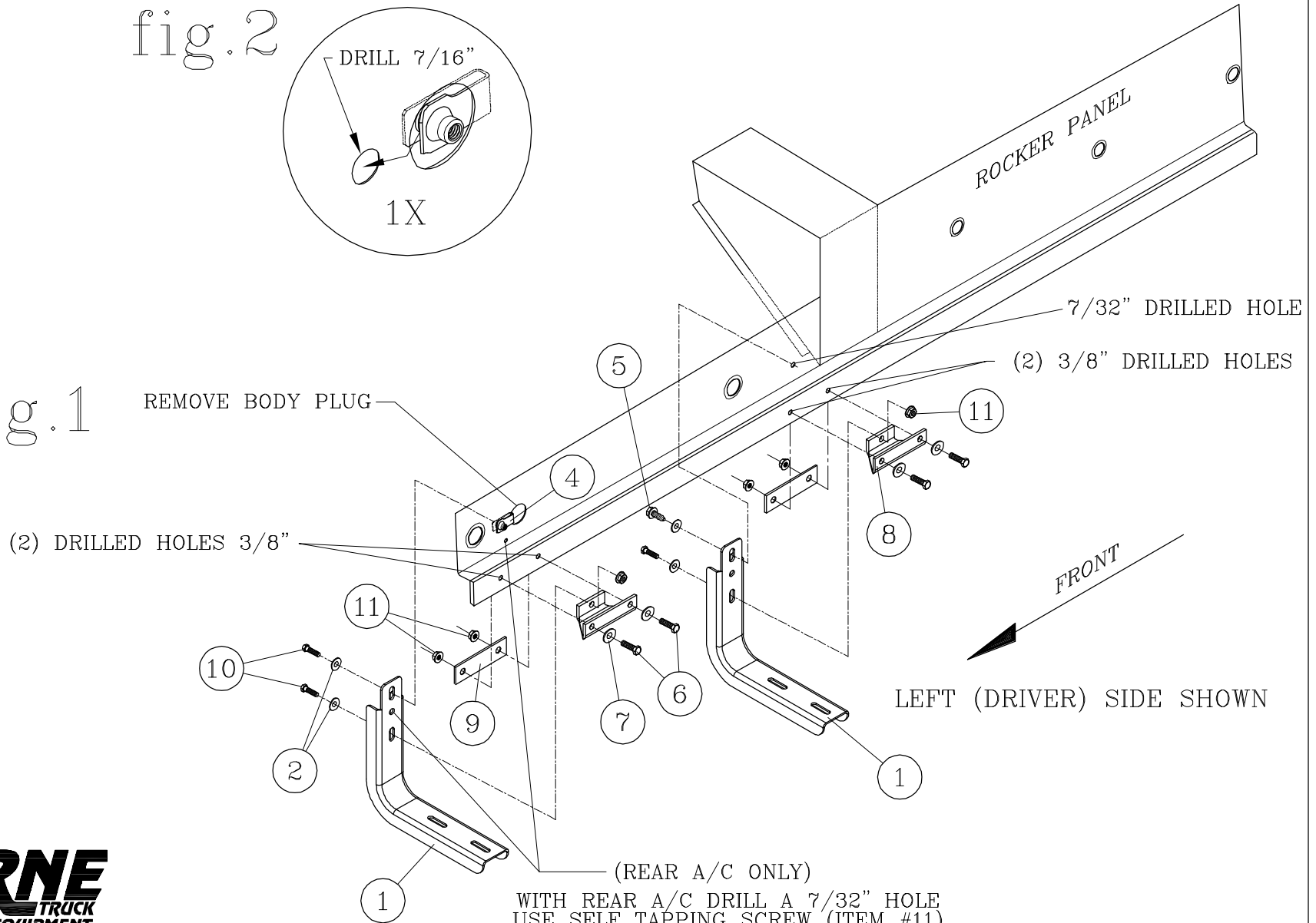

fig. 1



WITH REAR A/C DRILL A 7/32" HOLE  
USE SELF TAPPING SCREW (ITEM #11)  
AND USE MIDDLE 3/8" HOLE IN BRACKET

SERVICE PARTS LIST

BRACKET NO. - 570744

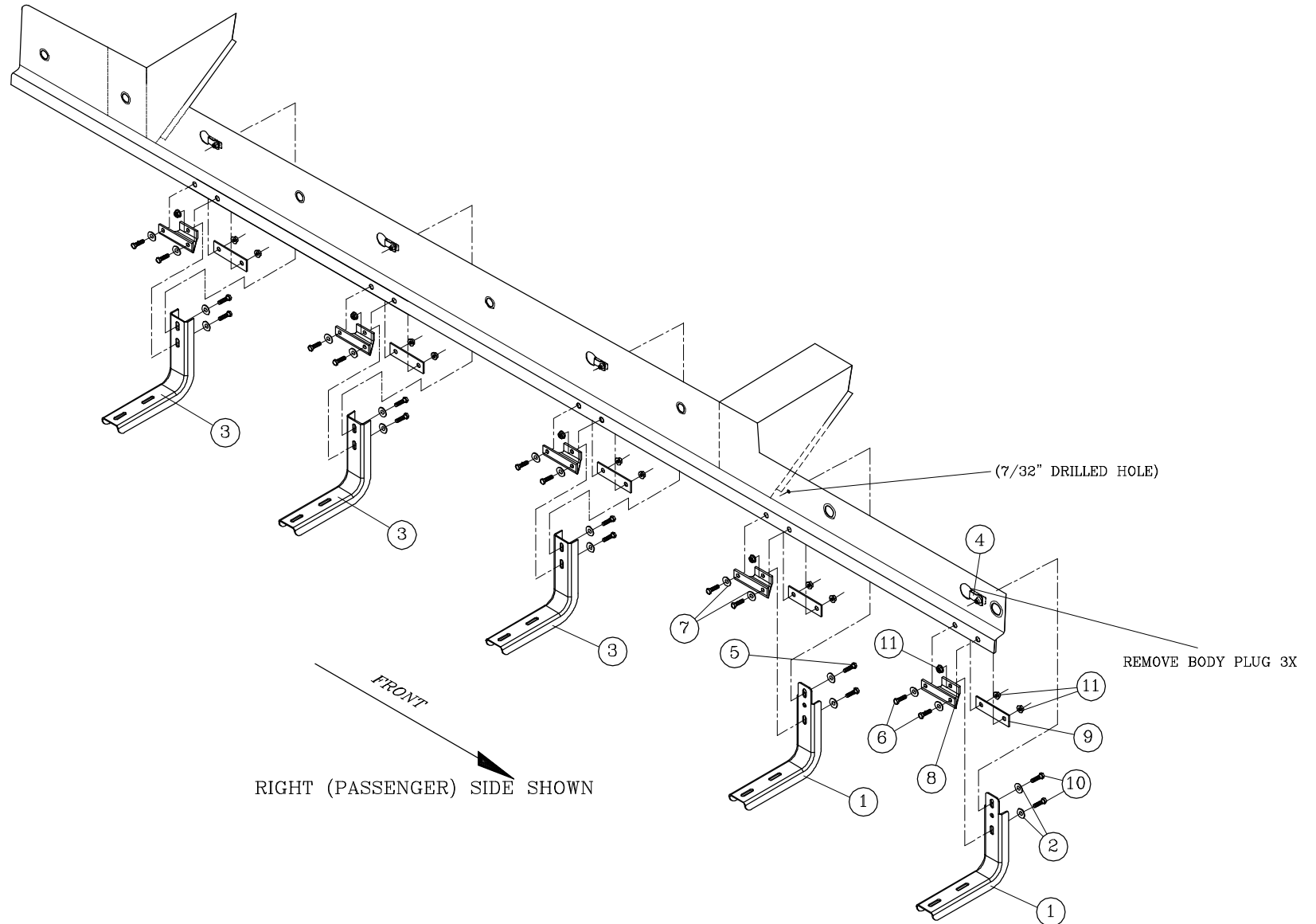

Choose reliable running boards offered on our website.