

INSTALLATION INSTRUCTIONS AND PARTS LIST

MODEL: 583098, 583102, 583108, 583114, 583125, 584098, 584102, 584114, 584125 O-MEGA II 6" OVAL
STEPS
UNIVERSAL APPLICATION

1. READ INSTRUCTIONS COMPLETELY AND CHECK TO MAKE SURE THAT ALL REQUIRED PARTS (LISTED ON THE SERVICE PARTS LIST) ARE ON HAND BEFORE STARTING THE INSTALLATION.
2. FOLLOW THE INSTRUCTIONS INCLUDED WITH THE SPECIFIC BRACKET PACKAGE THAT YOU ARE USING, TO MOUNT THE BRACKETS TO YOUR VEHICLE.
3. BEFORE ATTACHING THE O-MEGA STEPS TO THE BRACKETS, PLACE THE STEP PADS (ITEM #2) ON TOP OF THE STEP PLATES. USE THE TABLE ON SHEET #2, AS A GUIDE TO POSITION THE STEP PAD FOR YOUR PARTICULAR VEHICLE. WHEN INSTALLING THE PADS ON THE STEPS, DRILL (5) 1/8" HOLE USING THE STEP PAD AS A GUIDE. ATTACH WITH (5) 8-18X1/2" TEK SCREWS (ITEM #6) PROVIDED. REPEAT FOR ALL STEP PADS. (NOTE: DUE TO THE SHORTNESS OF SOME BOXES, MOUNT THE BOX STEP PAD FIRST, APPROXIMATELY 1/2" FROM THE END CAP AND THEN MOUNT THE MIDDLE STEP PAD ACCORDINGLY.)
4. INSTALL THE REQUIRED NUMBER OF SQUARE HEAD BOLTS INTO THE DESIGNATED SLOTS IN THE BOTTOM OF THE STEP PLATES.
5. INSTALL THE END CAPS (ITEM #3) AS SHOWN IN *fig. 1*, TIGHTENING THE NUTS TO 5 LB FT.
6. POSITION THE O-MEGA STEP ON THE MOUNTING BRACKETS SO THAT THE SQUARE HEAD SCREWS (ITEM #4) ARE LOCATED IN THE SLOTS OF THE MOUNTING BRACKETS AND THE STEP IS CENTERED, FRONT TO REAR, ON THE VEHICLE. INSTALL 5/16" SERRATED FLANGE NUTS (ITEM #5) ON THE SQUARE HEAD SCREWS (ITEM #4) AND TIGHTEN TO 19 LB FT.

SERVICE PARTS LIST

ITEM	PART NO.	QTY	DESCRIPTION
1	553074	2	EXTRUSION-AL,95.0,OMEGA STP,SILVEER
1	553075	2	EXTRUSION-AL,99.0,OMEGA STP,SILVER
1	553076	2	EXTRUSION-AL,105.0,OMEGA STP,SILVER
1	553077	2	EXTRUSION-AL,111.0,OMEGA STP,SILVER
1	553078	2	EXTRUSION-AL,122.0,OMEGA STP,SILVER
1	553062	2	EXTRUSION-AL,95.0,OMEGA STP,BLACK
1	553063	2	EXTRUSION-AL,99.0,OMEGA STP,BLACK
1	553065	2	EXTRUSION-AL,111.0,OMEGA STP,BLACK
1	553066	2	EXTRUSION-AL,122.0,OMEGA STP,BLACK
2	107957	6	ALUM,STP-PAD,BLK,OMEGA-STEP
3	107956	4	CAP-END,PLSTC,2.95 X 6.70
4	106880	28	SCREW-SQ HD,5/16-18 X 1,MAGNIGUARD
5	102680	28	NUT-SERR FLG,HX,SST,WX,5/16-18
6	107958	30	SCREW-PPH,TEK,#8-18 X 1/2",SST,BZP



STEP PAD LOCATION GUIDE



VEHICLE MODEL	PAD A	PAD B
SILVERADO/SIERRA DOUBLE CAB	14-3/4	46-3/4
SILVERADO/SIERRA EXTENDED CAB	14-3/4	41-3/4
SILVERADO/SIERRA CREW CAB	14-3/4	54-1/4
CHEVROLET EXPRESS VAN & GMC SAVANA VAN	7-1/2	N/A
RAM QUAD CAB	10-1/2	46
RAM CREW CAB	10-1/2	48
RAM MEGA CAB	10-1/2	52-1/16
FORD F150 SUPER CAB	18-1/4	46-1/4
FORD F150 SUPER CREW CAB	18-1/4	56-1/2
FORD F150 SUPER CREW CAB	18-1/4	56-1/2
FORD SUPER DUTY SUPER CAB	6-7/8	39-1/16
FORD SUPER DUTY CREW CAB	6-7/8	52-7/8
FORD	7-1/2	N/A

NOTE: THE ABOVE PAD LOCATIONS ARE ONLY SUGGESTIONS AND MAY BE PLACED AT THE PURCHASERS DISCRETION.

INSTALLATION INSTRUCTIONS AND PARTS LIST

FOR MOUNTING 401475/571475 MEGA/GRIP STEPS 2014-NEWER RAM PROMASTER VANS

READ INSTRUCTIONS COMPLETELY AND CHECK TO MAKE SURE THAT ALL REQUIRED PARTS (LISTED ON SERVICE PARTS LIST) ARE ON HAND BEFORE STARTING THE INSTALLATION.

DRIVERS SIDE INSTALLATION

1. PREASSEMBLE BRACKETS (ITEM 1) WITH SPACER BRACKETS (ITEM 6), USING THE 5/16-18 BOLTS WITH THE 5/16" WASHERS AND THE FLANGE NUTS (ITEMS #9, 14 & 15). FINGER TIGHTEN THEM ONLY AT THIS TIME.
2. MARK THE PINCH WELD FOR THE FRONT HOLE OF EACH BRACKET AS SHOWN IN FIG. 3.
3. ATTACHING THE FRONT BRACKET:
 - 3.1 TAKING THE BRACKET ASSEMBLY LINE IT UP THE BRACKET WITH THE HOLE MARKED AND MARK THE OTHER HOLE. REMOVE THE BRACKET ASSEMBLY AND DRILL THE MARKED LOCATIONS USING AN 11/32 DRILL BIT.
 - 3.2 FASTEN THE BRACKET TO THE PINCH WELD USING THE SUPPLIED FASTENERS. (ITEM #12, 13, & 15)
 - 3.3 THE TOP HOLE WILL BE DRILLED AT A LATER TIME.
4. ATTACHING THE SECOND BRACKET:
 - 4.1 LOCATE THE VERTICAL BODY LINE DIRECTLY BEHIND THE DRIVERS DOOR, AND FOLLOW THAT LINE DOWN TO THE PINCH WELD. THE SECOND BRACKET (ITEM #2) WILL MOUNT BEHIND THAT LINE. AS SHOWN IN FIG. 3.
 - 4.2 PLACE THE SECOND BRACKET (ITEM #2) UP TO THE INSIDE OF THE PINCH WELD AND SECURE IT USING A CLAMP. SOME UNDER COATING WILL NEED TO BE SCRAPED OFF SO THE BRACKET WILL SIT FLAT WITH THE PINCH WELD.
 - 4.3 USING THE HOLES AS A REFERENCE, MARK THE CENTER OF ALL (4) HOLES AND REMOVE THE BRACKET FOR DRILLING. THE TWO HOLES MARKED ON THE PINCH WELD ALONG WITH THE HOLE MARKED TOWARD THE REAR OF THE VEHICLE ON THE ANGLED SURFACE WILL BE DRILLED WITH A 11/32 DRILL BIT, WHILE THE LAST HOLE TOWARD THE FRONT OF THE VEHICLE ON THE ANGLED SURFACE WILL BE DRILLED WITH A 3/16 DRILL BIT.
 - 4.4 REMOVE THE BODY PLUG ON THE ANGLED SURFACE TOWARD THE REAR OF THE VEHICLE, A 11/32 HOLE SHOULD HAVE BEEN DRILLED NEAR THE BODY PLUG. SOME UNDER COATING WILL NEED TO BE REMOVED SO THAT THE ¼-20 U-NUT (ITEM #10) WILL SLIDE IN PLACE OVER THE 11/32 HOLE.
 - 4.6 PLACE THE BRACKET (ITEM # 2) AND FASTEN THE BRACKET TO THE PINCH WELD USING THE 5/16-18 BOLTS, WASHERS, NUTS, AND RETAINER PLATE (ITEM #5, 9, 14, 15). LEAVE THEM LOOSE AT THIS TIME. LOCATE THE U-NUT (ITEM #10) AND FASTEN USING THE ¼-20 BOLT AND WASHER (ITEM #16 &17). LOCATE THE 3/16 HOLE AND FASTEN USING THE 5/16 X ¾ SELF TAPPING SCREW (ITEM #11)
 - 4.7 TIGHTEN ALL FASTENERS FOR THE SECOND BRACKET AT THIS TIME.



(A LUVERNE Company)

5. DRILLING THE TOP HOLE OF THE FRONT BRACKET.

5.1 PLACE A STRAIGHT EDGE ON THE FLAT PLACE OF THE SECOND BRACKET (ITEM #2), HAVE THE STRAIGHT EDGE SITTING LEVEL WITH THE VEHICLE AND MOVE THE FRONT BRACKET UP OR DOWN SO THAT THE FLAT SURFACE IS LEVEL WITH THE STRAIGHT EDGE. FASTEN THE FRONT BRACKET WITH THE SPACER BRACKET SO THAT THEY ARE SNUG. LOCATE THE TOP HOLE OF THE FRONT BRACKET (ITEM #1) AND MARK THE CENTER OF THE HOLE. REMOVE THE BRACKET ASSEMBLY AND USING AN 11/32 DRILL LOCATE THE MARK THAT WAS MADE AND DRILL THE HOLE. REMOVE THE BODY PLUG LOCATED JUST NEXT TO WHERE THE HOLE WAS DRILLED. INSTALL THE U-NUT (ITEM #10) THROUGH THE BODY PLUG HOLE AND POSITION IT OVER THE 11/32 HOLE. (SOME UNDER COATING MAY NEED TO BE REMOVED IN ORDER TO INSTALL THE U-NUT PROPERLY). REINSTALL THE PREASSEMBLED BRACKET USING THE FASTENERS FOR THE PINCH WELD AREA (ITEM # 12, 13, & 15) AND USING THE SUPPLIED FASTENERS FOR THE INNER ROCKER PANEL AREA (ITEM# 16 & 17). TIGHTEN ALL FASTENERS AT THIS TIME.

REAR BRACKETS INSTALLATION

1. PREASSEMBLE BRACKETS (ITEM #8) WITH SPACER BRACKETS (ITEM 7), USING THE 5/16-18 BOLTS WITH THE 5/16 WASHERS AND THE FLANGE NUTS (ITEMS # 9, 14 & 15). FINGER TIGHTEN THEM ONLY AT THIS TIME.
2. MEASURE THE DISTANCE BETWEEN THE PINCH WELD AND THE HORIZONTAL SURFACE OF THE SECOND BRACKET AND RECORD IT. THIS MEASUREMENT IS USED FOR MOUNTING THE REAR THREE BRACKETS (ITEM #8).
3. USING THE MEASUREMENTS IN FIG. 3 PLACE THE PREASSEMBLED BRACKETS IN THOSE LOCATIONS AND MARK THEIR LOCATIONS ON THE PINCH WELD.
4. REMOVE THE BRACKET ASSEMBLY AND DRILL THE MARKED LOCATIONS WITH AN 11/32 DRILL BIT.
5. ONCE THE HOLES ARE DRILLED PLACE THE BRACKET ASSEMBLIES BACK IN PLACE AND USE THE 5/16-18 BOLTS, WASHERS, AND NUTS (ITEM #12, 13, &15) TO FASTEN INTO THE PINCH WELD.
6. MAKING SURE THAT VERTICAL BRACKET (ITEM #8) OF THE PREASSEMBLED BRACKETS IS 90 DEGREES WITH THE BODY, USING THE MEASUREMENT TAKEN EARLIER MEASURE THE DISTANCE BETWEEN THE PINCH WELD AND THE HORIZONTAL SURFACE MAKING SURE THAT THE DISTANCE IS THE SAME AS THE EARLIER MEASUREMENT. TIGHTEN UP THE 5/16-18 BOLTS AND FLANGE NUTS (ITEM #14 & 15).
7. MARK ONE OF THE TOP HOLES FOR DRILLING OF THE BRACKET (ITEM #8).
8. REMOVE THE BRACKET ASSEMBLY FROM THE PINCH WELD, AND DRILL THE MARKED HOLE WITH A 3/16 DRILL BIT.
9. REATTACH THE BRACKET ASSEMBLY TO THE PINCH WELD.
10. USING A 5/16 SELF-TAPPING SCREW AND WASHER (ITEM #9 & 11) FASTEN THE TOP OF THE BRACKET TO THE INNER ROCKER PANEL USING THE DRILLED 3/16 HOLE.
11. THE LAST TWO BRACKETS WILL FASTEN THE SAME WAY IN THEIR DESIRED LOCATIONS MENTIONED EARLIER.

PASSANGER SIDE INSTALLATION

1. ATTACHING THE BRACKETS WILL BE THE SAME AS THE DRIVERS SIDE, STEPS 2 THRU 4 ALTHOUGH THE SECOND BRACKET WILL BE ITEM #3.
2. REAR BRACKETS WILL ATTACH THE SAME AS THE DRIVERS SIDE.



SERVICE PARTS LIST

ITEM	PART NO.	QTY	DESCRIPTION
1	552430	2	MTG-BRKT, FRNT, PROMSTR,12 GA, LH/RH, MEGA
1	552405	1	MTG-BRKT, FRNT, PROMSTR,12 GA, LH/RH, GRIP
2	552431	1	MTG-BRKT, MIDDLE LH, MEGA
2	552407	1	MTG-BRKT, MIDDLE LH, GRIP
3	552432	1	MTG-BRKT, MIDDLE RH, MEGA
3	552408	1	MTG-BRKT, MIDDLE RH, GRIP
4	552289	8	RETAINER PLATE, GALV
5	552410	2	RETAINER PLATE, GALV
6	552288	2	SPACER BRACKET, 7 GA, LH/RH
7	552409	6	SPACER BRACKET, 7 GA, LH/RH
8	552433	6	MTG-BRKT, REAR, PROMSTR, 12GA, LH/RH, MEGA
8	552406	6	MTG-BRKT, REAR, PROMSTR, 12GA, LH/RH, GRIP
9	100034	16	WASHER-FL, 5/16, ZP
10	106604	4	NUT-U, MULTI THD, LG, 1/4-20, BLK
11	104267	8	SCR-HWH, TF, AB, SST, 5/16 X .750
12	106997	16	SCR-HHCAP, 5/16-18 X 1.00, SST, BZP
13	106998	16	WASHER-FL, 5/16, BZP
14	100647	12	SCR-HEX HD, 5/16-18 X 1.00 STL, ZP
15	100178	28	NUT-HEX FLG, 5/16-18
16	100006	4	SCR-HEX HD, 1/4-20 X .750, ZP
17	100016	4	WASHER-FL, 1/4, ZP



SERVICE PARTS LIST

BRACKET NO. - 401475

Fig 1.

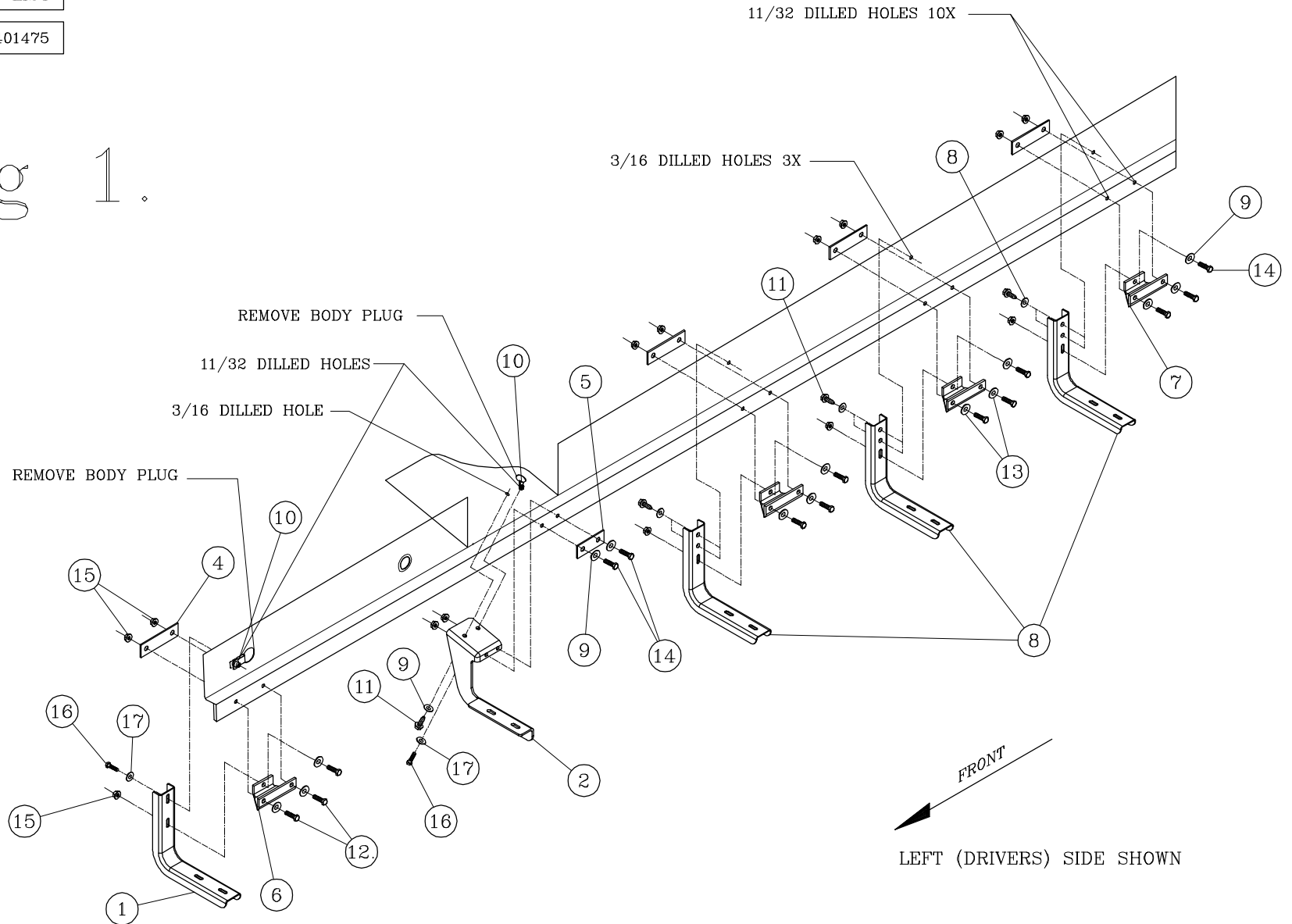

SERVICE PARTS LIST

BRACKET NO. - 401475

Fig. 2

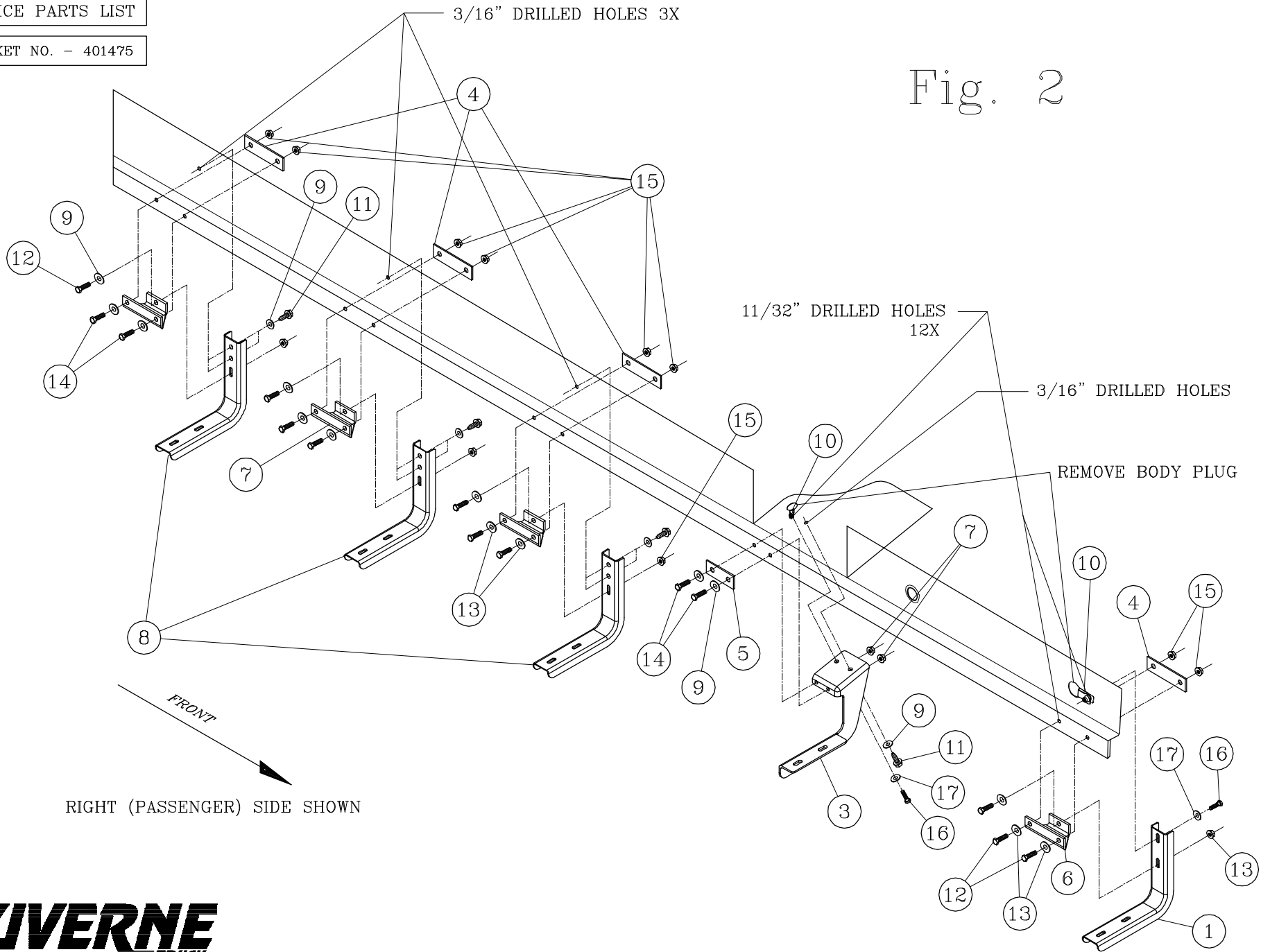

SERVICE PARTS LIST

BRACKET NO. - 401475

DRIVERS SIDE AND PASSANGER SIDE
WILL USE THE SAME DIMENSIONS

Fig 3.

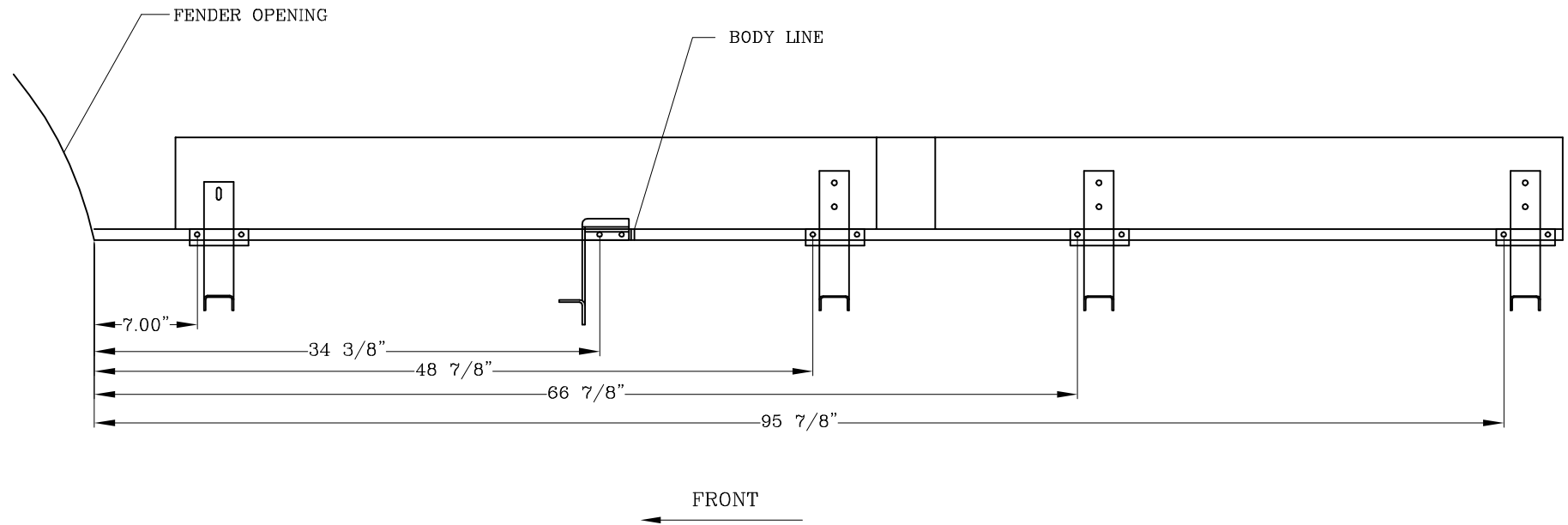

LEFT (DRIVERS) SIDE SHOWN



Choose reliable running boards offered on our website.