

INSTALLATION INSTRUCTIONS AND PARTS LIST

APPLICATION: MODEL 571438W2W MEGA BRACKETS ON:

2014+ RAM 2500 PICKUPS

1. READ INSTRUCTIONS COMPLETELY AND CHECK TO MAKE SURE THAT ALL REQUIRED PARTS (LISTED ON THE SERVICE PARTS LIST) ARE ON HAND BEFORE STARTING THE INSTALLATION.

2. ATTACH THE MOUNTING BRACKETS TO THE VEHICLE AS FOLLOWS:

RAM TRUCKS WITH THREADED INSERTS IN THE ROCKER PANEL.

- 2.1 PLACE THE DRIVERS SIDE FRONT BRACKET (ITEM #1) UP TO THE PINCHWELD SO THAT THE LOWER MOUNTING FLANGE IS TO THE OUTSIDE OF THE PINCHWELD, ALIGN THE TWO RECTANGULAR HOLES OF THE LOWER MOUNTING FLANGE OF (ITEM #1) WITH THE TWO OBOUNDED HOLES IN THE PINCHWELD, INSERT THE TWO 1/4-20 X 1" CARRIAGE BOLTS (ITEM #8) THROUGH THE LOWER MOUNTING FLANGE AND THEN THROUGH THE PINCHWELD, PLACE A 1/4" FLAT WASHER (ITEM #9), AND 1/4-20 FLANGE NUT (ITEM #10) ON TO THE CARRIAGE BOLTS, LEAVE FINGER TIGHT. **SEE FIGURES 1 & 2.**
- 2.2 INSERT AN M8 X 25mm SCREW (ITEM # 11) WITH A 5/16" FLAT WASHER (ITEM #12) THROUGH THE SLOTS ON THE UPPER MOUNTING FLANGE, LEAVE FINGER TIGHT.
- 2.3 REPEAT STEPS 2.1 & 2.2 ON THE MIDDLE (ITEM #2) AND REAR (ITEM #3) BRACKETS.
- 2.4 FOR THE PASSENGER SIDE THE INSTALLATION IS A MIRROR IMAGE OF THE DRIVERS SIDE, USE (ITEM #2) FOR THE FRONT BRACKET, (ITEM #1) FOR THE MIDDLE BRACKET, & (ITEM #4) FOR THE REAR BRACKET.

RAM TRUCKS WITHOUT THREADED INSERTS IN THE ROCKER PANEL.

- 2.5 ON THE VERTICAL WALL OF THE ROCKER PANEL, INSTALL THE T-BOLT WELDMENT (ITEM #14) INTO THE LARGE OBOUNDED HOLE INSERTING THE NUT END FIRST, LEAVING THE THREADED STUD STICKING OUT OF THE OBOUNDED HOLE. **BE CAREFULL NOT TO DROP THE T-BOLT INSIDE OF THE ROCKER PANEL.** ATTACH THE FLAT PLASTIC BOLT RETAINER (ITEM #15) TO THE THREADED STUD OF THE T-BOLT. (THIS IS TO KEEP THE T-BOLT FROM FALLING INTO THE ROCKER PANEL.)
- 2.6 PLACE THE DRIVERS SIDE FRONT BRACKET (ITEM #1) UP TO THE PINCHWELD SO THAT THE LOWER MOUNTING FLANGE IS TO THE OUTSIDE OF THE PINCHWELD, ALIGN THE TWO RECTANGULAR HOLES OF THE LOWER MOUNTING FLANGE OF (ITEM #1) WITH THE TWO OBOUNDED HOLES IN THE PINCHWELD, INSERT THE TWO 1/4-20 X 1" CARRIAGE BOLTS (ITEM #8) THROUGH THE LOWER MOUNTING FLANGE AND THEN THROUGH THE PINCHWELD, PLACE A 1/4" FLAT WASHER (ITEM #9), AND 1/4-20 FLANGE NUT (ITEM #10) ON TO THE CARRIAGE BOLTS, LEAVE FINGER TIGHT. **SEE FIGURES 3 & 4.**
- 2.7 PLACE A FLAT WASHER (ITEM #12), AND AN M8 FLANGE NUT (ITEM #13), ON THE THREADED STUD OF THE T-BOLT (ITEM #14) LEAVE FINGER TIGHT.
- 2.8 ROTATE THE T-BOLT SO THAT THE THREADED NUT IS VISIBLE THROUGH THE SLOTTED HOLE IN THE UPPER MOUNTING FLANGE, INSERT AN M8 X 25mm SCREW (ITEM #11) WITH A 5/16" FLAT WASHER (ITEM #12), LEAVE FINGER TIGHT.
- 2.9 REPEAT STEPS 2.5 THRU 2.8 ON THE MIDDLE (ITEM #2) AND REAR (ITEM #3) BRACKETS.
- 2.10 FOR THE PASSENGER SIDE THE INSTALLATION IS A MIRROR IMAGE OF THE DRIVERS SIDE, USE (ITEM #2) FOR THE FRONT BRACKET, (ITEM #1) FOR THE MIDDLE BRACKET, & (ITEM #4) FOR THE REAR BRACKET.

NOTE: 2009 TO 2012 TRUCKS DO NOT HAVE THE OBOUNDED HOLES IN THE PINCH WELD, THEY WILL REQUIRE DRILLING (2) 5/16" HOLES FOR EACH BRACKET, TO GET THE PROPER LOCATION FOR DRILLING FOLLOW STEP 2.5, AND THEN SKIP TO STEP 2.7 & 2.8, WITH THE BRACKET IN PLACE, NOW MARK THE PINCHWELD FOR DRILLING.



3. ATTACH THE MOUNTING BRACKETS TO THE SHACKLE MOUNT OF THE VEHICLE AS FOLLOWS.
 - 3.1. ATTACH THE UPPER MOUNTING BRACKET (ITEM #5,6) TO THE SIDE OF THE SUSPENSION LINK HOUSING BY LOOSENING THE BOLT THAT FASTENS THE SUSPENSION LINKS TO THE VEHICLE. SLIDE THE UPPER MOUNTING BRACKET (ITEM #5,6) BETWEEN THE BOLT HEAD AND THE FRAME BRACKET. TIGHTEN DOWN THE BOLT MAKING SURE THAT THE UPPER MOUNTING BRACKET (ITEM #5,6) IS LEVEL.
 - 3.2. FASTEN THE LOWER BRACKET (ITEM #7) TO THE UPPER BRACKET (ITEM #5,6) USING 3/8 BOLT, WASHER AND NUT (ITEM #16, 17, 18) USING THE TWO LOWER HOLES IN THE UPPER BRACKET. MAKING SURE THAT IT SITS LEVEL TO THE FRONT BRACKETS.
4. INSTALL THE STEP PLATES, AND ADJUST BRACKETS, AND BOARDS BEFORE TIGHTENING ALL THE FASTENERS.

SERVICE PARTS LIST

ITEM	PART NO.	QTY	DESCRIPTION
1	553006	2	BRKT-MTG, WLDMNT, FRONT LH, MID RH. 571632
2	553007	2	BRKT-MTG, WLDMNT, FRONT RH, MID LH. 571632
3	553008	1	BRKT-MTG, WLDMNT, REAR LH, 571632
4	553009	1	BRKT-MTG, WLDMNT, REAR RH, 571632
5	552457	1	BRKT-MTG, MS, W2W, LH, INBOARD
6	552458	1	BRKT-MTG, MS, W2W, RH, INBOARD
7	551721	2	BRKT-MTG, MS, W2W, LH/RH, LOWER
8	101320	12	BLT-CRG, 1/4-20 X 1.00", SST, BLK, EM6219
9	101370	12	WSHR-FL, SST, .281 X .625 X .065
10	102366	12	NUT-FLG, HEX, 1/4-20, SST
11	102549	12	SCR-HEX HD, M8 X 1.25 X 25mm, ZP
12	100034	12	WSHR-FL, 5/16, ZP
13	105859	6	NUT HEX-FLG, M8 X 1.25, ZP
14	553012	6	T-BOLT WELDMNT, ZP, 571632
15	101572	6	BOLT RETAINER-PLASTIC, 8mm
16	100040	4	SCR-HEX HD, 3/8-16 X 1.0" UNC, ZP
17	100062	4	WSHR, FLAT, 3/8", .438 ID X 1.00 OD X .083" THK
18	100181	4	NUT, SERR FLG, HEX, 3/8-16 UNC, ZP



SERVICE PARTS LIST

BRACKET NO. - 571428

Fig.1

INSTALLATION ON ROCKER PANELS WITH THREADED INSERTS

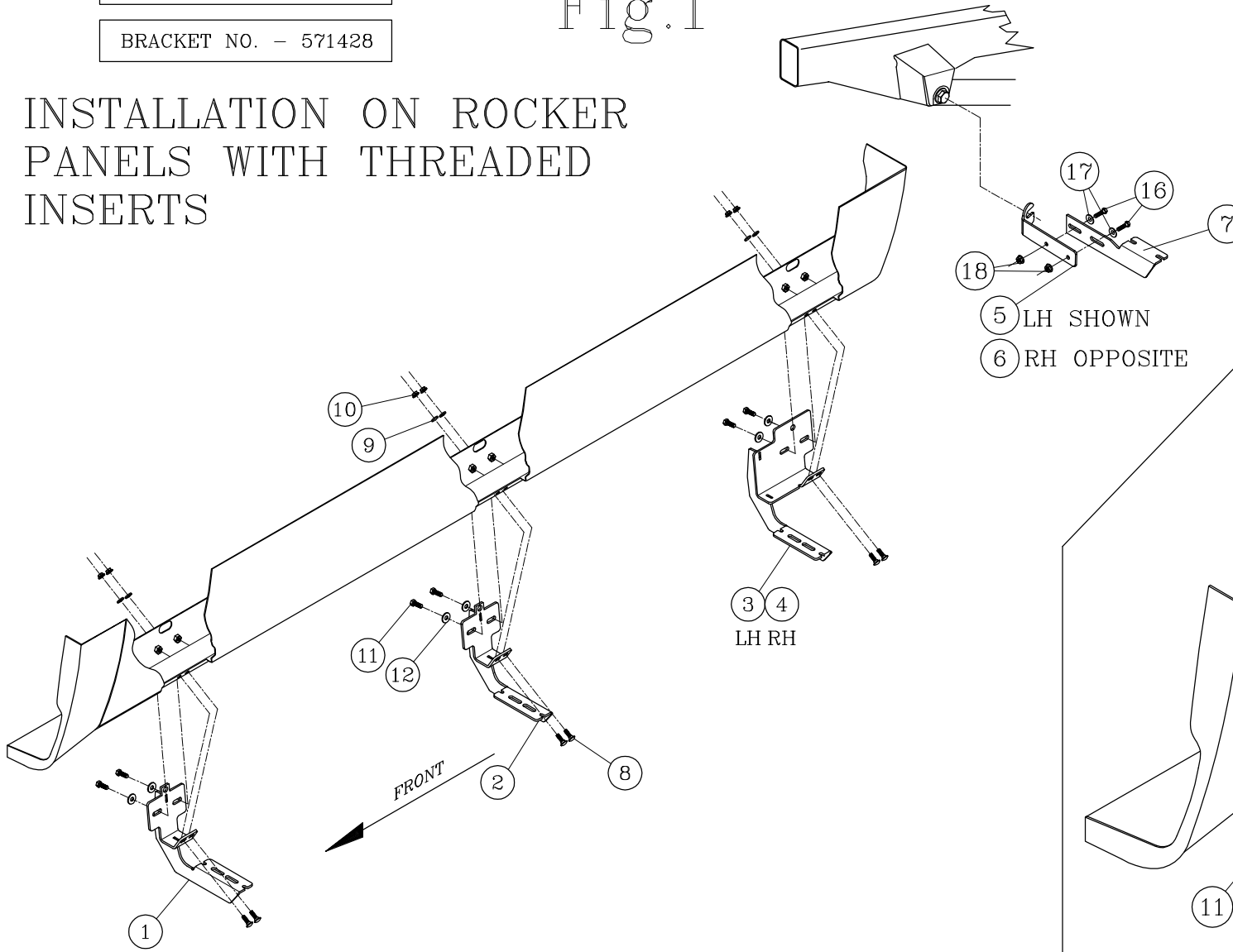

3 4
LH RH

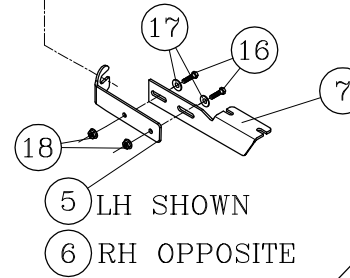

Fig.2

LEFT (DRIVER) SIDE SHOWN
-RIGHT (PASSENGER) SIDE OPPOSITE-



SERVICE PARTS LIST

BRACKET NO. - 571438

Fig.3

INSTALLATION ON ROCKER PANELS WITHOUT THREADED INSERTS

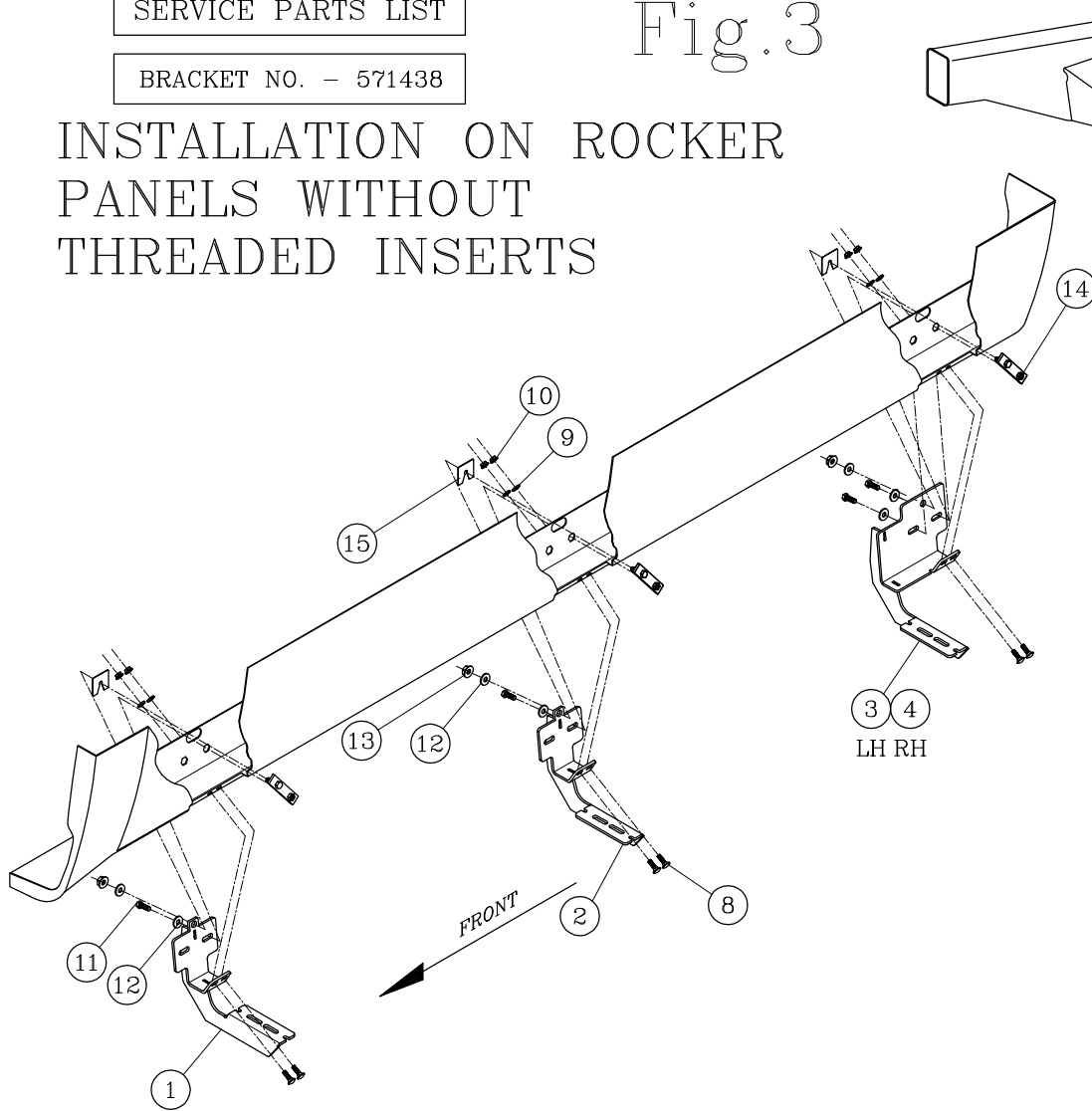

LEFT (DRIVER) SIDE SHOWN
-RIGHT (PASSENGER) SIDE OPPOSITE-

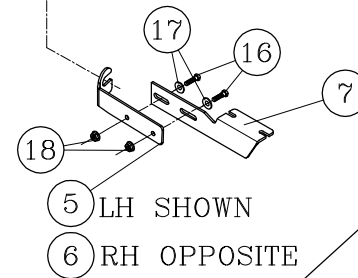
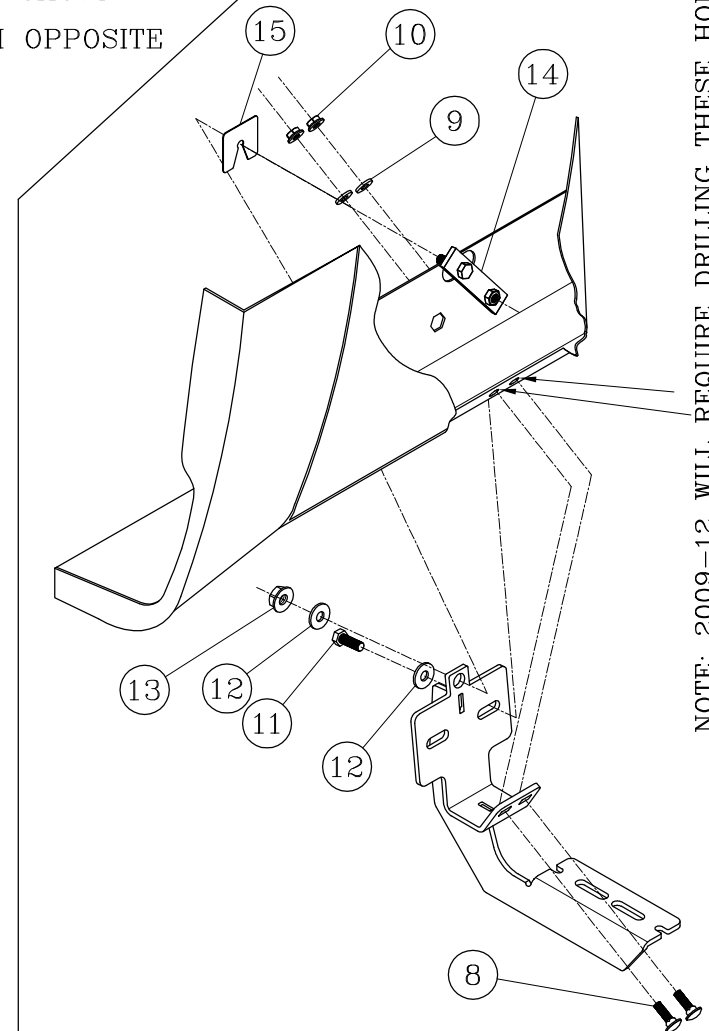

Fig.4



NOTE: 2009-12 WILL REQUIRE DRILLING THESE HOLES IN THE PINCHWELD.

Choose reliable running boards offered on our website.