

# INSTALLATION MANUAL

# 570747

## Level of Difficulty

Moderate

Installation difficulty levels are based on time and effort involved and may vary depending on the installer level of expertise, condition of the vehicle and proper tools and equipment.

**This is the first of two manuals required to complete this installation. The second manual is included with your side steps / running boards.**

## Parts List

Item	Qty	Description
1	2	Mounting bracket, driver side
2	2	Mounting bracket, passenger side front
3	3	Mounting bracket, passenger side rear
4	2	Mounting bracket, spacer
5	7	Retainer plate
6	17	Flat washer, 5/16"
7	17	Hex bolt, 5/16"-18 x 1", grade 5
8	16	Flange nut, 5/16"-18
9	4	Flat washer, 5/16", black zinc plate
10	4	Hex bolt, 5/16"-18 x 1", grade 5, black zinc plate
11	5	Clip on nut, 5/16"-18
12	4	Thread forming bolt, 5/16" x 1"

## Tools Required

Drill	Ratchet
Drill bit, 7/16"	Wrench, 1/2"
Drill bit, 7/32"	Straight edge or Level
Drill bit, 11/32"	Paint marker
Socket, 1/2"	Tape measure
Panel trim removal tool	--

## Torque Specifications

5/16" 7 ft-lbs.

Use above torque setting unless otherwise noted

## Product Photo

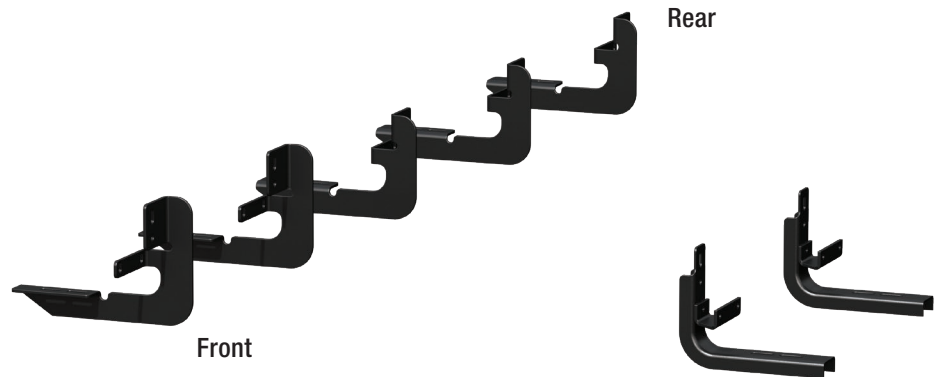

## NOTICE

Before you begin installation, read all instructions thoroughly.

Proper tools will improve the quality of installation and reduce the time required.

Periodic inspection of your product should be performed to ensure all hardware and / or components remain secure.

To help prevent damage to the product or vehicle, refer to the specified torque specifications when securing hardware during the installation process.

## Maintenance

Mild automotive detergent may be used to clean the product. Do not use dish detergent, abrasive cleaners, abrasive pads, wire brushes or other similar products that may damage the finish.

# DRIVER SIDE INSTALLATION

## Step 1

Pre-assemble both driver side brackets with spacer brackets, using the 5/16"-18 hex bolts with 5/16" washers and 5/16"-18 flange nut.

Snug the hardware, but do not fully tighten.

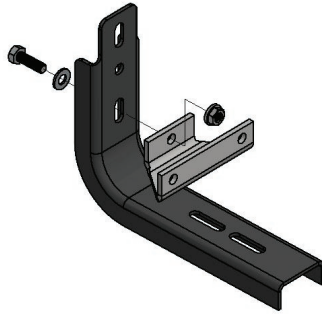

## Step 2

On the back side of the rocker panel, measure about 9-1/2" back from the front of the mud flap. There should be a body plug in this location. If the van does not have rear A/C, scrape the under coating off around the body plug and remove the plug.

## Step 3A

After the body plug is removed, drill a 7/16" hole 1/2" to the front of the body plug hole and insert the 5/16"-18 U-Nut.

Place a driver-side bracket in place using the top slot and fasten using the 5/16"-18 bolt and washer.

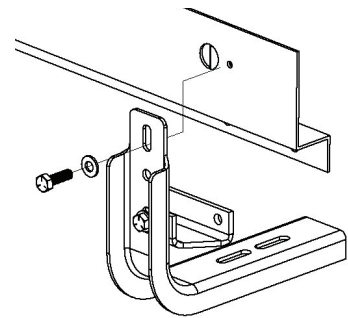
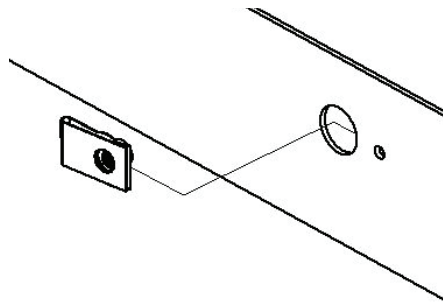

## Step 3B

If the van does have rear A/C, you will not need to remove the body plug. Instead place the pre-assembled bracket into place and mark the hole location using the center round hole in the bracket as a guide. Make sure that the bracket is level with the truck.

Remove the bracket and center punch the marked hole. Drill a 7/32" hole. Place the bracket back in place and install the 5/16" self-tapping screw.

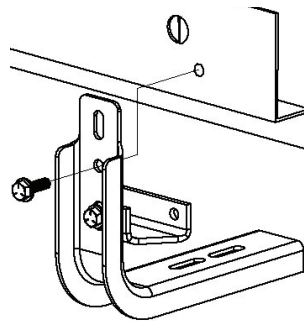

## Step 4

Once the bracket is in place, the lower mount is ready to be drilled. Use an 11/32" drill bit to drill two holes using the two holes in the lower bracket mount as a guide.

Adjust the lower bracket if needed to ensure the two holes are fully on the pinch seam.

### Step 5

After the drilling is complete, fasten the bracket to the pinch seam using the supplied black 5/16"-18 bolts and 5/16" washers through the drilled holes. On the back side of the pinch weld, place the retainer plate over the bolts and fasten them with the 5/16"-18 flange nuts.

Tighten down all fasteners.

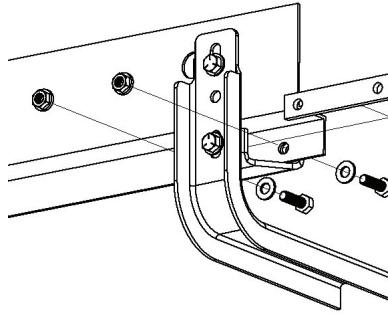

### Step 6

For the second driver side bracket, on the back side of the rocker panel, measure about 27-1/2" back from the front of the mud flap and mark the location. This is approximately where the second bracket will be installed.

Also measure the height of the first bracket from the top of the bracket to the bottom of the floor board and mark that location for the second bracket. This will assist with mounting the board level.

### Step 7

Using the bracket as a guide, mark the top mounting hole using the top slot in the bracket. Center punch and drill a 7/32" hole.

Secure the bracket using a 5/16" self-tapping screw.

Snug the hardware, but do not fully tighten.

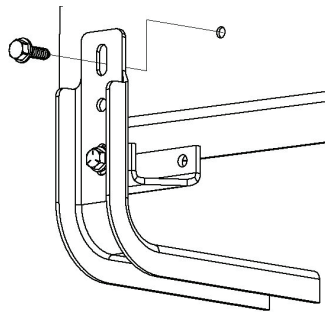

### Step 8

Once the bracket is in place, the lower mount is ready to be drilled. Use an 11/32" drill bit to drill two holes using the two holes in the lower bracket mount as a guide.

Adjust the lower bracket if needed to ensure the two holes are fully on the pinch seam.

### Step 9

Once the drilling is complete, fasten the bracket to the pinch seam using the supplied black 5/16"-18 bolts and 5/16" washers through the drilled holes. On the back side of the pinch weld place the retainer plate over the bolts and fasten them with the 5/16"-18 flange nuts.

Tighten down all fasteners.

# PASSENGER SIDE

## Step 1

On the back side of the rocker panel, measure about 9-1/2" back from the front of the mud flap. There should be a body plug in this location. If the van does not have rear A/C, scrape the under coating off around the body plug and remove the plug.

## Step 2A

After the body plug is removed, drill a 7/16" hole 1/2" to the front of the body plug hole and insert the 5/16"-18 U-Nut.

Place a passenger-side bracket in place using the top slot and fasten using the 5/16"-18 bolt and washer.

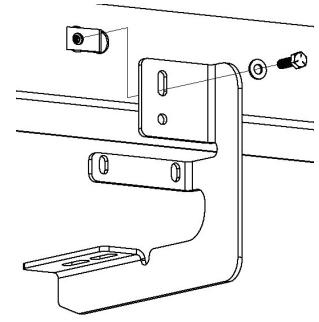
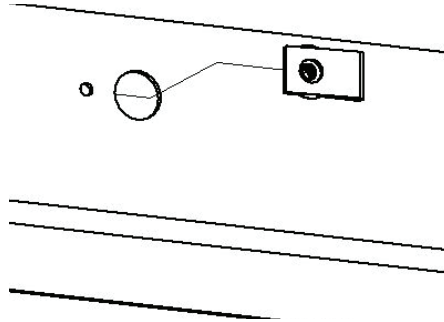

## Step 2B

If the van does have rear A/C, you will not need to remove the body plug. Instead place the pre-assembled bracket into place and mark the hole location using the center round hole in the bracket as a guide. Make sure that the bracket is level with the truck.

Remove the bracket and center punch the marked hole. Drill a 7/32" hole. Place the bracket back in place and install the 5/16" self-tapping screw.

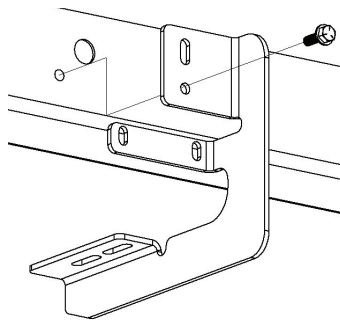

## Step 3

Once the bracket is in place, the lower mount is ready to be drilled. Use an 11/32" drill bit to drill two holes using the two holes in the lower bracket mount as a guide.

Adjust the lower bracket if needed to ensure the two holes are fully on the pinch seam.

## Step 4

After the drilling is complete, fasten the bracket to the pinch seam using the supplied black 5/16"-18 bolts and 5/16" washers through the drilled holes. On the back side of the pinch weld, place the retainer plate over the bolts and fasten them with the 5/16"-18 flange nuts.

Tighten down all fasteners.

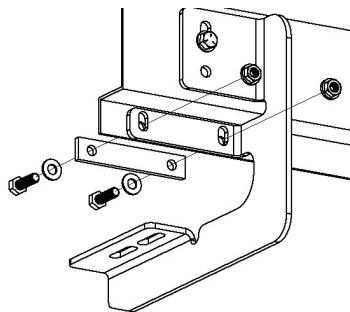

### Step 5

For the second passenger side bracket, on the back side of the rocker panel, measure about 27-1/2" back from the front of the mud flap and mark the location. This is approximately where the second bracket will be installed.

Also measure the height of the first bracket from the top of the bracket to the bottom of the floor board and mark that location for the second bracket. This will assist with mounting the board level.

### Step 6

Using the bracket as a guide, mark the top mounting hole using the top slot in the bracket. Center punch and drill a 7/32" hole.

Secure the bracket using a 5/16" self-tapping screw.

Snug the hardware, but do not fully tighten.

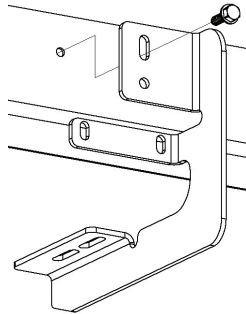

### Step 7

Once the bracket is in place, the lower mount is ready to be drilled. Use an 11/32" drill bit to drill two holes using the two holes in the lower bracket mount as a guide.

Adjust the lower bracket if needed to ensure the two holes are fully on the pinch seam.

### Step 8

Once the drilling is complete, fasten the bracket to the pinch seam using the supplied zinc 5/16"-18 bolts and 5/16" washers through the retainer plate and drilled holes. Secure with the 5/16"-18 flange nuts.

Tighten down all fasteners.

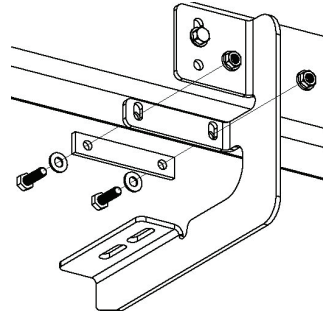

### Step 9

For the third passenger-side bracket, on the back side of the rocker panel, measure about 48-1/2" back from the front of the mud flap. In this location there should be a body plug.

Scrape away the under coating and remove the body plug. Measure back 1/2" from the opening and drill a 7/16" hole and insert the 5/16"-18 U-Nut.

Place the rear passenger-side bracket in place, using the top slot in the bracket. Fasten with the supplied 5/16"-18 bolt and 5/16" washer.

Snug the hardware, but do not fully tighten.

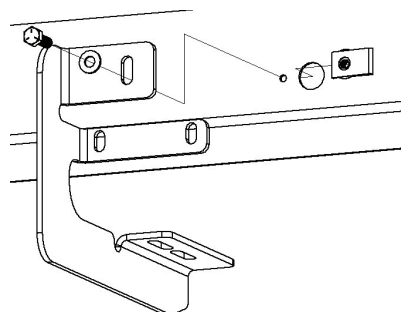

### Step 10

Once the bracket is in place, the lower mount is ready to be drilled. Use an 11/32" drill bit to drill two holes using the two holes in the lower bracket mount as a guide.

Adjust the lower bracket if needed to ensure the two holes are fully on the pinch seam.

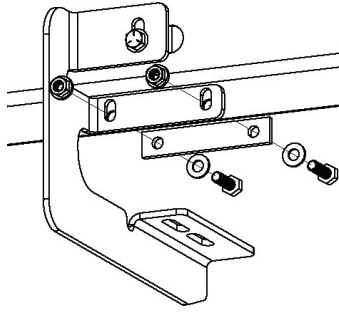

### Step 11

Repeat step 9 and 10 measuring back 68-1/2" and 88-1/2" for the remaining passenger-side brackets. There will be body plugs in these locations to install the final 2 brackets.

Use a straight edge or level to adjust brackets and tighten all fasteners.

**Note:** To complete the installation, refer to the manual included with your running boards / side steps.