

INSTALLATION INSTRUCTIONS AND PARTS LIST

MODEL 570344 MEGA STEPS

VEHICLE APPLICATION:

2003 AND NEWER 135" WB CHEVROLET EXPRESS AND GMC SAVANA VANS

READ INSTRUCTIONS COMPLETELY AND CHECK TO MAKE SURE THAT ALL REQUIRED PARTS (LISTED ON SERVICE PARTS LIST) ARE ON HAND BEFORE STARTING THE INSTALLATION

1. ON THE LEFT SIDE OF THE VEHICLE, REMOVE THE FRONT BODY MOUNTING BOLT. THE BOLT, STEEL WASHER AND RUBBER CUSHION WILL BE REUSED.
2. INSTALL THE MULTI-THREAD U-NUT (ITEM #10) ON THE FRONT MOUNTING BRACKET (ITEM #3). **(NOTE: INSTALL IN THE TOP HOLE FOR 1500 VANS. INSTALL IN THE BOTTOM HOLE FOR 2500 & 3500 VANS.)**
3. INSTALL THE FRONT MOUNTING BRACKET (ITEM #3) TO THE FRONT BODY MOUNT WITH THE WASHER AND THE RUBBER CUSHION BETWEEN THE MOUNTING BRACKET AND THE BODY MOUNT. THE STEP END OF THE BRACKET SHOULD BE PERPENDICULAR TO THE OUTSIDE BODY. TIGHTEN THE BOLT TO 65 LB. FT.
4. INSTALL A 3/8"-16 SERRATED FLANGE NUT (ITEM #9) ON THE 3/8"-16 X 5" HEX BOLT (ITEM #7) WITH THE FLANGE FACING TOWARD THE END OF THE BOLT AND TURN ON JUST SHORT OF THE HEAD. SCREW THE BOLT INTO THE U-NUT AND WHEN IT COMES THROUGH THE OTHER SIDE START ANOTHER FLANGE NUT FACING THE AS THE FIRST NUT. TURN THE NUT ON UNTIL THERE IS 3/4" PROTRUDING FROM THE FACE OF THE NUT, INSTALL A 3/8" FLAT WASHER (ITEM #12) AND THE .354 X 1.00 X .748 RUBBER WASHER (ITEM #14) INTO THE END OF THE BOLT. ADJUST THE LOAD REACTION BOLT ASSEMBLY SO THAT THE RUBBER CUSHION IS SNUG AGAINST THE FRAME AND TIGHTEN DOWN THE OUTSIDE FLANGE NUT. **(LOAD REACTION BOLT ASSEMBLY)** AS SHOWN IN *fig. 1*.
5. REMOVE THE SECOND BODY MOUNTING BOLT. THE BOLT, STEEL WASHER AND RUBBER CUSHION WILL BE REUSED.
6. INSTALL THE MULTI-THREAD U-NUT (ITEM #10) ON THE SECOND MOUNTING BRACKET (ITEM #5). INSTALL A .364 X .625 CAP PLUG (ITEM #13) ONTO THE END OF THE "U" NUT. **(NOTE: INSTALL IN THE TOP HOLE FOR 1500 VANS. INSTALL IN THE BOTTOM HOLE FOR 2500 & 3500 VANS.)**
7. INSTALL THE SECOND MOUNTING BRACKET (ITEM #5) TO THE SECOND BODY MOUNT WITH THE WASHER AND THE RUBBER CUSHION BETWEEN THE MOUNTING BRACKET AND THE BODY MOUNT. THE STEP END OF THE BRACKET SHOULD BE PERPENDICULAR TO THE OUTSIDE BODY. TIGHTEN THE BOLT TO 65 LB. FT.
8. INSTALL A 3/8"-16 SERRATED FLANGE NUT (ITEM #9) ON THE 3/8"-16 X 1-3/4" HEX BOLT (ITEM #8) WITH THE FLANGE FACING TOWARD THE END OF THE BOLT AND TURN ON JUST SHORT OF THE HEAD. SCREW THE BOLT INTO THE U-NUT AND WHEN IT COMES THROUGH THE OTHER SIDE ADJUST THE LOAD REACTION BOLT ASSEMBLY SO THAT THE RUBBER PLUG IS SNUG AGAINST THE FRAME AND TIGHTEN DOWN THE OUTSIDE FLANGE NUT. **(LOAD REACTION BOLT ASSEMBLY)** AS SHOWN IN *fig. 1*.



(A LUVERNE Company)

9. ON THE RIGHT SIDE OF THE VEHICLE, REMOVE THE FRONT BODY MOUNTING BOLT. THE BOLT, STEEL WASHER AND RUBBER CUSHION WILL BE REUSED.
10. INSTALL THE MULTI-THREAD U-NUT (ITEM #10) ON THE FRONT MOUNTING BRACKET (ITEM #4). **(NOTE: INSTALL IN THE TOP HOLE FOR 1500 VANS. INSTALL IN THE BOTTOM HOLE FOR 2500 & 3500 VANS.)**
11. INSTALL THE FRONT MOUNTING BRACKET (ITEM #4) TO THE FRONT BODY MOUNT WITH THE WASHER AND THE RUBBER CUSHION BETWEEN THE MOUNTING BRACKET AND THE BODY MOUNT. THE STEP END OF THE BRACKET SHOULD BE PERPENDICULAR TO THE OUTSIDE BODY. TIGHTEN THE BOLT TO 65 LB. FT
12. INSTALL A 3/8"-16 SERRATED FLANGE NUT (ITEM #9) ON THE 3/8"-16 X 5" HEX BOLT (ITEM #7) WITH THE FLANGE FACING TOWARD THE END OF THE BOLT AND TURN ON JUST SHORT OF THE HEAD. SCREW THE BOLT INTO THE U-NUT AND WHEN IT COMES THROUGH THE OTHER SIDE START ANOTHER FLANGE NUT FACING THE AS THE FIRST NUT. TURN THE NUT ON UNTIL THERE IS 3/4" PROTRUDING FROM THE FACE OF THE NUT, INSTALL A 3/8" FLAT WASHER (ITEM #12) AND THE .364 X 1.00 X .748 RUBBER WASHER (ITEM #14) INTO THE END OF THE BOLT. ADJUST THE LOAD REACTION BOLT ASSEMBLY SO THAT THE RUBBER CUSHION IS SNUG AGAINST THE FRAME AND TIGHTEN DOWN THE OUTSIDE FLANGE NUT. **(LOAD REACTION BOLT ASSEMBLY)** AS SHOWN IN *fig. 1*.
13. REMOVE THE SECOND BODY MOUNTING BOLT. THE BOLT, STEEL WASHER AND RUBBER CUSHION WILL BE REUSED.
14. INSTALL THE MULTI-THREAD U-NUT (ITEM #10) ON THE SECOND MOUNTING BRACKET (ITEM #5). INSTALL A .364 X .625 CAP PLUG (ITEM #13) ONTO THE END OF THE "U" NUT. **(NOTE: INSTALL IN THE TOP HOLE FOR 1500 VANS. INSTALL IN THE BOTTOM HOLE FOR 2500 & 3500 VANS.)**
15. INSTALL THE SECOND MOUNTING BRACKET (ITEM #5) TO THE SECOND BODY MOUNT WITH THE WASHER AND THE RUBBER CUSHION BETWEEN THE MOUNTING BRACKET AND THE BODY MOUNT. THE STEP END OF THE BRACKET SHOULD BE PERPENDICULAR TO THE OUTSIDE BODY. TIGHTEN THE BOLT TO 65 LB. FT.
16. INSTALL A 3/8"-16 SERRATED FLANGE NUT (ITEM #9) ON THE 3/8"-16 X 1-3/4" HEX BOLT (ITEM #8) WITH THE FLANGE FACING TOWARD THE END OF THE BOLT AND TURN ON JUST SHORT OF THE HEAD. SCREW THE BOLT INTO THE U-NUT AND WHEN IT COMES THROUGH THE OTHER SIDE ADJUST THE LOAD REACTION BOLT ASSEMBLY SO THAT THE RUBBER PLUG IS SNUG AGAINST THE FRAME AND TIGHTEN DOWN THE OUTSIDE FLANGE NUT. **(LOAD REACTION BOLT ASSEMBLY)** AS SHOWN IN *fig. 1*.
17. AFTER MOUNTING THE 4th AND 5th BRACKET, MEASURE FROM THE BOTTOM OF THE BODY FLANGE DOWN TO THE BOTTOM OF THE MOUNTING BRACKETS TO MAKE SURE THEY ARE THE SAME, AND WHEN INSTALLING THE 6th BRACKET ADJUST IT TO THIS DIMENSION BEFORE TIGHTENING THE BOLTS.
18. REMOVE THE NUT AND WASHER FROM THE FRONT SPRING SHACKLE BOLT. SAVE THE NUT TO BE REUSED. INSTALL THE BLACK SPACER WASHER (ITEM #15), MOUNTING BRACKET (ITEM #6), 5/8" FLAT WASHER (ITEM #11) AND THE FACTORY NUT ONTO THE SPRING SHACKLE BOLT. ADJUST THE HEIGHT AND TIGHTEN TO 65 LB. FT.



(A LIVERNE Company)

19. INSTALL FOUR SQUARE HEAD SCREWS, 5/16"-18 X 1" (ITEM #16) IN THE FRONT TRACK OF THE STEP PLATES.
20. POSITION THE MEGA STEPS ON THE MOUNTING BRACKETS SO THAT THE SQUARE HEAD SCREWS ARE LOCATED IN THE SLOTS OF THE MOUNTING BRACKETS AND THE STEP IS CENTERED, FRONT TO REAR, ON THE VEHICLE. INSTALL 5/16" SERRATED FLANGE NUTS (ITEM #17) ON THE SQUARE HEAD SCREWS. FINGER TIGHTEN ONLY AT THIS TIME.
21. ALIGN THE STEP PLATE WITH THE BOTTOM OF THE BODY SHEET METAL. THE TOP OF THE STEP SHOULD BE APPROXAMATELY 2-1/2" FROM THE BOTTOM OF THE BODY PANEL.
22. TIGHTEN THE STEP PLATE BOLTS TO 19 FOOT POUNDS OF TORQUE.

SERVICE PARTS LIST

ITEM	PART NO.	QTY	DESCRIPTION
1	575100-36	1	STEP ASSY- 36.00" (MOD. 575100)
2	575100-98	1	STEP ASSY- 98.00" (MOD. 575100)
3	552100	1	MOUNTING BRACKET – LH, FRONT
4	552101	1	MOUNTING BRACKET – RH, FRONT
5	552264	2	MOUNTING BRACKET – CENTER, RH
6	552107	1	MOUNTING BRACKET – REAR, RH
7	104673	2	SCREW – HEX HEAD CAP, 3/8"-16 X 5", FULL THREAD, ZP
8	107211	2	SCREW – HEX WASHER HEAD, 3/8"-16 X 1-3/4", ZP
9	100181	6	NUT – SERRATED FLANGE, 3/8"-16, ZP
10	109258	4	U-NUT – MULTI THREAD, 3/8"-16 X 1.09"
11	100147	1	FLAT WASHER - 5/8", ZP
12	106962	2	FLAT WASHER – 3/8", SST, BZP
13	103325	2	CAP PLUG - .364 X .625, VINYL, BLACK
14	102592	2	RUBBER WASHER - .354 X 1.00 X .748
15	552109	1	SPACER WASHER – 1/8" x 1-3/4"
16	106880	16	BOLT - SQUARE HEAD, 5/16"-18 X 1", ZP (INCLUDED IN STEP)
17	102680	16	NUT – HEX FLANGE, 5/16"-18 (INCLUDED IN STEP)



(A LIVERNE Company)

SERVICE PARTS LIST

MODEL NO. - 570344

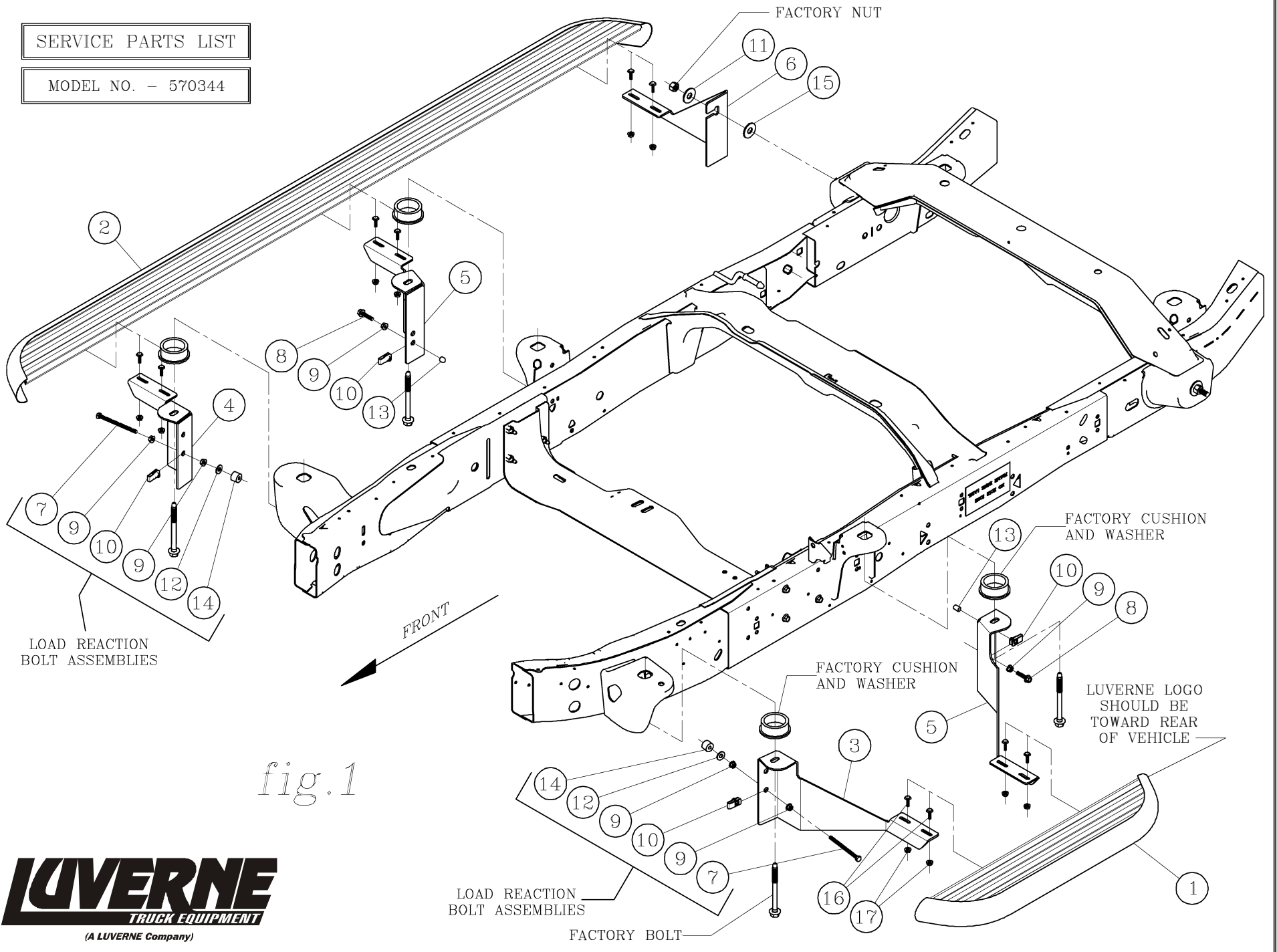

Get in and out of your truck or SUV easier with running boards available on our website.