

# INSTALLATION INSTRUCTIONS AND PARTS LIST

## MODEL 570922 MEGA STEPS BRACKETS:

2009 AND NEWER FORD F-150 SUPER CAB AND SUPERCREW PICKUPS



1. READ INSTRUCTIONS COMPLETELY AND CHECK TO MAKE SURE THAT ALL REQUIRED PARTS (LISTED ON SERVICE PARTS LIST) ARE ON HAND BEFORE STARTING THE INSTALLATION.
2. EXISTING MOUNTING HOLE PATTERNS ARE LOCATED ON THE PINCH WELD AND INTERIOR WALL OF THE ROCKER PANEL. THESE MOUNTING HOLE PATTERNS MUST BE USED FOR THIS INSTALLATION PER THE FOLLOWING INSTRUCTIONS.
  - 2.1. INSTALL 5/16" MULTI THREAD U-NUTS (ITEM #5) IN THE TOP REAR HOLES OF THE FRONT AND CENTER PATTERNS AND IN THE TOP FRONT HOLE OF THE REAR PATTERN AS SHOWN. INSTALL THESE U-NUTS SO THAT THE THREADS ARE TO THE INSIDE OF THE ROCKER PANEL. (THIS IS DONE BY INSERTING THE THREADED HALF OF THE U-NUT THRU THE LARGE ACCESS HOLES AND SLIDING THE U-NUT TOWARDS THE ROUND HOLE UNTIL IT SEATS IN THE ROUND HOLE).

### **SUPER CAB**

3. ATTACH THE MOUNTING BRACKETS (ITEM #2) TO THE VEHICLE.
  - 3.1. POSITION THE (3) BRACKETS ON THE VEHICLE SO THAT THE TOP HOLE LINES UP WITH THE MULTI THREAD U-NUT AND THE HOLE IN THE OFFSET LINES UP WITH THE HOLE IN THE PINCH WELD. ATTACH THE TOP OF THE BRACKET WITH A 5/16" X 1.00" ZINC PLATED HEX HEAD CAP SCREW (ITEM #6) AND 5/16" ZINC PLATED FLAT WASHER (ITEM #7). ATTACH THE BOTTOM OF THE BRACKET TO THE PINCH WELD WITH A 5/16" X 1.00" BLACK PLATED HEX HEAD CAP SCREW (ITEM #8), 5/16" BLACK PLATED FLAT WASHER (ITEM #9) AND 5/16" SERRATED FLANGE NUT (ITEM #4). LEVEL THE BRACKETS AND TIGHTEN THE FASTENERS TO 19 LB FT.

### **SUPER CREW ONLY**

4. ATTACH THE MIDDLE MOUNTING BRACKET (ITEM #2) TO THE VEHICLE
  - 4.1 ATTACH ANGLE BRACKET (ITEM #10) TO MOUNTING BRACKET (ITEM #2) WITH A 5/16" X 1.00" ZINC PLATED HEX HEAD CAP SCREW (ITEM #6) AND 5/16" ZINC PLATED FLAT WASHER (ITEM #7). AND A 5/16" SERRATED FLANGE NUT (ITEM #4) TOGETHER WITH THE ANGLE TOWARDS THE MULTI THREAD U-NUT IN THE HOLE THAT IS OFFSET FROM THE PINCH WELD HOLE . REPEAT STEP 3.1 USING ANGLE BRKT.
5. ATTACH THE STEP (ITEM #1) TO THE MOUNTING BRACKETS.
  - 5.1. INSERT THREE (3) 5/16" SQUARE HEAD SCREWS (ITEM #3) IN THE CENTER SLOT ON THE UNDER SIDE OF THE STEP.
  - 5.2. POSITION THE STEP ON THE MOUNTING BRACKETS SO THAT THE SQUARE HEAD SCREWS ARE LOCATED IN THE SLOTS OF THE MOUNTING BRACKETS AND THE STEP IS CENTERED, FRONT TO REAR, ON THE CAB.
  - 5.3. LOCATE THE STEP, IN AND OUT, AS DESIRED, INSTALL 5/16" SERRATED FLANGE NUTS (ITEM #4) ON THE SQUARE HEAD SCREWS AND TIGHTEN TO 19 LB FT.
  - 5.4. INSTALL 5/16-18 SERRATED FLANGE NUTS (ITEM #4) ON ANY UNUSED SQUARE HEAD SCREWS IN THE INBOARD SLOT OF THE STEP AND TIGHTEN TO 19 LB FT.

## SERVICE PARTS LIST

ITEM	PART NO.	QTY	DESCRIPTION
1		2	MEGA STEP BOARD ASSEMBLY (SOLD SEPARATELY) LENGTH WILL VARY DEPENDING ON APPLICATION
2	551560	6	BRKT- MTG, STEP, F-150 PICKUP
3	106880	6	SCREW-SQUARE HEAD, 5/16_18 UNC
4	102680	22	NUT-SERRATED FLANGE, HEX, SST, 5/16-18 UNC
5	104264	6	U-NUT- MULTI THREAD, 5/16-18 UNC, STL, BLK
6	100647	8	SCREW- HEX HEAD CAP, 5/16_18 UNC X 1.00".ZP
7	100034	8	WSHR-PL, A, STL, 5/16,.375 ID X .875 OD X .083 THK, ZP
8	106997	6	SCREW- HEX HEAD CAP, 5/16_18 UNC X 1.00", SST, BZP
9	106998	6	WSHR-PL, A, SST, 5/16,.375 ID X .875 OD X .083 THK, BZP
10	551559	2	BRKT-MTG,ANGLE, 09 F-150

SERVICE PARTS LIST

BRACKET NO. - 570922

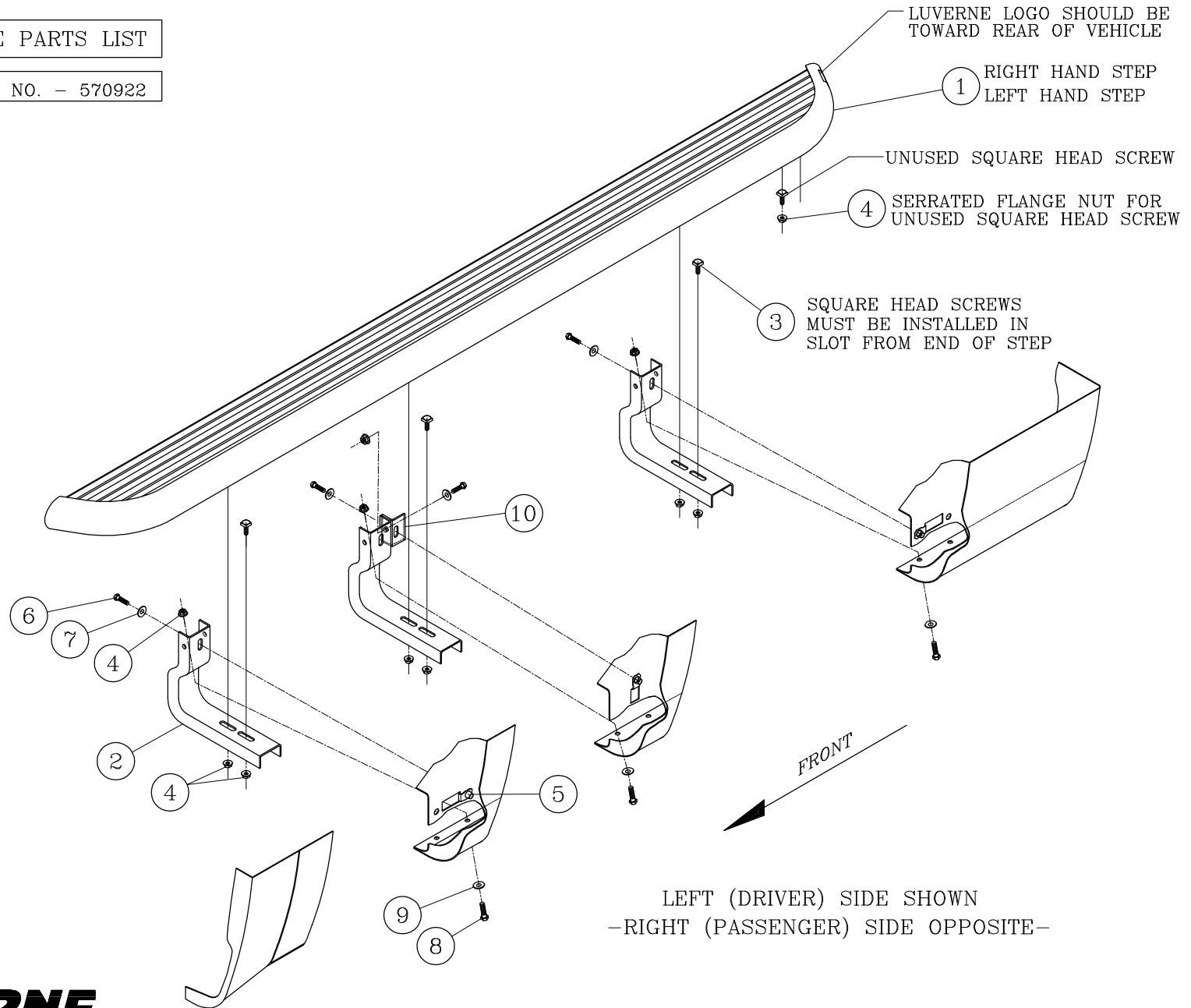

LEFT (DRIVER) SIDE SHOWN  
-RIGHT (PASSENGER) SIDE OPPOSITE-

**LUERNE**  
TRUCK  
EQUIPMENT  
INC.

Choose reliable running boards offered on our website.