

INSTALLATION INSTRUCTIONS AND PARTS LIST

APPLICATION: MODEL 571117 W2W MEGA STEP BRACKETS:
2011 AND NEWER 1500/2500/3500 SERIES CHEVROLET AND GMC
REGULAR, EXTENDED, AND CREW CAB PICKUPS



1. READ INSTRUCTIONS COMPLETELY AND CHECK TO MAKE SURE THAT ALL REQUIRED PARTS (LISTED ON THE SERVICE PARTS LIST) ARE ON HAND BEFORE STARTING THE INSTALLATION.
2. ASSEMBLE THE LOAD REACTION STUDS AND HARDWARE (ITEM#13 THRU #16) AS FOLLOWS:
 - 2.1 ON THE SHORT THREADED END OF THE LOAD REACTION STUD (ITEM #16), INSTALL A BLACK 3/8" SERRATED FLANGE NUT (ITEM #15) BACKWARDS TO THE BOTTOM OF THE THREAD. THEN, INSTALL A BLACK 3/8" FLAT WASHER (ITEM #14) AND RUBBER "CUSHION" WASHER (ITEM #13) TIGHT UP AGAINST THE SERRATED FLANGE NUT. (THE END OF THE STUD MUST BE RECESSED IN THE RUBBER WASHER, APPROX 3/16").
 - 2.2 ON THE LONG THREADED END OF THE STUD, INSTALL A BLACK 3/8" SERRATED FLANGE NUT (ITEM #15) BACKWARDS TO NEAR TO THE BOTTOM OF THE THREADS.
3. ATTACH THE LOAD REACTION STUD ASSEMBLIES TO THE BODY MOUNTING BRACKETS AS SHOWN.

NOTE: IF YOU ARE MOUNTING THE STEPS ON A 1500 MODEL PICKUP, YOU MUST ATTACH BRACKET 551571 (#23) TO BRACKETS 551902 (#2 & 3) (SEE FIG 1,2, OR 3) IN ORDER TO USE THE LOAD REACTION STUD.

- 3.1. INSERT THE STUD, FROM WHAT WILL BE IN THE INBOARD OR FRAME SIDE THRU THE LOWEST HOLE IN THE BENT FLANGE OF THE BODY BRACKETS THAT WILL ALLOW THE RUBBER WASHER TO SEAT FIRM AGAINST THE SIDE WALL OF THE FRAME. INSTALL A BLACK FLANGE NUT (ITEM #15) ON THE OUTBOARD END OF THE STUD (FINGER TIGHT ONLY).

NOTE:

DUE TO EXCESSIVE THREAD LOCKER IN THE BODY MOUNT BOLT AREA ON THE 2010+ GM SILVERADO/SIERRA, USE CAUTION WHEN REMOVING THE BODY MOUNT BOLTS TO REDUCE THE RISK OF CAUSING DAMAGE TO THE THREADED INSERTS INSIDE THE VEHICLE.

4. REMOVE THE FACTORY FRONT, CENTER, AND REAR BODY MOUNT BOLTS (ONE SIDE OF THE VEHICLE AT A TIME) AND INSTALL THE MOUNTING BRACKETS PER THE FOLLOWING INSTRUCTIONS. **NOTE: THE REGULAR CAB APPLICATION WILL NOT USE THE REAR CAB MOUNTING BRACKET ASSEMBLY. IT WILL ONLY USE THE FRONT AND CENTER BRACKETS (ITEM #2, #3, #4, #5).**
 - 4.1. INSTALL THE FRONT MTG BRKT (ITEM #2 & #3) TO THE FRONT CAB MOUNT AS SHOWN (LEAVE THESE FASTENERS FINGER TIGHT).
 - 4.2. INSTALL THE CENTER MTG BRKT (ITEM #4 & #5) TO THE CENTER CAB MOUNT AS SHOWN (LEAVE THESE FASTENERS FINGER TIGHT).
 - 4.3. INSTALL THE REAR INBOARD MTG BRKT (ITEM #8) & WASHER (ITEM #22) TO THE REAR CAB MOUNT AS SHOWN (LEAVE THESE FASTENERS FINGER TIGHT) (EXTENDED AND CREW CAB ONLY).



(A LUVERNE Company)

EXTENDED CAB ONLY

4.3.1. INSTALL THE REAR OUTBOARD CAB MTG BRKT (ITEM #6 & #7) TO THE REAR INBOARD CAB MTG BRKT (ITEM #8), WITH THE 3/8" BLACK ZINC PLATED BOLTS (ITEM #17), WASHERS (ITEM #14) AND SERRATED FLANGE NUTS (ITEM #15). THE REAR OUTBOARD CAB MTG BRKT MUST BE MOUNTED TO THE BACK SIDE OF THE REAR INBOARD MTG BRKT (TOWARDS THE REAR OF THE BEHICLE) AS SHOWN. BE SURE TO USE THE BOTTOM SINGLE HOLE AND BOTTOM DOUBLE HOLES IN THE REAR INBOARD CAB MTG BRKT (SEE FIG 2). PUT THE BOTS THROUGH THE FRONT SIDE OF THE BRACKET SO THE SERRATED FLANGE NUTS ARE ON THE BACK SIDE TO ALLOW CLEARANCE FOR THE FRAME OF THE TRUCK. TORQUE THE BOLTS TO 19 LB. FT.

CREW CAB ONLY

4.3.2. INSTALL THE REAR OUTBOARD CAB MTG BRKT (ITEM #6 & #7) TO THE REAR INBOARD CAB MTG BRKT (ITEM #8), WITH THE 3/8" BLACK ZINC PLATED BOLTS (ITEM #17), WASHERS (ITEM #14) AND SERRATED FLANGE NUTS (ITEM #15). THE REAR OUTBOARD CAB MTG BRKT MUST BE MOUNTED TO THE BACK SIDE OF THE REAR INBOARD CAB MTG BRKT (TOWARDS THE REAR OF THE VEHICLE) AS SHOWN. BE SURE TO USE THE BOTTOM SINGLE HOLE AND TOP DOUBLE HOLES IN THE REAR INBOARD CAB MTG BRKT (SEE FIG 3). PUT THE BOLTS THROUGH THE FRONT SIDE OF THE BRACKET SO THE SERRATED FLANGE NUTS ARE ON THE BACK SIDE TO ALLOW CLEARANCE FOR THE FRAME OF THE TRUCK. TORQUE THE BOLTS TO 19 LB. FT.

5. ATTACH THE SPRING HANGER MOUNTING BRACKETS (ITEM #9 & #10) AGAINST THE SIDE OF THE VEHICLE SPRING HANGER AS SHOWN.
 - 5.1. LOOSEN THE SPRING HANGER BOLT JUST ENOUGH SO THAT THE INBOARD SPRING HANGER MTG BRKT (ITEM #10) CAN BE SLID UP BEHIND THE FLANGE OF THE BOLT. POSITION THE INBOARD SPRING HANGER MTG BRKT BEHIND THE FLANGE OF THE SPRING HANGER BOLT, WITH THE CHANNEL OPEN TO THE OUTBOARD SIDE, AS SHOWN.
 - 5.2. INSTALL THE OUTBOARD SPRING HANGER MTG BRKT (ITEM #9) SO THAT THE INBOARD VERTICAL PORTION OF THE BRACKET FITS INSIDE THE CHANNEL SHAPE OF THE INBOARD SPRING HANGER MTG BRKT USING THE 3/8" ZINC PLATED BOLT, WASHERS, 1/2" WASHERS, AND 3/8" ZINC PLATED NYLOCK NUT (ITEMS #18 - #21) AS SHOWN. (LEAVE THE FASTENERS FINGER TIGHT).
6. ATTACH THE STEP (ITEM #1) TO THE MOUNTING BRACKETS.
 - 6.1. INSERT FOUR (4) (THREE [3] IF YOU ARE USING CAB LENGTH BOARDS) 5/16" SQUARE HEAD SCREWS (ITEM #11) IN THE CENTER SLOT ON THE NDERSIDE OF THE STEP.
 - 6.2. POSITION THE STEP ON THE MOUNTING BRACKETS SO THAT THE SQUARE HEAD SCREWS ARE LOCATED IN THE CENTER TWO (2) SLOTS OF THE BRACKETS (SEE FIG 1,2, OR 3) AND THE FRONT OF THE STEP IS ABOUT EVEN WITH THE REAR METALLIC FLANGE OF THE FRONT WHEEL WELL.
 - 6.3. LOCATE THE STEP IN AND OUT AS DESIRED AND INSTALL THE 5/16" SERRATED FLANGE NUTS (ITEM #12) ON THE SQUARE HEAD SCREWS. TIGHTEN THE NUTS TO 19 LB. FT.
 - 6.4. TIGHTEN THE BODY MOUNT BOLTS PER MANUFACTURERES SPECS.
 - 6.5. TIGHTEN THE SPRING HANGE BOLT PER MANUFACTURERES SPECS.
 - 6.6. TIGHTEN ALL REMAINING 3/8" BOLTS/NUTS TO 19 LB. FT.

SERVICE PARTS LIST

ITEM	PART NO.	QTY	DESCRIPTION
1		2	MEGA STEP BOARD ASSEMBLY (SOLD SEPARATELY) LENGTH WILL VARY DEPENDING ON APPLICATION
2	551901	1	BRACKET-MTG, CAB, FRONT, LH, 571117
3	551904	1	BRACKET-MTG, CAB, FRONT, RH, 571117
4	551902	1	BRACKET-MTG, CAB, CENTER LH, 571117
5	551905	1	BRACKET-MTG, CAB, CENTER RH, 571117
6	551903	1	BRACKET-MTG, CAB, REAR, OUTBOARD, LH, 571117
7	551906	1	BRACKET-MTG, CAB, REAR, OUTBOARD, RH, 571117
8	551907	2	BRACKET-MTG, CAB, REAR, INBOARD, LH/HR, 571117
9	551669	2	BRACKET-MTG, SPRING HANGER, OUTBOARD, 571117
10	551806	2	BRACKET-MTG, SPRING HANGER, INBOARD, 571117
11	106880	16	SCREW-SQUARE HEAD, 5/16-18 UNC
12	102680	16	NUT-SERR FLG, HEX, SST, 5/16-18 UNC
13	102592	6	WSHR, RUBBER, .354 ID X 1.00 OD X .75 THK
14	106962	12	WSHR, FL, 3/8" .438 ID X 1.00 OD X .083 THK, BZP
15	106995	24	NUT, SERR FLG, HEX, 3/8-16X1.00 BZP
16	106960	6	STUD, -DBL ENDED, STL, 3/8-16 X 4.50", BZP
17	106963	6	BOLT, 3/8-16X1.00, BZP
18	101326	2	BOLT, HEX HEAD, 3/8-16X2.00, ZP
19	100062	4	WASHER-FL, 3/8", ZP
20	100118	4	WASHER-FL, 1/2", ZP
21	102381	2	NUT-NYLOCK, HEX, 3/8-16, ZP
22	108882	2	WSHR, FL, .59 ID X 1.06 OD X .19 THK, ZP
23	551571	2	BRKT, 90 DEGREE, 3 HOLES
24	106996	2	NUT-SERR FLG, 5/16-18, BZP
25	106998	2	WSHR-FL, SST, 5/16", BZP
26	106997	2	SCREW, HHC, 5/16-18X1.00, BZP



SERVICE PARTS LIST

MODEL NO. -571117

GM REG CAB W2W

FIG. 1

NOTE:
THE MOUNTING PATTERNS MAY NOT BE EXACTLY AS SHOWN. HOWEVER THERE WILL BE ENOUGH FASTENERS TO MAKE THE APPLICATION.

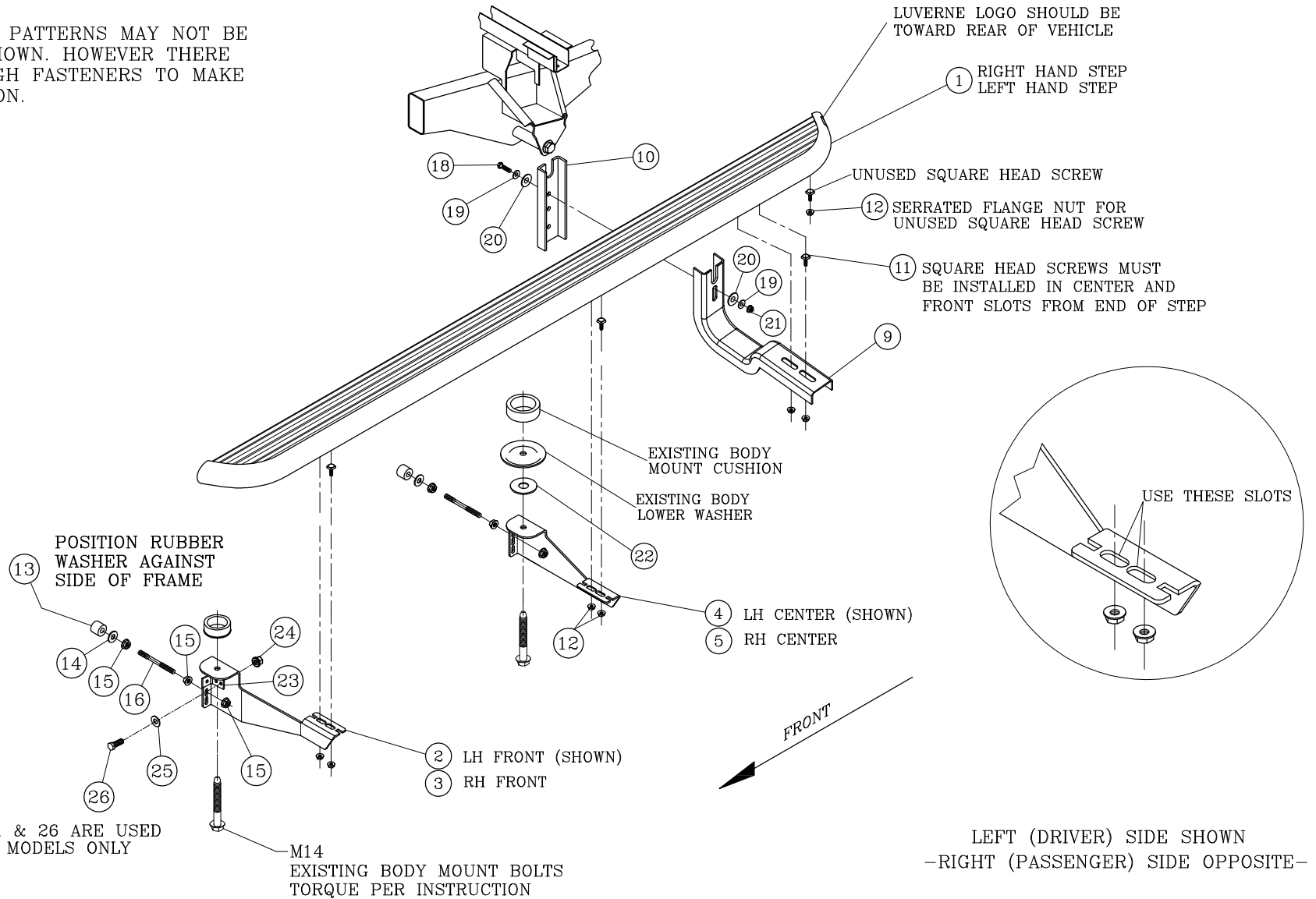

SERVICE PARTS LIST

MODEL NO. -571117

GM EXT CAB W2W

FIG. 2

NOTE:
THE MOUNTING PATTERNS MAY NOT BE EXACTLY AS SHOWN. HOWEVER THERE WILL BE ENOUGH FASTENERS TO MAKE THE APPLICATION.

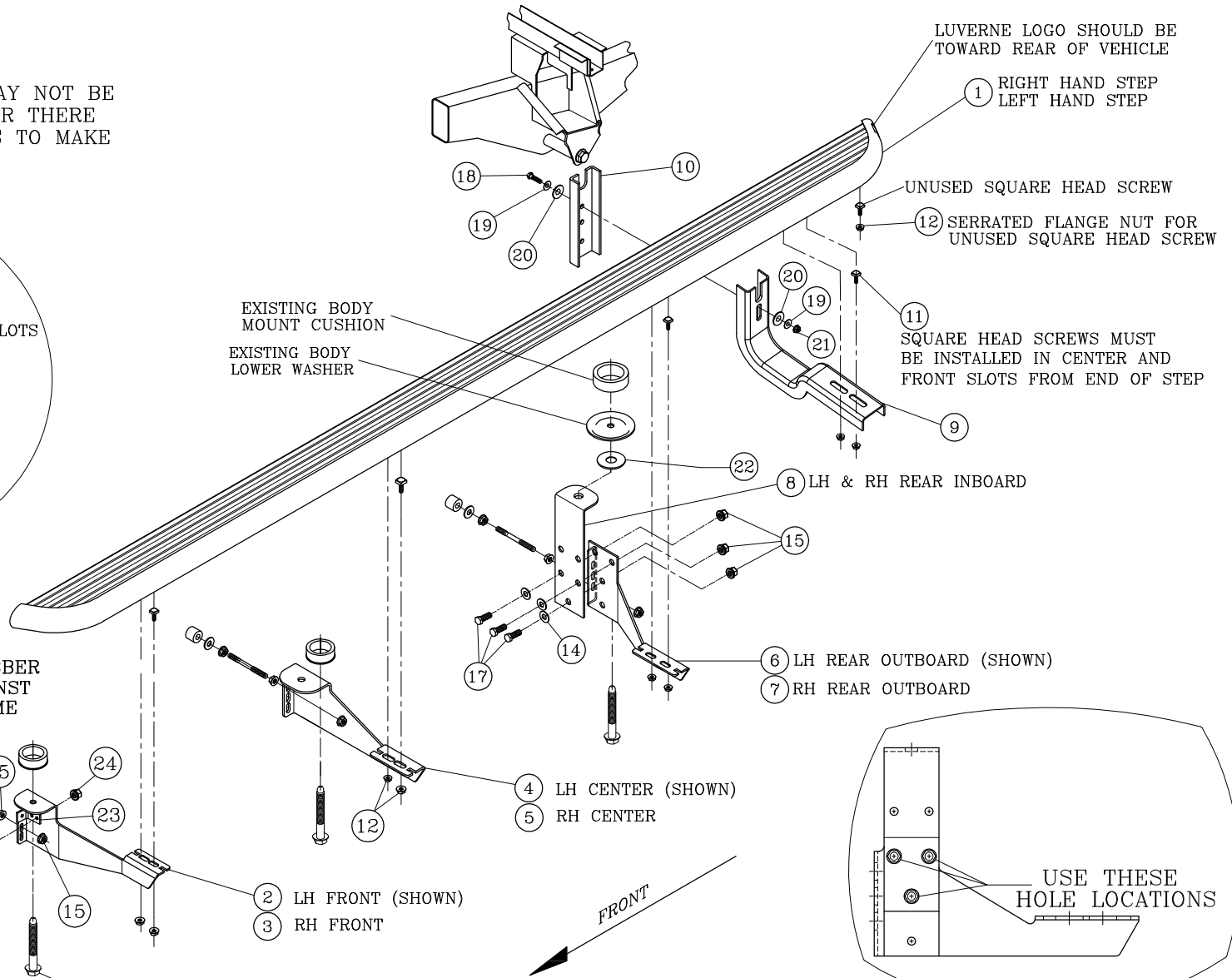
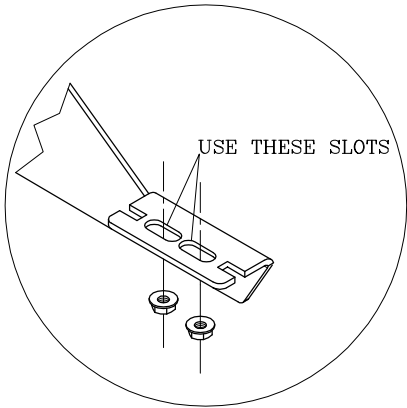

POSITION RUBBER WASHER AGAINST SIDE OF FRAME

EXISTING BODY MOUNT CUSHION
EXISTING BODY LOWER WASHER

LUVERNE LOGO SHOULD BE TOWARD REAR OF VEHICLE

UNUSED SQUARE HEAD SCREW

SERRATED FLANGE NUT FOR UNUSED SQUARE HEAD SCREW

SQUARE HEAD SCREWS MUST BE INSTALLED IN CENTER AND FRONT SLOTS FROM END OF STEP

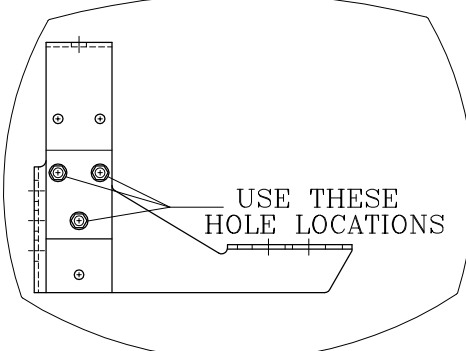

#23, 24, 25, & 26 ARE USED ON 1500 MODELS ONLY

M14 EXISTING BODY MOUNT BOLTS TORQUE PER INSTRUCTION

LEFT (DRIVER) SIDE SHOWN
-RIGHT (PASSENGER) SIDE OPPOSITE-



SERVICE PARTS LIST

MODEL NO. -571117

GM CREW CAB W2W

FIG. 3

NOTE:
THE MOUNTING PATTERNS MAY NOT BE EXACTLY AS SHOWN. HOWEVER THERE WILL BE ENOUGH FASTENERS TO MAKE THE APPLICATION.

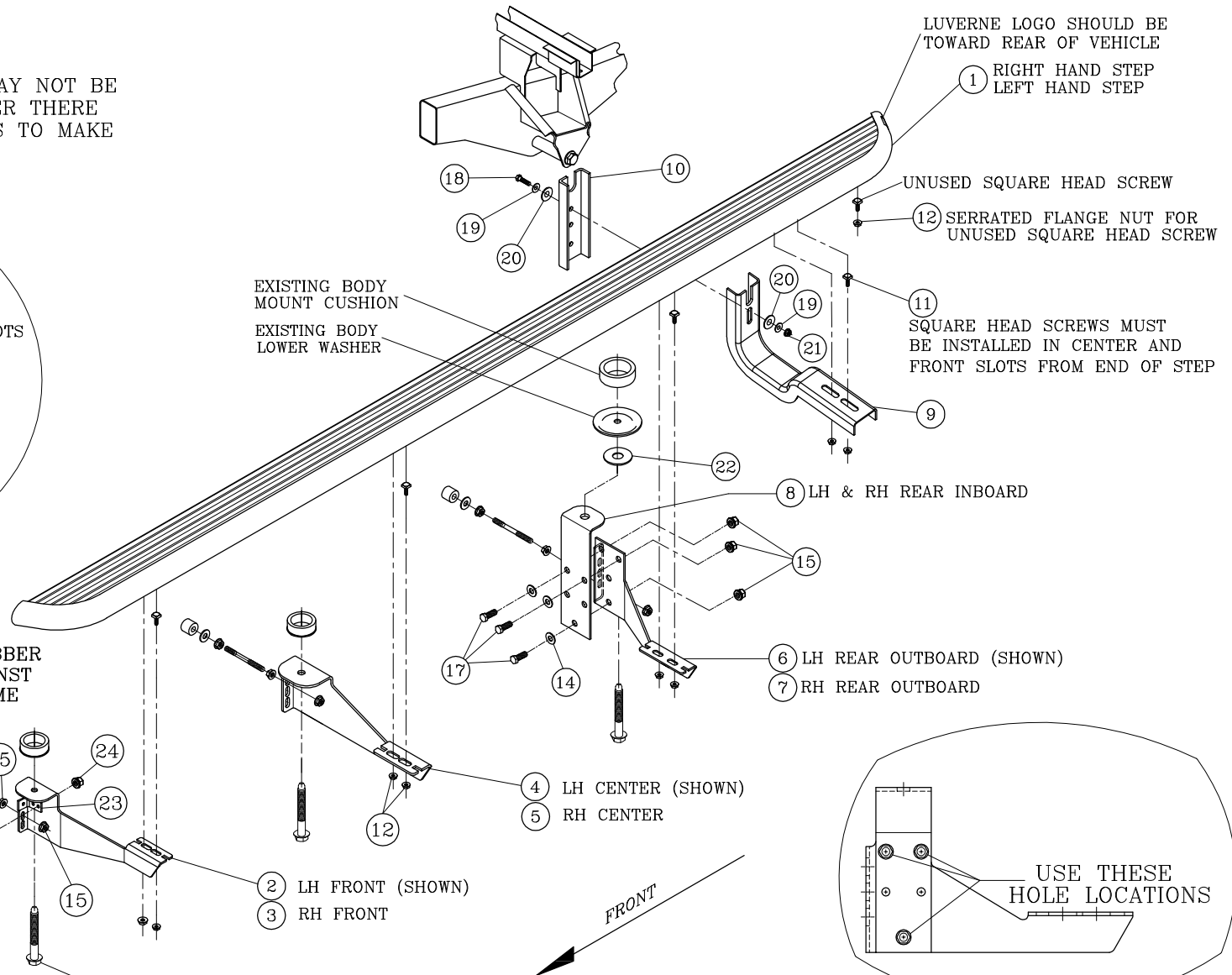
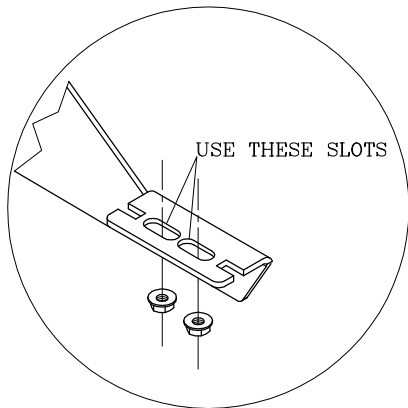

POSITION RUBBER WASHER AGAINST SIDE OF FRAME

LUVERNE LOGO SHOULD BE TOWARD REAR OF VEHICLE

UNUSED SQUARE HEAD SCREW

SERRATED FLANGE NUT FOR UNUSED SQUARE HEAD SCREW

SQUARE HEAD SCREWS MUST BE INSTALLED IN CENTER AND FRONT SLOTS FROM END OF STEP

USE THESE HOLE LOCATIONS

#23, 24, 25, & 26 ARE USED ON 1500 MODELS ONLY

M14 EXISTING BODY MOUNT BOLTS TORQUE PER INSTRUCTION

LEFT (DRIVER) SIDE SHOWN
-RIGHT (PASSENGER) SIDE OPPOSITE-

