

INSTALLATION INSTRUCTIONS AND PARTS LIST

APPLICATION: MODEL 570938 W2W MEGA STEP BRACKETS ON:
09-16 RAM 1500 PICKUPS

1. READ INSTRUCTIONS COMPLETELY AND CHECK TO MAKE SURE THAT ALL REQUIRED PARTS (LISTED ON THE SERVICE PARTS LIST) ARE ON HAND BEFORE STARTING THE INSTALLATION.
2. ATTACH THE MOUNTING BRACKETS TO THE VEHICLE AS FOLLOWS:

RAM TRUCKS WITH THREADED INSERTS IN THE ROCKER PANEL.

- 2.1 PLACE THE DRIVERS SIDE FRONT BRACKET (ITEM #1) UP TO THE PINCHWELD SO THAT THE LOWER MOUNTING FLANGE IS TO THE OUTSIDE OF THE PINCHWELD, ALIGN THE TWO RECTANGULAR HOLES OF THE LOWER MOUNTING FLANGE OF (ITEM #1) WITH THE TWO OBOURD HOLES IN THE PINCHWELD, INSERT THE TWO 1/4-20 X 1" CARRIAGE BOLTS (ITEM #18) THROUGH THE LOWER MOUNTING FLANGE AND THEN THROUGH THE PINCHWELD, PLACE A 1/4" FLAT WASHER (ITEM #19), AND 1/4-20 FLANGE NUT (ITEM #20) ON TO THE CARRIAGE BOLTS, LEAVE FINGER TIGHT. **SEE FIGURES 1 & 2.**
- 2.2 INSERT AN M8 X 25mm SCREW (ITEM #21) WITH A 5/16" FLAT WASHER (ITEM #22) THROUGH THE SLOTS ON THE UPPER MOUNTING FLANGE, LEAVE FINGER TIGHT.
- 2.3 REPEAT STEPS 2.1 & 2.2 ON THE MIDDLE (ITEM #2) AND REAR (ITEM #3) BRACKETS.
- 2.4 FOR THE PASSENGER SIDE THE INSTALLATION IS A MIRROR IMAGE OF THE DRIVERS SIDE, USE (ITEM #2) FOR THE FRONT BRACKET, (ITEM #1) FOR THE MIDDLE BRACKET, & (ITEM #4) FOR THE REAR BRACKET.

RAM TRUCKS WITHOUT THREADED INSERTS IN THE ROCKER PANEL.

- 2.5 ON THE VERTICAL WALL OF THE ROCKER PANEL, INSTALL THE T-BOLT WELDMENT (ITEM #24) INTO THE LARGE OBOURD HOLE INSERTING THE NUT END FIRST, LEAVING THE THREADED STUD STICKING OUT OF THE OBOURD HOLE. **BE CAREFULL NOT TO DROP THE T-BOLT INSIDE OF THE ROCKER PANEL.** ATTACH THE FLAT PLASTIC BOLT RETAINER (ITEM #25) TO THE THREADED STUD OF THE T-BOLT. (THIS IS TO KEEP THE T-BOLT FROM FALLING INTO THE ROCKER PANEL.)
- 2.6 PLACE THE DRIVERS SIDE FRONT BRACKET (ITEM #1) UP TO THE PINCHWELD SO THAT THE LOWER MOUNTING FLANGE IS TO THE OUTSIDE OF THE PINCHWELD, ALIGN THE TWO RECTANGULAR HOLES OF THE LOWER MOUNTING FLANGE OF (ITEM #1) WITH THE TWO OBOURD HOLES IN THE PINCHWELD, INSERT THE TWO 1/4-20 X 1" CARRIAGE BOLTS (ITEM #18) THROUGH THE LOWER MOUNTING FLANGE AND THEN THROUGH THE PINCHWELD, PLACE A 1/4" FLAT WASHER (ITEM #19), AND 1/4-20 FLANGE NUT (ITEM #20) ON TO THE CARRIAGE BOLTS, LEAVE FINGER TIGHT. **SEE FIGURES 3 & 4.**
- 2.7 PLACE A FLAT WASHER (ITEM #22), AND AN M8 FLANGE NUT (ITEM #23), ON THE THREADED STUD OF THE T-BOLT (ITEM #24) LEAVE FINGER TIGHT.
- 2.8 ROTATE THE T-BOLT SO THAT THE THREADED NUT IS VISIBLE THROUGH THE SLOTTED HOLE IN THE UPPER MOUNTING FLANGE, INSERT AN M8 X 25mm SCREW (ITEM #21) WITH A 5/16" FLAT WASHER (ITEM #22), LEAVE FINGER TIGHT.
- 2.9 REPEAT STEPS 2.5 THRU 2.8 ON THE MIDDLE (ITEM #2) AND REAR (ITEM #3) BRACKETS.
- 2.10 FOR THE PASSENGER SIDE THE INSTALLATION IS A MIRROR IMAGE OF THE DRIVERS SIDE, USE (ITEM #2) FOR THE FRONT BRACKET, (ITEM #1) FOR THE MIDDLE BRACKET, & (ITEM #4) FOR THE REAR BRACKET.

NOTE: 2009 TO 2012 TRUCKS DO NOT HAVE THE OBOURD HOLES IN THE PINCH WELD, THEY WILL REQUIRE DRILLING (2) 5/16" HOLES FOR EACH BRACKET, TO GET THE PROPER LOACTION FOR DRILLING FOLOW STEP 2.5, AND THEN SKIP TO STEP 2.7 & 2.8, WITH THE BRACKET IN PLACE, NOW MARK THE PINCHWELD FOR DRILLING.



3. ATTACH THE MOUNTING BRACKETS TO THE BOX OF THE VEHICLE AS FOLLOWS:
 - 3.1. ATTACH THE INBOARD MOUNTING BRACKETS (ITEM #6,7) TO THE FRAME AS SHOWN USING 1/2-13 X 1.00 HEX SCREW, 1/2" WASHER, AND 1/2-13 SERRATED FLANGE NUTS (ITEM #10,11,12). LEAVE THIS BRACKET LOOSE AT THIS TIME. **NOTE THAT THESE MOUNTING BRACKETS ARE NOT THE SAME FROM LEFT TO RIGHT.**
 - 3.2. ATTACH THE W2W SUPPORT BRACKET (ITEM #8) TO THE INBOARD MOUNTING BRACKET USING TWO 3/8-16X 1" HEX SCREWS, TWO 3/8" WASHERS, AND TWO 3/8-16 FLANGE NUTS (ITEMS #9,16, 17) AND TO THE FRAME AS SHOWN USING A 1/2"-13 X 1" HEX SCREW, A 1/2" WASHER, AND A 1/2"-13 SERRATED FLANGE NUT (ITEMS #10,11,12). LEAVE THIS BRACKET LOOSE AT THIS TIME.
 - 3.3. INSTALL THE W2W OUTBOARD MOUNTING BRACKET (ITEM #5) TO THE INBOARD W2W BRACKET AS SHOWN USING TWO BLACK 5/16"-18 X 1" HEX SCREWS, TWO BLACK 5/16" WASHERS AND TWO BLACK 5/16"-18 FLANGE NUTS (ITEMS #13,14,15). LEAVE THIS BRACKET LOOSE AT THIS TIME

4. INSTALL THE STEP PLATES, AND ADJUST BRACKETS, AND BOARDS BEFORE TIGHTENING ALL THE FASTENERS

SERVICE PARTS LIST

ITEM	PART NO.	QTY	DESCRIPTION
1	553006	2	BRKT-MTG, WLDMNT, FRONT LH, MID RH. 571632
2	553007	2	BRKT-MTG, WLDMNT, FRONT RH, MID LH. 571632
3	553008	1	BRKT-MTG, WLDMNT, REAR LH, 571632
4	553009	1	BRKT-MTG, WLDMNT, REAR RH, 571632
5	551721	2	BRKT-MTG, MS, W2W, OUTBOARD
6	551694	1	BRKT-MTG, MS, W2W, RH, INBOARD
7	551693	1	BRKT-MTG, MS, W2W, LH, INBOARD
8	552875	2	BRKT-MTG, W2W, SUPPORT
9	100040	4	SCR-HEX HD, 3/8-16 X 1.0" UNC, ZP
10	100118	4	WASHER, FLAT, 1/2" ZP
11	100085	4	SCR-HEX HD, 1/2"-13 X 1",ZP
12	100123	4	NUT-HEX, FLG, 1/2"-13
13	106996	4	NUT-SERR FLG, SST, 5/16"-18, BZP
14	106997	4	SCR-HEX HD, 5/16"-18 X 1.00", BZP
15	106998	4	WASHER, SST, 5/16", BZP
16	100062	4	WSHR, FLAT, 3/8", .438 ID X 1.00 OD X .083" THK
17	100181	4	NUT, SERR FLG, HEX, 3/8-16 UNC, ZP
18	101320	12	BLT-CRG, 1/4-20 X 1.00", SST, BLK, EM6219
19	101370	12	WSHR-FL, SST, .281 X .625 X .065
20	102366	12	NUT-FLG, HEX, 1/4-20, SST
21	102549	12	SCR-HEX HD, M8 X 1.25 X 25mm, ZP
22	100034	12	WSHR-FL, 5/16, ZP
23	105859	6	NUT HEX-FLG, M8 X 1.25, ZP
24	553012	6	T-BOLT WELDMNT, ZP, 571632
25	101572	6	BOLT RETAINER-PLASTIC, 8mm

SERVICE PARTS LIST

BRACKET NO. - 570938

Fig.1

INSTALLATION ON ROCKER PANELS WITH THREADED INSERTS

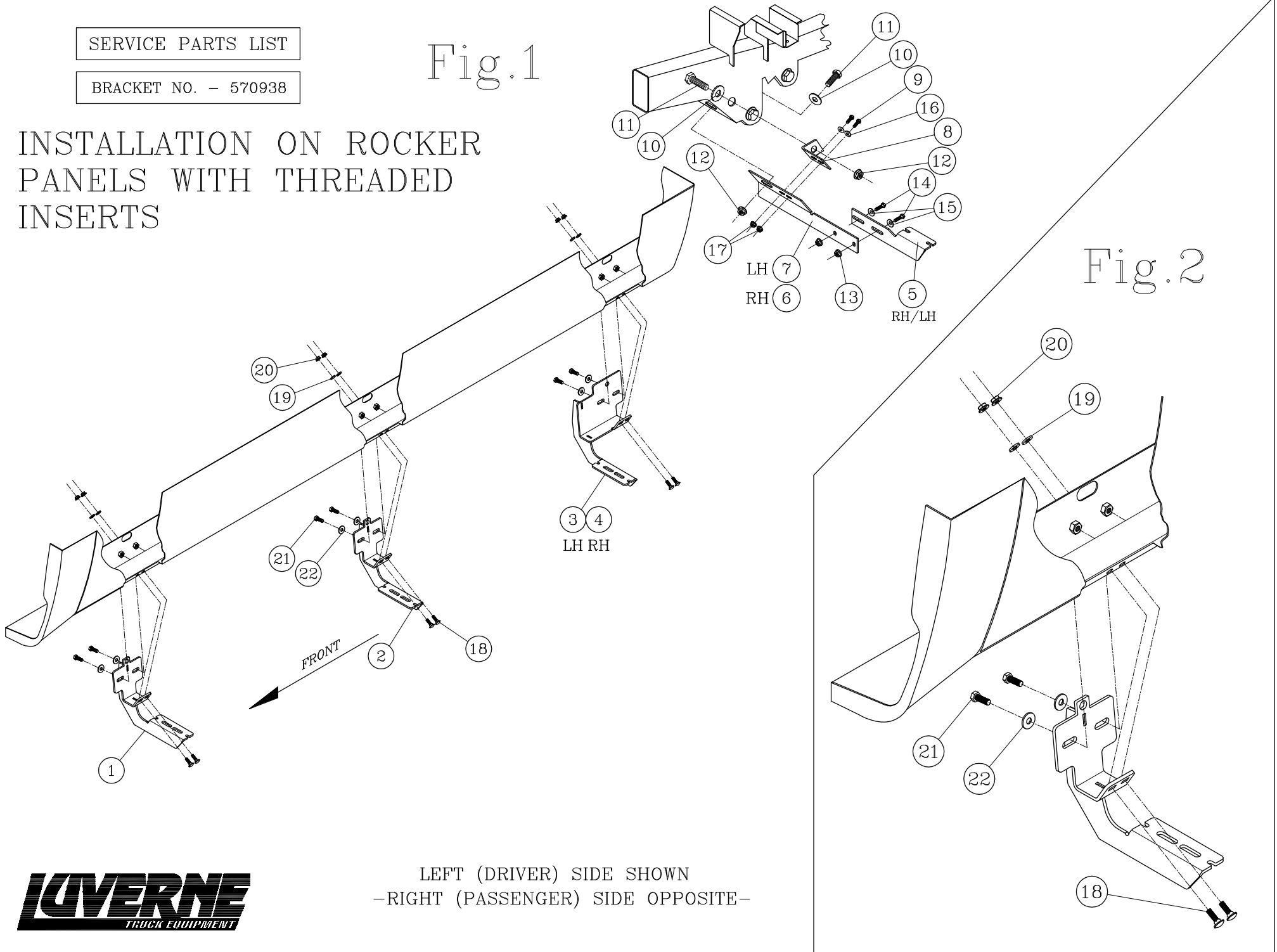

Fig.2

LEFT (DRIVER) SIDE SHOWN
-RIGHT (PASSENGER) SIDE OPPOSITE-



SERVICE PARTS LIST

BRACKET NO. - 570938

INSTALLATION ON ROCKER PANELS WITHOUT THREADED INSERTS

Fig. 3

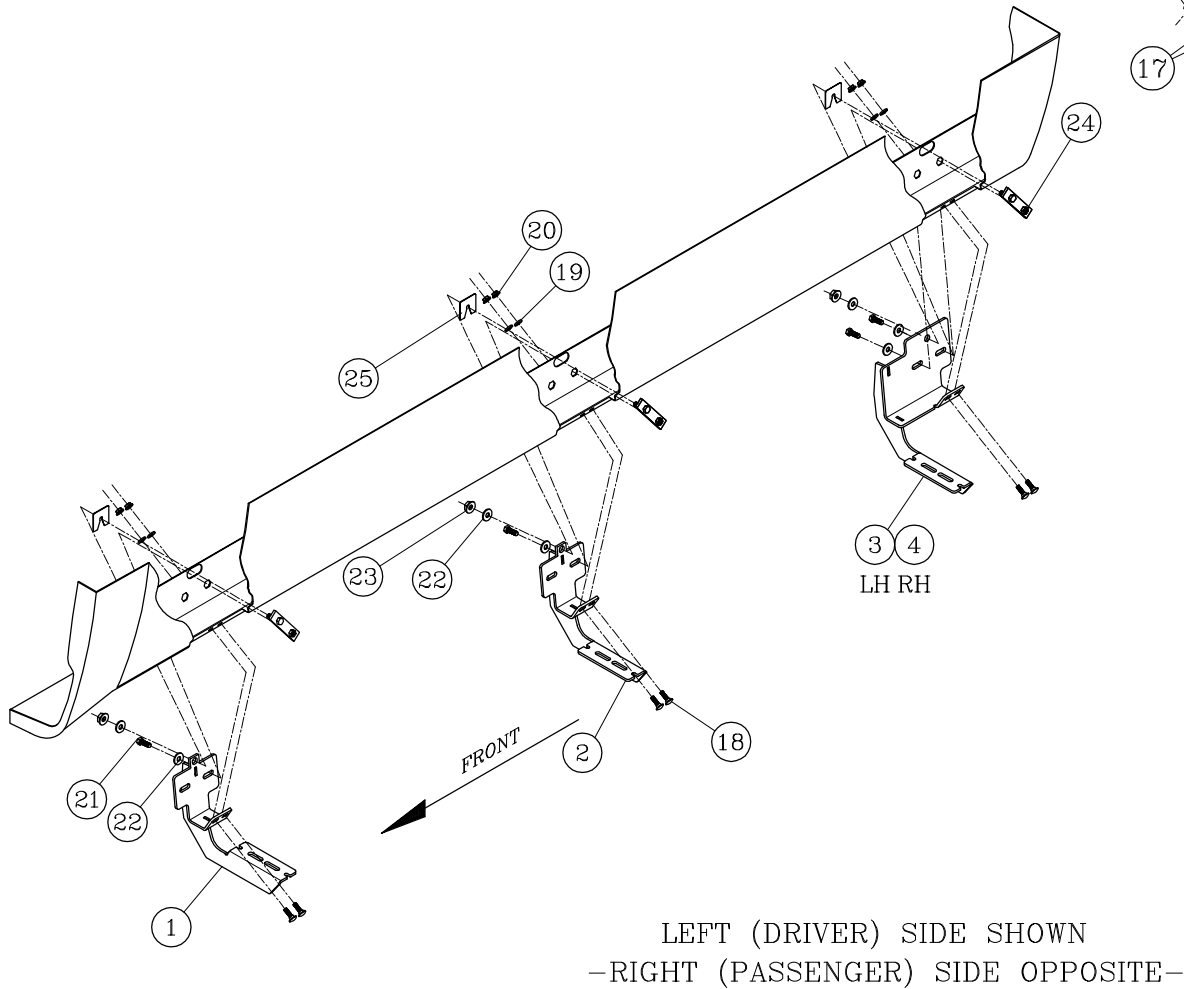

LEFT (DRIVER) SIDE SHOWN
-RIGHT (PASSENGER) SIDE OPPOSITE-

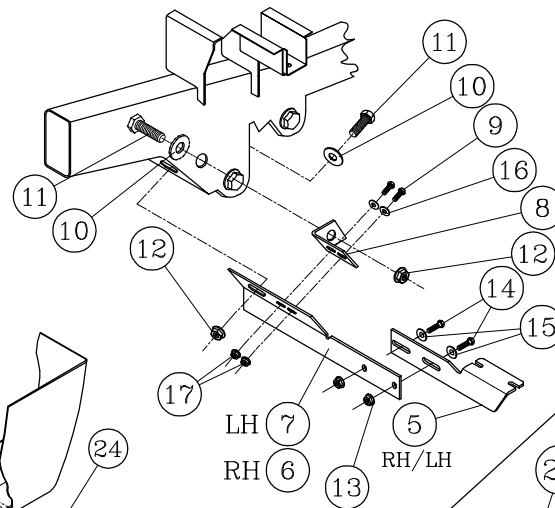
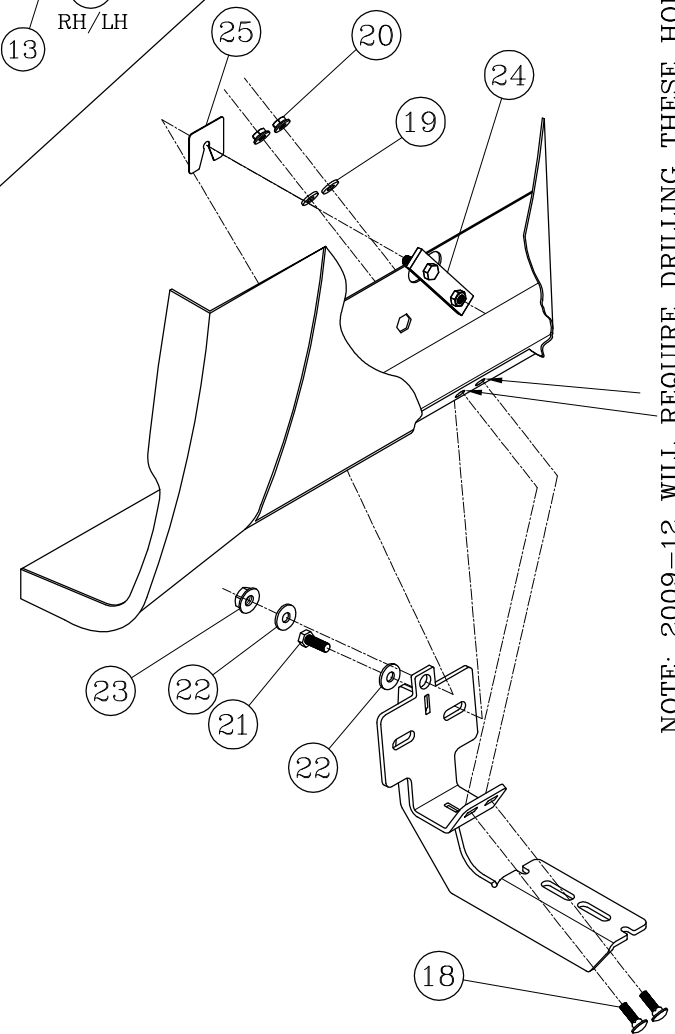

Fig. 4



NOTE: 2009-12 WILL REQUIRE DRILLING THESE HOLES IN THE PINCHWELD.



Choose reliable running boards offered on our website.