

INSTALLATION INSTRUCTIONS AND PARTS LIST

MODEL 570121 O-MEGA STEPS

VEHICLE APPLICATION:

2001 AND NEWER FORD CUT-A-WAY VANS

READ INSTRUCTIONS COMPLETELY AND CHECK TO MAKE SURE THAT ALL REQUIRED PARTS (LISTED ON SERVICE PARTS LIST) ARE ON HAND BEFORE STARTING THE INSTALLATION.

1. ON THE PASSENGERS SIDE OF THE VEHICLE, REMOVE THE TAPE THAT IS COVERING THE MOUNTING HOLES IN THE INSIDE QUARTER PANEL (TWO FRONT LOCATIONS).
2. INSTALL THE SHORT 5/16-18" MULTI THREAD U-NUTS (ITEM #11) IN THE RECTANGULAR AND ROUND HOLES AT THE 1ST HOLE FROM THE FRONT. INSTALL THE LONG 5/16-18" MULTI THREAD U-NUT (ITEM #12) IN THE RECTANGULAR AND ROUND HOLE AT THE 2ND SET OF HOLES FROM THE FRONT.
3. INSTALL THE MOUNTING BRACKETS (ITEMS #2 & #4) USING THE 5/16-18 X 1" HEX BOLTS (ITEM #8), 5/16" FLAT WASHERS (ITEM #15) AND 5/16" LOCK WASHERS (ITEM #16) AS SHOWN IN *fig. 1*. INTO THE MULTI THREAD U-NUTS. FINGER TIGHTEN ONLY AT THIS TIME.
4. INSTALL THE 5/16-18 X 1" HEX BOLTS (ITEM #8), 5/16" FLAT WASHERS (ITEM #15) AND BLACK PLATED 5/16" SERRATED FLANGE NUTS (ITEM #14) THROUGH THE HOLES IN THE LOWER PINCH WELD AND THE BRACKET AS SHOWN IN *fig 1*. FINGER TIGHTEN ONLY AT THIS TIME. **(NOTE: IF YOUR VEHICLE DOES NOT HAVE HOLES IN THE PINCH WELD THEY WILL HAVE TO BE DRILLED. MAKE SURE THE BRACKETS ARE TIGHT AGAINST THE BODY PANELS, AND USING THE HOLE IN THE BRACKETS AS A GUIDE, DRILL AN Ø11/32" HOLE THROUGH THE PINCH WELD AT EACH BRACKET.)**
5. MAKE SURE THE TWO FRONT BRACKETS ARE UP TIGHT AGAINST THE VEHICLE SURFACE AT THE TOP AND TIGHTEN THE BOLT THAT GOES THROUGH THE PINCH WELD THEN TIGHTEN THE BOLTS THAT GO INTO THE U-NUTS. TIGHTEN THE BOLTS TO 19 FOOT POUNDS OF TORQUE.
6. REPEAT STEPS #1 - #5 ON THE DRIVERS SIDE.
7. THE O-MEGA STEP PLATES (MODEL #585054) USED FOR THIS APPLICATION WILL NEED TO BE CUT DOWN TO THE PROPER LENGTH, APPROXIMATELY 36-1/2". REMOVE THE END CAP FROM THE UNBOLTED END. USING A HACKSAW OR BAND SAW, CUT THE STEP PLATES TO LENGTH.

NOTE: SEE THE MOUNTING INSTRUCTION THAT COME WITH THE STEP PLATES FOR STEP PAD MOUNTING INSTRUCTIONS.

8. INSTALL THREE SQUARE HEAD SCREWS, 5/16-18 X 1" (ITEM #9) IN THE FRONT AND REAR TRACK OF THE STEP PLATES.
9. REINSTALL THE END CAP BACK ON THE END OF THE STEP PLATE AND BOLT IT DOWN WITH THE END SET OF BOLTS.
10. POSITION THE O-MEGA STEP ON THE MOUNTING BRACKETS SO THAT THE SQUARE HEAD SCREWS ARE LOCATED IN THE SLOTS OF THE MOUNTING BRACKETS AND THE STEP IS CENTERED, FRONT TO REAR ON THE VEHICLE. INSTALL 5/16" SERRATED FLANGE NUTS (ITEM #13) ON THE SQUARE HEAD SCREWS. TIGHTEN THE STEP PLATE MOUNTING BOLTS TO 19 FOOT POUNDS OF TORQUE.



(A LUVERNE Company)

SERVICE PARTS LIST

| ITEM | PART NO. | QTY | DESCRIPTION |
|------|----------|-----|--|
| 1 | 585054 | 1 | O-MEGA STEP ASSY- 54.00" (MOD. 585054) |
| 2 | 551789 | 1 | MOUNTING BRACKET – FRONT, RH |
| 3 | 551790 | 1 | MOUNTING BRACKET - FRONT, LH |
| 4 | 551791 | 1 | MOUNTING BRACKET – CENTER, RH |
| 5 | 551792 | 1 | MOUNTING BRACKET – CENTER, LH |
| 6 | 107956 | 4 | PLASTIC END CAP – 2.95" X 6.70" |
| 7 | 107957 | 2 | STEP PAD 4-1/2" X 20" |
| 8 | 106997 | 8 | SCREW – HHC, 5/16-18" X 1", BZP |
| 9 | 106880 | 16 | SCREW-SQUARE HD, 5/16-18 X 1" |
| 10 | 107958 | 12 | PHILLIPS HEAD TEK SCREW - #8-18 X 1/2, SST |
| 11 | 104264 | 2 | U-NUT – MULTI THREAD, 5/16-18" |
| 12 | 105541 | 2 | U-NUT – MULTI THREAD, 5/16-18", LONG |
| 13 | 102680 | 16 | NUT – SERRATED FLANGE, 5/16-18", SST |
| 14 | 106996 | 4 | NUT – SERRATED FLANGE, 5/16-18", BZP, SST |
| 15 | 106998 | 12 | FLAT WASHER - 5/16", SST, BZP |
| 16 | 102668 | 4 | LOCK WASHER - 5/16", SST |

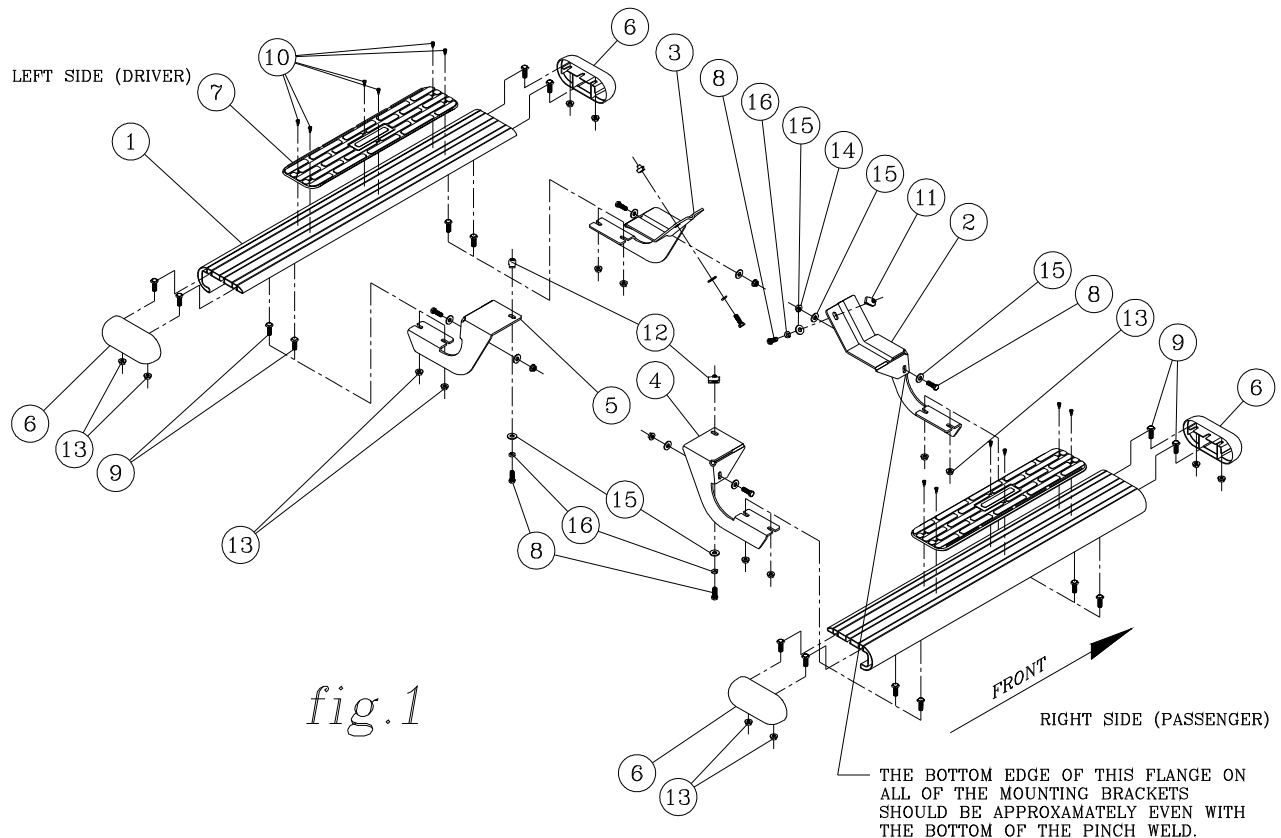

SERVICE PARTS LIST

MODEL NO. - 570121

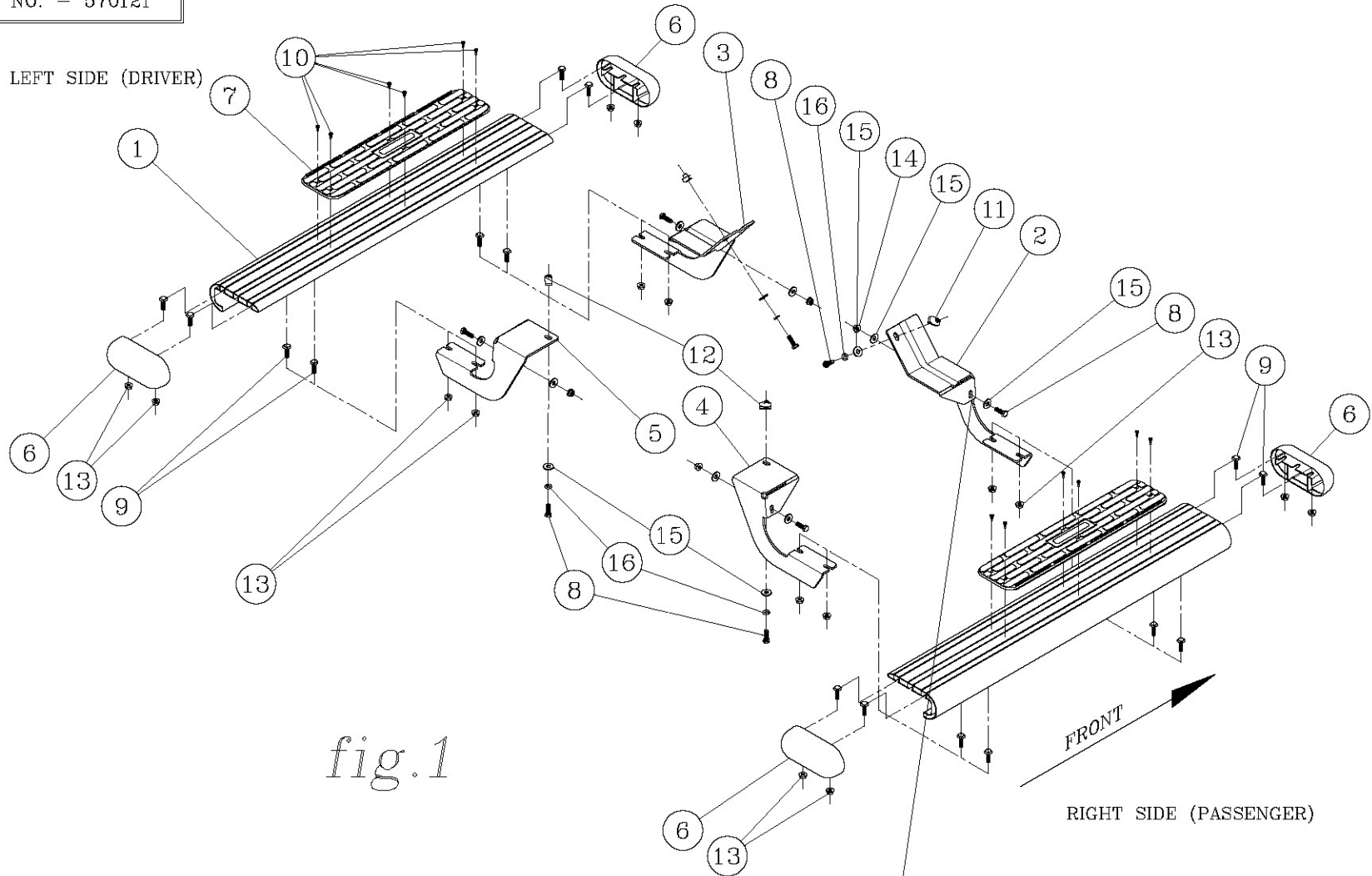

fig.1

LIVERNE
TRUCK EQUIPMENT
(A LIVERNE Company)

THE BOTTOM EDGE OF THIS FLANGE ON ALL OF THE MOUNTING BRACKETS SHOULD BE APPROXIMATELY EVEN WITH THE BOTTOM OF THE PINCH WELD.