

## INSTALLATION INSTRUCTIONS AND PARTS LIST

APPLICATION: MODEL **481510/481515** (STAINLESS STEEL) SIDE ENTRY STEP BOARDS:  
**2015 GM COLORADO/CANYON**

1. READ INSTRUCTIONS COMPLETELY AND CHECK TO MAKE SURE THAT ALL REQUIRED PARTS (LISTED ON SERVICE PARTS LIST) ARE ON HAND BEFORE STARTING THE INSTALLATION.
2. WITH THE STEP BOARD BRACKETS ATTACHED TO THE VEHICLE, ON THE LEFT SIDE OF THE VEHICLE PLACE THE STEP BOARD (ITEM #1) ON THE BRACKETS AND CHECK THAT THE MOUNTING HOLES LINE UP. (THE LUVERNE STICKER SHOULD BE ON THE FRONT DRIVERS SIDE)
3. USING SIX (6) 10-24 X .75" CARRIAGE BOLTS (ITEM #3), SIX (6) NEOPRENE WASHERS (ITEM #13), AND SIX (6) 10-24 FLANGE NUTS (ITEM #4) ATTACH THE STEP BOARD TO THE BRACKETS.

**NOTE: OUTER CARRIAGE BOLT (ITEM #6) FOR BOTH MIDDLE BRACKETS WILL BE UNDER THE STEP PAD, AND WILL BE PRE-INSTALLED FROM THE FACTORY.**

4. ADJUST STEP IN/OUT TO ALIGN STEP WITH THE CAB.
5. TIGHTEN STEP MOUNTING BOLTS.
6. REPEAT FOR RIGHT SIDE OF VEHICLE.

### SERVICE PARTS LIST

ITEM	PART NO.	QTY	DESCRIPTION
1	552807	1	STEP PLATE-SES,LH,481510
2	552806	1	STEP PLATE-SES,RH,481510
1	552789	1	STEP PLATE-SES,LH,481515
2	552788	1	STEP PLATE-SES,RH,481515
3	104258	12	BOLT – CARRIAGE, 10-24 X .75", SST
4	104261	36	NUT – FLANGE, 10-24, SST
5	104250	2	END CAP – RH FRONT/LH REAR
6	104251	2	END CAP – LH FRONT/RH REAR
7	104255	2	TRIM – SEAL, EXTRUSION, 80.50"
8	105500	4	STEP PAD, 5.50 X 20.00
9	104257	8	NUT – HEX, SINGLE THREAD
10	107958	4	SCR-PPH, #8-18 X .5", SST
11	107645	4	CLIP-U, .118-.185,BLK
12	107863	24	BOLT – CARRIAGE, 10-24 X .5", BZP
13	104530	12	WSHR-FL, NPRN, .200X.468X.031



(A LUVERNE Company)

## INSTALLATION INSTRUCTIONS AND PARTS LIST

APPLICATION: MODEL 571515 MEGA-OMEGA/SIDE ENTRY STEP BRACKETS ON:  
2015 GM COLORADO/CANYON CREW CAB PICK UP.  
**ROCKER PANEL MOUNT APPLICATION**



### NO DRILL APPLICATION

1. READ INSTRUCTIONS COMPLETELY AND CHECK TO MAKE SURE THAT ALL REQUIRED PARTS (LISTED ON SERVICE PARTS LIST) ARE ON HAND BEFORE STARTING THE INSTALLATION.
2. ON THE LEFT SIDE OF THE VEHICLE REMOVE THE PLASTIC BODY PLUGS THAT ARE LOCATED ON THE BOTTOM & VERTICAL WALL OF THE ROCKER PANEL, AND INSERT A 5/16"-18 U-NUT (ITEM #6) AS SHOWN. USE THE FIRST, SECOND, & FOURTH SET OF HOLES BACK, FROM THE FRONT WHEEL OPENING.
3. POSITION THE MOUNTING BRACKETS (ITEM #1, & 2) SO THAT THE HOLES ON THE BRACKET LINE UP WITH THE HOLES ON THE INSIDE WALL OF THE ROCKER PANEL. INSTALL THE 5/16"-18 X 1.00" HEX BOLTS (ITEM #3), 5/16" LOCK WASHERS (ITEM #4), AND A 5/16" FLAT WASHERS (ITEM #5), FINGER TIGHT.
4. REPEAT STEPS 3 – 4 FOR THE REMAINING BRACKETS.
5. INSTALL THE STEP BOARD AS DESCRIBED BY THE INSTRUCTIONS INCLUDED WITH YOUR STEP BOARDS.
6. TIGHTEN THE MOUNTING BOLTS TO 19 LB-FT STARTING WITH THE BOTTOM BOLTS FOLLOWED BY THE TOP BOLTS.
7. REPEAT STEPS 2 – 7 FOR THE RIGHT SIDE OF THE VEHICLE.

### SERVICE PARTS LIST

ITEM	PART NO.	QTY	DESCRIPTION
1	552790	3	BRKT-MTG, RH FRNT/LH REAR, 571515
2	552791	3	BRKT-MTG, LH FRNT/RH REAR, 571515
3	100647	12	5/16"-18 X 1.00" SCR ZP
4	100034	12	FLAT WASHER, 5/16, ZP
5	100030	12	LOCK WASHER, 5/16, ZP
6	105541	8	U-NUT,5/16"-18

SERVICE PARTS LIST

MODEL NO.-571515

INSERT U-CLIP WITH THREADED  
SIDE TO THE INSIDE OF ROCKER PANEL

REMOVE (6) PLASTIC BODY  
PLUGS PER SIDE

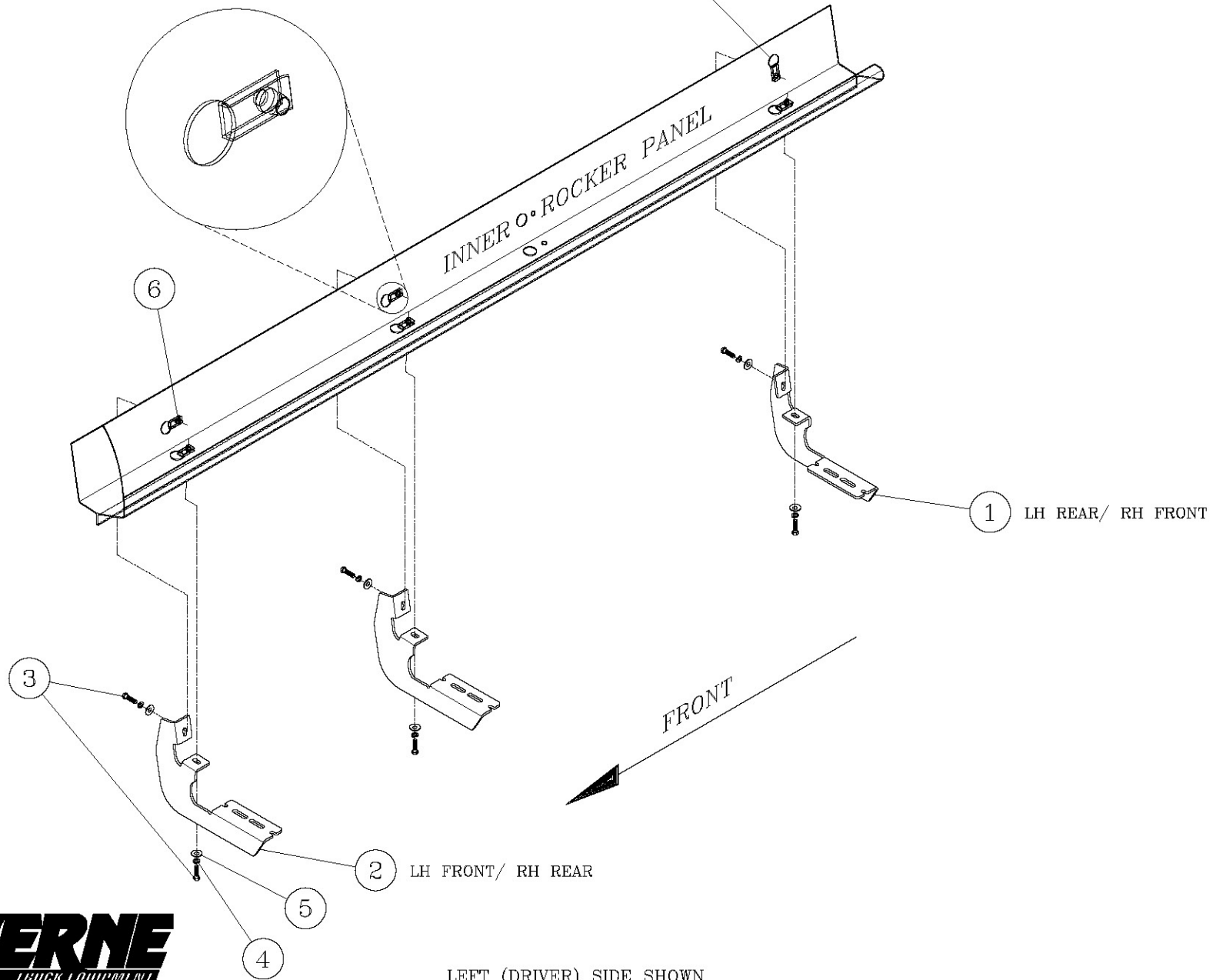

LEFT (DRIVER) SIDE SHOWN  
- RIGHT (PASSENGER) SIDE OPPOSITE -

SERVICE PARTS LIST

MODEL NO.-481510/481515

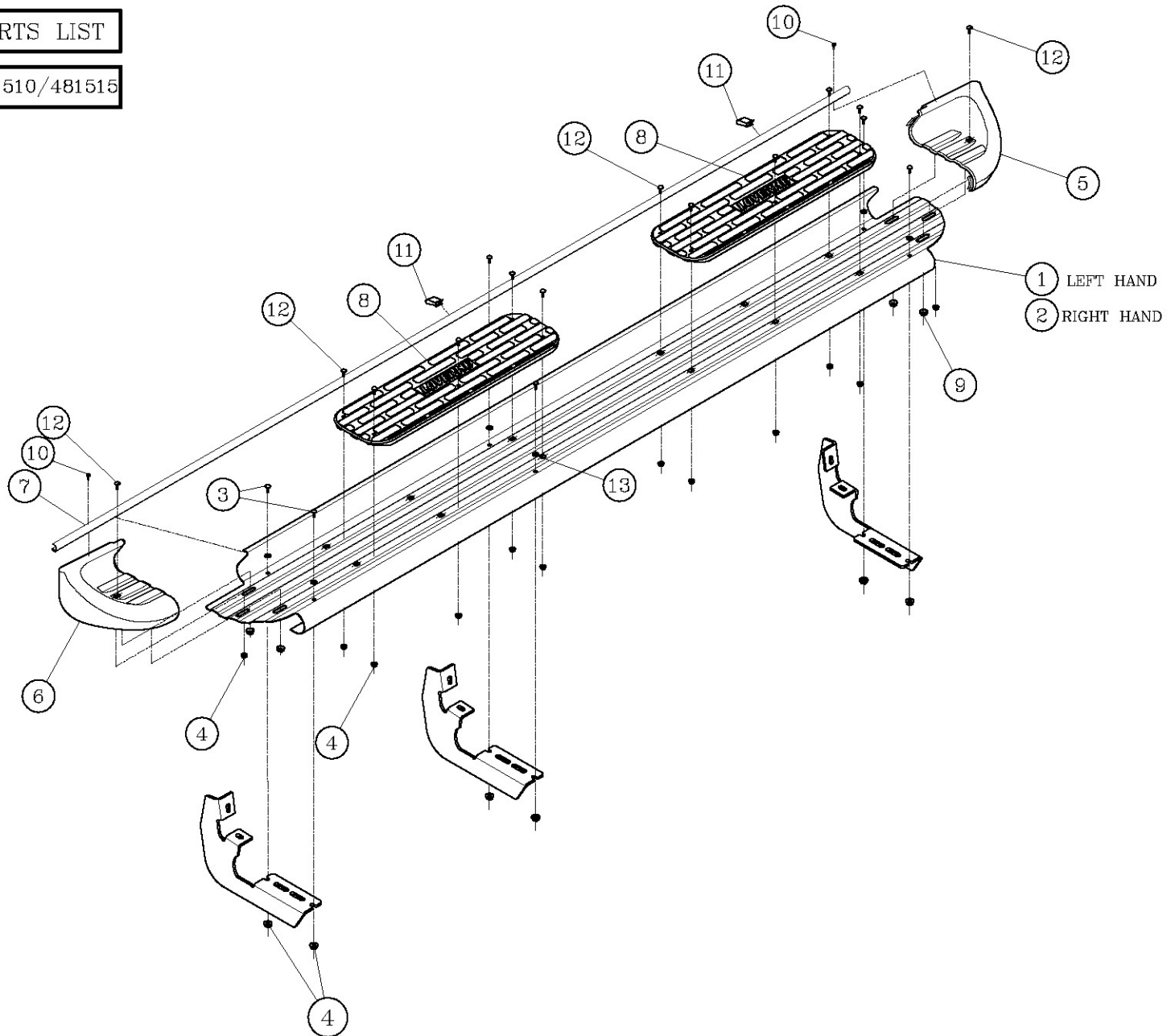

LEFT (DRIVER) SIDE SHOWN  
- RIGHT (PASSENGER) SIDE OPPOSITE -

Choose reliable running boards offered on our website.