

INSTALLATION INSTRUCTIONS AND PARTS LIST

MODELS:

477097, 477101, 477113 (EXTENDED CABS)
477102, 477108, 477114, 477125 (CREW CABS)
REGAL 7 OVAL STEPS (BOARDS ONLY)
UNIVERSAL APPLICATIONS



1. Read instructions completely and check to make sure that all required parts (listed on the service parts list) are on hand before starting the installation.
2. Follow the instructions included with the specific bracket package that you are using to mount the brackets to your vehicle.
3. The step is pre-assembled from the factory. The serial number label is located on the front inside drivers side step assembly.
4. Attaching the step to the mounting bracket:
 - 4.1 Set the step on the mounting brackets, and slide each support mounting plate (item #9) inside the oval step and above each bracket.
 - 4.2 Using the supplied 5/16-18 x 1" black stainless steel hex bolt, washer, and serrated flange nut (items # 10,11&12) attach the step assembly, support mounting plate and mounting bracket.
 - 4.3 Set the step plate in the correct position and tighten all fasteners.
Torque all 5/16" fasteners to 19 LB FT.

INSTALLATION INSTRUCTIONS AND PARTS LIST

APPLICATION: MODEL 571439/401439 W2W MEGA/GRIP STEP BRACKETS ON:
2014+ RAM 2500 PICKUPS



1. READ INSTRUCTIONS COMPLETELY AND CHECK TO MAKE SURE THAT ALL REQUIRED PARTS (LISTED ON SERVICE PARTS LIST) ARE ON HAND BEFORE STARTING THE INSTALLATION.

NOTE: FOR REGULAR CAB PICKUPS ONLY THE FRONT AND REAR CAB MOUNTING BRACKETS ARE USED, THE CENTER MOUNTING BRACKET AND FASTENERS MAY BE DISCARDED.

2. ASSEMBLE THE LOAD REACTION STUDS AND HARDWARE AS FOLLOWS.

NOTE: USE A 4" STUD (ITEM #19) FOR THE FRONT BRACKET AND A 3" STUD (ITEM #18) FOR THE REAR BRACKETS.

- 2.1. ON THE SHORT THREADED END OF THE LOAD REACTION STUD (ITEM #18, 19), INSTALL A 3/8" SERRATED FLANGE NUT (ITEM #17) BACKWARDS TO THE BOTTOM OF THE THREAD. THEN INSTALL A 3/8" FLAT WASHER (ITEM #16) AND RUBBER "CUSHION" WASHER (ITEM # 15) TIGHT UP AGAINST THE SERRATED FLANGE NUT. (THE END OF THE STUD MUST BE RECESSED IN THE RUBBER WASHER APPROX. 3/16").
 - 2.2. ON THE LONG THREADED END OF THE STUD, INSTALL A 3/8" SERRATED FLANGE NUT (ITEM # 17) BACKWARDS TO NEAR TO THE BOTTOM OF THE THREADS
3. ATTACH THE LOAD REACTION STUD ASSEMBLIES TO THE MOUNTING BRACKETS AS SHOWN. INSERT THE STUD, FROM WHAT WILL BE THE INBOARD OR FRAME SIDE THRU THE LOWEST HOLE IN THE BENT FLANGE OF THE BRACKET THAT WILL ALLOW THE RUBBER WASHER TO SEAT FIRM AGAINST THE SIDE WALL OF THE FRAME. INSTALL A FLANGE NUT (ITEM #17) ON THE OUTBOARD END OF THE STUD (FINGER TIGHT ONLY).
 4. ON THE RIGHT SIDE OF THE VEHICLE, REMOVE THE FACTORY FRONT, CENTER, AND REAR BODY MOUNT BOLTS (ONE SIDE OF THE VEHICLE AT A TIME), THESE WILL NOT BE REUSED. INSTALL THE MOUNTING BRACKETS PER THE FOLLOWING INSTRUCTIONS:
 - 4.1. USING A M12 – 110MM BOLT (ITEM #12) AND A 2.0" WASHER (ITEM #14) INSTALL THE FRONT MOUNTING BRACKET (ITEM #1, 2) TO THE FRONT BODY MOUNT AS SHOWN (LEAVE THESE FASTENERS FINGER TIGHT).
 - 4.2. USING A M12 – 110MM BOLT (ITEM #12) AND A 2.0" WASHER (ITEM #14) INSTALL THE CENTER MOUNTING BRACKET (ITEM #3, 4) TO THE CENTER BODY MOUNT AS SHOWN (LEAVE THESE FASTENERS FINGER TIGHT).
 - 4.3. USING A M12 – 116MM BOLT (ITEM #13) AND A 1/2" FLAT WASHER (ITEM #21) INSTALL THE REAR MOUNTING BRACKET (ITEM #5, 6) TO THE REAR BODY MOUNT AS SHOWN (LEAVE THESE FASTENERS FINGER TIGHT). **NOTE: THE ORIENTATION OF THE REAR BRACKET WILL BE DIFFERENT BETWEEN THE REG/QUAD/CREW CAB PICKUPS AND THE MEGA CAB PICKUPS. IF INSTALLING ON A REG/QUAD/CREW CAB PICKUP REFER TO FIG. 1, IF INSTALLING ON A MEGA CAB PICKUP REFER TO FIG. 2.**
 - 4.4. ATTACH THE REAR OUTBOARD MOUNTING BRACKET (ITEM #7, 8) TO THE REAR INBOARD MOUNTING BRACKET (ITEM #5, 6) IN THE UPPER MOUNTING LOCATION, USING THREE 3/8-16 X 1.0" SCREW, 3/8" FLAT WASHERS AND 3/8" FLANGE NUTS. (ITEMS #16, 17, 20).



(A LUVERNE Company)

5. ATTACH THE MOUNTING BRACKETS TO THE SHACKLE MOUNT OF THE VEHICLE AS FOLLOWS.
 - 5.1. ATTACH THE UPPER MOUNTING BRACKET (ITEM #9) TO THE SIDE OF THE SUSPENSTION LINK HOUSING BY LOOSENING THE BOLT THAT FASTENS THE SUSPENSION LINKS TO THE VEHICLE. SLIDE THE UPPER MOUNTING BRACKET (ITEM #9) BETWEEN THE BOLT HEAD AND THE FRAME BRACKET. TIGHTEN DOWN THE BOLT MAKING SURE THAT THE UPPER MOUNTING BRACKET (ITEM #9) IS LEVEL.
 - 5.2. FASTEN THE LOWER BRACKET (ITEM #11) TO THE UPPER BRACKET (ITEM #9) USING 3/8 BOLT, WASHER AND NUT (ITEM #16, 17, 20) USING THE TWO LOWER HOLES IN THE UPPER BRACKET. MAKING SURE THAT IT SIT'S LEVEL TO THE FRONT BRACKETS.
6. ATTACH THE STEP PLATE PER THE INSTRUCTIONS INCLUDED WITH YOUR STEP PLATE ASSEMBLY.
7. POSITION THE LOAD REACTION STUD ASSY SO THAT THE RUBBER CUSHION IS SNUG UP AGAINST THE SIDE OF THE FRAME. TIGHTEN THE 3/8" FLANGE NUTS ON EITHER SIDE OF THE BRACKET TO 19LB. FT.

SERVICE PARTS LIST

ITEM	PART NO.	QTY	DESCRIPTION
1	552850	1	BRKT-MTG, MS, FRONT, LH, BODY MOUNT
1	552862	1	BRKT-MTG, GRIP, FRONT, LH, BODY MOUNT
2	552851	1	BRKT-MTG, MS, FRONT, RH, BODY MOUNT
2	552863	1	BRKT-MTG, GRIP, FRONT, RH, BODY MOUNT
3	552852	1	BRKT-MTG, MS, CENTER, LH, BODY MOUNT
3	552864	1	BRKT-MTG, GRIP CENTER, LH, BODY MOUNT
4	552853	1	BRKT-MTG, MS, CENTER, RH, BODY MOUNT
4	552865	1	BRKT-MTG, GRIP, CENTER, RH, BODY MOUNT
5	552854	1	BRKT-MTG, REAR, LH, INBOARD, BODY MOUNT
6	552855	1	BRKT-MTG, REAR, RH, INBOARD, BODY MOUNT
7	552856	1	BRKT-MTG, MSREAR, LH, OUTBOARD
7	552868	1	BRKT-MTG, GRIP, REAR, LH, OUTBOARD
8	552857	1	BRKT-MTG, MS, REAR, RH, OUTBOARD
8	552869	1	BRKT-MTG, GRIP, REAR, RH, OUTBOARD
9	552457	1	BRKT-MTG, MS, W2W, LH, INBOARD
9	552411	1	BRKT-MTG, GRIP, W2W, LH, INBOARD
10	552458	1	BRKT-MTG, MS, W2W, RH, INBOARD
10	552412	1	BRKT-MTG, GRIP, W2W, RH, INBOARD
11	551721	2	BRKT-MTG, MS, W2W, LH/RH, LOWER
11	552125	2	BRKT-MTG, GRIP, W2W, LH/RH, LOWER
12	103444	4	SCREW-HEX HEAD, M12 – 1.75 X 110MM, ZP
13	109451	2	SCREW-HEX HEAD, M12 – 1.75 X 160MM, YZP
14	105909	4	WSHR-FLAT, 2.0 X .509 X .179, ZP
15	102592	6	WSHR, RUBBER, .354 ID X 1.00 OD X .75 THK
16	100062	16	WSHR, FLAT, 3/8", .438 ID X 1.00 OD X .083" THK
17	100181	28	NUT, SERR FLG, HEX, 3/8-16 UNC, ZP
18	104697	4	STUD, STL, 3/8-16 X 3.00", ZP
19	104686	2	STUD, -DBL ENDED, STL, 3/8-16 X 4.00", ZP
20	100040	10	SCR-HEX HD, 3/8-16 X 1.0" UNC, ZP
21	100118	2	WASHER, FLAT, 1/2" ZP

SERVICE PARTS LIST

MODEL NO.-571439/401439

FIG. 1 CREW/QUAD CAB

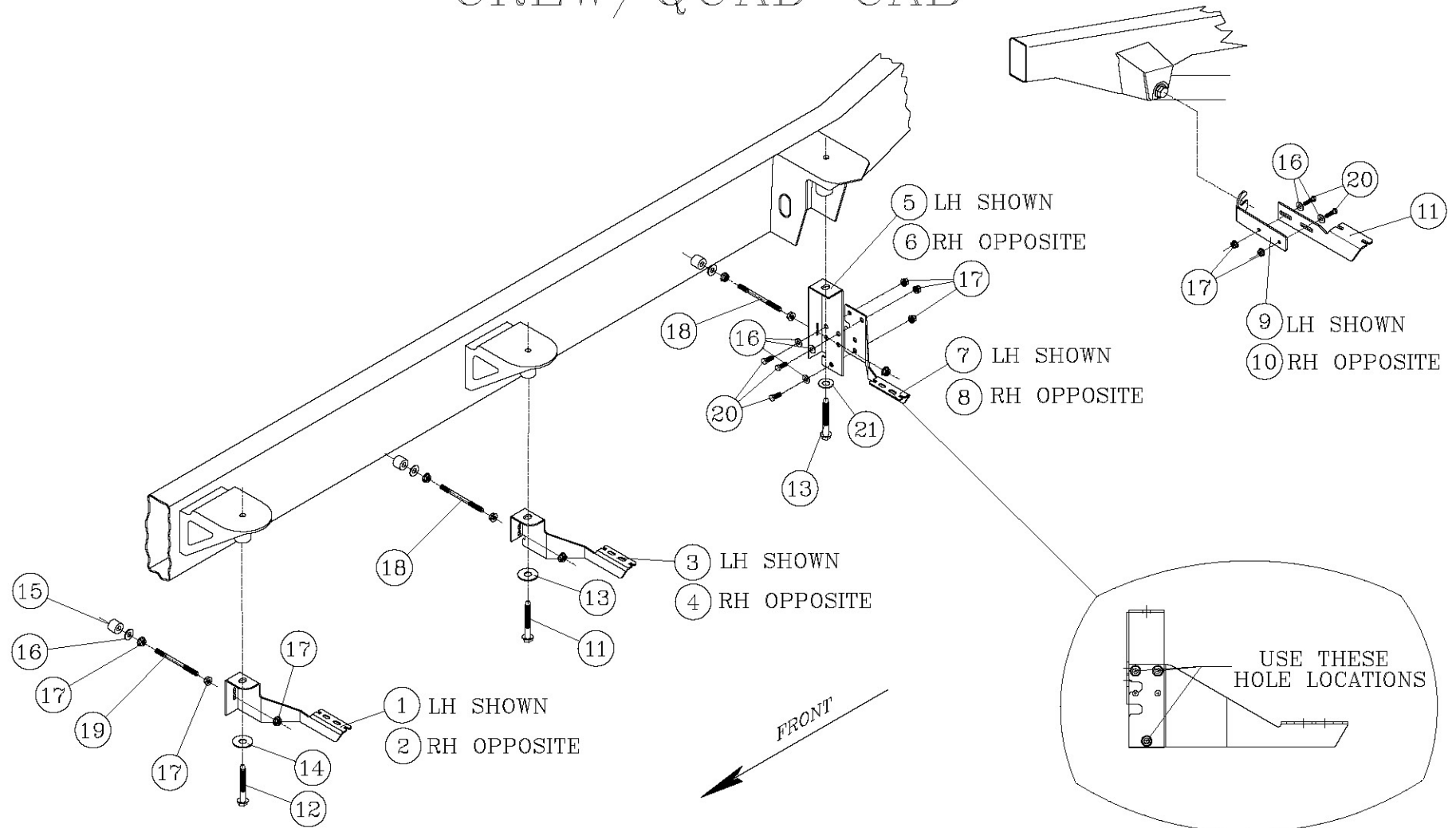

LEFT (DRIVER) SIDE SHOWN



LEFT (DRIVER) SIDE SHOWN
-RIGHT (PASSENGER) SIDE OPPOSITE-

SERVICE PARTS LIST

ITEM	PART NO.	QTY	DESCRIPTION
1	552074	1	REGAL 7 OVAL STEP, LH,96",477097, EXT CAB
2	552075	1	REGAL 7 OVAL STEP, RH,96",477097, EXT CAB
1	552076	1	REGAL 7 OVAL STEP, LH,100",477101, EXT CAB
2	552077	1	REGAL 7 OVAL STEP, RH,100",477101, EXT CAB
1	552078	1	REGAL 7 OVAL STEP, LH,112",477113, EXT CAB
2	552079	1	REGAL 7 OVAL STEP, RH,112",477113, EXT CAB
1	552080	1	REGAL 7 OVAL STEP, LH,100",477102, CREW CAB
2	552081	1	REGAL 7 OVAL STEP, RH,100",477102, CREW CAB
1	552501	1	REGAL 7 OVAL STEP, LH, 106",477108, CREW CAB
2	552502	1	REGAL 7 OVAL STEP, RH, 106",477108, CREW CAB
1	552082	1	REGAL 7 OVAL STEP, LH,112",477114, CREW CAB
2	552083	1	REGAL 7 OVAL STEP, RH,112",477114, CREW CAB
1	552084	1	REGAL 7 OVAL STEP, LH,123",477125, CREW CAB
2	552085	1	REGAL 7 OVAL STEP, RH,123",477125, CREW CAB
3	109233	2	END CAP LH REAR, RH FRONT,BLK PLASTIC
4	109232	2	END CAP RH REAR, LH FRONT,BLK PLASTIC
5	107863	8	BOLT-CARRAIGE, 10-24 X 0.50,SST, BLACK
6	108909	6	STEP PAD, 25" X 6.5", PLASTIC, BLACK
7	108908	36	BOLT-CARRAIGE, 10-24 X 1.0,SST, BLACK
8	107864	44	NUT-NYLOCK, 10-24, SST
9	552052	10	SUPPORT MTG PLT, 11 GA, GALV
10	106997	20	SCREW-HEX HD, 5/16-18X1.0,SST,BLACK
11	106998	20	WSHR-FLAT, 5/16, SST, BLACK
12	102680	20	NUT-SER FLG, 5/16-18, SST
13	108913	2	STEP PAD, 15" X 6.5", PLASTIC (IF NEEDED)



(A LIVERNE Company)

1200 E. Birch St.

Brandon, SD 57005

REV B 06JUN14

REV A 31JUL12

552088 SHEET 2 OF 3 07MAY12

SERVICE PARTS LIST

- MODEL NO. - 477097
 - 477101
 - 477102
 - 477108
 - 477113
 - 477114
 - 477125

NOTE:
 SOME APPLICATIONS WILL
 USE A SMALL STEP PAD
 FOR THE BOX STEP.

