

INSTALLATION INSTRUCTIONS AND PARTS LIST

MODELS:

477097, 477101, 477113 (EXTENDED CABS)
477102, 477108, 477114, 477125 (CREW CABS)
REGAL 7 OVAL STEPS (BOARDS ONLY)
UNIVERSAL APPLICATIONS



1. Read instructions completely and check to make sure that all required parts (listed on the service parts list) are on hand before starting the installation.
2. Follow the instructions included with the specific bracket package that you are using to mount the brackets to your vehicle.
3. The step is pre-assembled from the factory. The serial number label is located on the front inside drivers side step assembly.
4. Attaching the step to the mounting bracket:
 - 4.1 Set the step on the mounting brackets, and slide each support mounting plate (item #9) inside the oval step and above each bracket.
 - 4.2 Using the supplied 5/16-18 x 1" black stainless steel hex bolt, washer, and serrated flange nut (items # 10,11&12) attach the step assembly, support mounting plate and mounting bracket.
 - 4.3 Set the step plate in the correct position and tighten all fasteners.
Torque all 5/16" fasteners to 19 LB FT.

INSTALLATION INSTRUCTIONS AND PARTS LIST

APPLICATION:

MODEL 401117 WHEEL TO WHEEL STEP BRACKETS:

1999 GM SILVERADO & SIERRA REGULAR/EXTENDED/CREW CAB PICKUPS



1. READ INSTRUCTIONS COMPLETELY AND CHECK TO MAKE SURE THAT ALL REQUIRED PARTS (LISTED ON SERVICE PARTS LIST) ARE ON HAND BEFORE STARTING THE INSTALLATION.
2. ASSEMBLE THE LOAD REACTION STUDS AND HARDWARE (ITEM #8 THRU #11) AS FOLLOWS.
 - 2.1. ON THE SHORT THREADED END OF THE LOAD REACTION STUD (ITEM #11), INSTALL A BLACK 3/8" SERRATED FLANGE NUT (ITEM #10) BACKWARDS TO THE BOTTOM OF THE THREAD. THEN, INSTALL A BLACK 3/8" FLAT WASHER (ITEM #9) AND RUBBER "CUSHION" WASHER (ITEM #8) TIGHT UP AGAINST THE SERRATED FLANGE NUT. (THE END OF THE STUD MUST BE RECESSED IN THE RUBBER WASHER APPROX. 3/16").
 - 2.2. ON THE LONG THREADED END OF THE STUD, INSTALL A BLACK 3/8" SERRATED FLANGE NUT (ITEM #10) BACKWARDS TO NEAR TO THE BOTTOM OF THE THREADS
3. ATTACH THE LOAD REACTION STUD ASSEMBLIES TO THE BODY MOUNTING BRACKETS AS SHOWN.

NOTE: IF YOU ARE MOUNTING THE STEPS ON A 1500 MODEL PICKUP, YOU MUST ATTACH BRACKET (ITEM #14) TO BRACKETS (ITEM #1 & 2) (SEE FIG 1.) IN ORDER TO USE THE LOAD REACTION STUD.

- 3.1. INSERT THE STUD, FROM THE INBOARD SIDE OF THE BRACKET THRU THE LOWEST HOLE IN THE BENT FLANGE THAT WILL ALLOW THE RUBBER WASHER TO SEAT FIRM AGAINST THE SIDE WALL OF THE FRAME. INSTALL A BLACK FLANGE NUT (ITEM #10) ON THE OUTBOARD END OF THE STUD (FINGER TIGHT ONLY).

NOTE:

DUE TO EXCESSIVE THREAD LOCKER IN THE BODY MOUNT BOLT AREA ON THE 2010+ GM SILVERADO/SIERRA, USE CAUTION WHEN REMOVING THE BODY MOUNT BOLTS TO REDUCE THE RISK OF CAUSING DAMAGE TO THE THREADED INSERTS INSIDE THE VEHICLE.

4. REMOVE THE FACTORY FRONT, CENTER, AND REAR BODY MOUNT BOLTS (ONE SIDE OF THE VEHICLE AT A TIME) AND INSTALL THE MOUNTING BRACKETS PER THE FOLLOWING INSTRUCTIONS.
 - 4.1. INSTALL THE FRONT MTG BRKT (ITEM #1 & #2) TO THE FRONT CAB MOUNT AS SHOWN (LEAVE THESE FASTENERS FINGER TIGHT).
 - 4.2. INSTALL THE CENTER MTG BRKT (ITEM #3 & #4) TO THE CENTER CAB MOUNT AS SHOWN (LEAVE THESE FASTENERS FINGER TIGHT).
 - 4.3. INSTALL THE REAR INBOARD MTG BRKT (ITEM #7) & WASHER (ITEM #13) TO THE REAR CAB MOUNT AS SHOWN (LEAVE THESE FASTENERS FINGER TIGHT) (EXTENDED AND CREW CAB ONLY).

INSTALLATION INSTRUCTIONS AND PARTS LIST

APPLICATION:

MODEL 401117 WHEEL TO WHEEL STEP BRACKETS:

1999 GM SILVERADO & SIERRA REGULAR/EXTENDED/CREW CAB PICKUPS

EXTENDED CAB ONLY

- 4.3.1. ATTACH THE REAR OUTBOARD CAB MTG BRKT (ITEM #5 & #6) TO THE REAR INBOARD CAB MTG BRKT (ITEM #7), WITH THE 3/8" BLACK ZINC PLATED BOLTS (ITEM # 12), WASHERS (ITEM #9) AND SERRATED FLANGE NUTS (ITEM # 10). THE REAR OUTBOARD CAB MTG BRKT MUST BE MOUNTED TO THE BACK SIDE OF THE REAR INBOARD CAB MTG BRKT (TOWARDS THE REAR OF THE VEHICLE) AS SHOWN. BE SURE TO USE THE BOTTOM SINGLE HOLE AND BOTTOM DOUBLE HOLES IN THE REAR INBOARD CAB MTG BRKT (SEE FIG 1). PUT THE BOLTS THROUGH THE FRONT SIDE OF THE BRACKET SO THE FLANGE NUTS ARE ON THE BACK SIDE TO ALLOW CLEARANCE FOR THE FRAME OF THE TRUCK. TORQUE THE BOLTS TO 19 LB. FT.

CREW CAB ONLY

- 4.3.2. INSTALL THE REAR OUTBOARD CAB MTG BRKT (ITEM #5 & #6) TO THE REAR INBOARD CAB MTG BRKT (ITEM #7), WITH THE 3/8" BLACK ZINC PLATED BOLTS (ITEM # 12), WASHERS (ITEM #9) AND SERRATED FLANGE NUTS (ITEM # 12). THE REAR OUTBOARD CAB MTG BRKT MUST BE MOUNTED TO THE BACK SIDE OF THE REAR INBOARD CAB MTG BRKT (TOWARDS THE REAR OF THE VEHICLE) AS SHOWN. BE SURE TO USE THE BOTTOM SINGLE HOLE AND TOP DOUBLE HOLES IN THE REAR INBOARD CAB MTG BRKT (SEE FIG 1). PUT THE BOLTS THROUGH THE FRONT SIDE OF THE BRACKET SO THE FLANGE NUTS ARE ON THE BACK SIDE TO ALLOW CLEARANCE FOR THE FRAME OF THE TRUCK. TORQUE THE BOLTS TO 19 LB. FT.
5. ATTACH THE SPRING HANGER MOUNTING BRACKETS (ITEM # 22 & #23) AGAINST THE SIDE OF THE VEHICLE SPRING HANGER AS SHOWN
 - 5.1. LOOSEN THE SPRING HANGER BOLT JUST ENOUGH SO THAT THE INBOARD SPRING HANGER MTG BRKT (ITEM #23) CAN BE SLID UP BEHIND THE FLANGE OF THE BOLT. POSITION THE INBOARD SPRING HANGER MTG BRKT BEHIND THE FLANGE OF THE SPRING HANGER BOLT, WITH THE CHANNEL OPEN TO THE OUTBOARD SIDE, AS SHOWN.
 - 5.2. INSTALL THE OUTBOARD SPRING HANGER MTG BRKT (ITEM #22) SO THAT THE INBOARD VERTICAL PORTION OF THE BRACKET FITS INSIDE THE CHANNEL SHAPE OF THE INBOARD SPRING HANGER MTG BRKT USING THE 3/8" ZINC PLATED BOLT (ITEM #20), 3/8" WASHER (ITEM #21), 1/2" WASHER (ITEM #18), AND 3/8" ZINC PLATED NYLOCK NUT (ITEM #19) AS SHOWN. DO NOT TIGHTEN THESE BOLTS UNTIL THE BRACKET IS ATTACHED TO THE STEP ASSEMBLY.
6. ATTACHING THE STEP ASSEMBLY:
PLEASE REVIEW THE INSTALLATION INSTRUCTIONS THAT ARE INCLUDED IN YOUR STEP ASSEMBLY FOR SPECIFIC DETAILS

TIGHTEN THE BODY MOUNT BOLTS PER MANUFACTURERS SPECS.

TIGHTEN THE SPRING HANGER BOLT PER MANUFACTURERS SPECS



(A LUVERNE Company)

INSTALLATION INSTRUCTIONS AND PARTS LIST

APPLICATION:

MODEL 401117 WHEEL TO WHEEL STEP BRACKETS:

1999 GM SILVERADO & SIERRA REGULAR/EXTENDED/CREW CAB PICKUPS

SERVICE PARTS LIST

ITEM	PART NO.	QTY	DESCRIPTION
PARTS INCLUDED IN BRACKET PACKAGE			
1	551868	1	BRACKET-MTG, CAB, FRONT, LH, 401117
2	551869	1	BRACKET-MTG, CAB, FRONT, RH, 401117
3	551870	1	BRACKET-MTG, CAB,CENTER, LH, 401117
4	551871	1	BRACKET-MTG, CAB, CENTER, RH, 401117
5	551890	1	BRACKET-MTG, CAB, REAR, OUTBOARD, LH, 401117
6	551891	1	BRACKET-MTG, CAB, REAR, OUTBOARD, RH, 401117
7	551907	2	BRACKET-MTG, CAB, REAR, INBOARD, LH/RH, 401117
8	102592	6	WSHR, RUBBER, .354 ID X 1.00 OD X .75 THK
9	106962	12	WSHR, FL, 3/8", .438 ID X 1.00 OD X .083" THK, BZP
10	106995	24	NUT, SERR FLG, HEX, 3/8-16 UNC, BZP
11	106960	6	STUD, -DBL ENDED, STL, 3/8-16 X 4.50", BZP
12	106963	6	BOLT, 3/8-16X1.00, BZP
13	108882	2	WSHR, FL, .59 ID X 1.06 OD X .19 THK, ZP
14	551571	2	BRKT, 90 DEGREE, 3 HOLES
15	106997	2	SCREW, HHC, 5/16-18X1.00, BZP
16	106996	2	NUT-SERR FLG, 5/16-18, BZP
17	106998	2	WSHR-FL,SST,5/16",BZP
18	100118	4	WASHER-FL, 1/2", ZP
19	102381	2	NUT-NYLOCK, HEX, 3/8-16, ZP
20	101326	2	BOLT, HEX HEAD, 3/8-16X2.00, ZP
21	100062	4	WASHER-FL, 3/8", ZP
22	551892	2	BRACKET-MTG, SPRING HANGER, OUTBOARD, 401117
23	551806	2	BRACKET-MTG, SPRING HANGER, INBOARD, 401117



(A LUVERNE Company)

SERVICE PARTS LIST

MODEL NO. -401117

CREW CAB

EXT CAB

USE THESE HOLE LOCATIONS

USE THESE HOLE LOCATIONS

POSITION RUBBER WASHER AGAINST SIDE OF FRAME

FIG. 1

REAR INBOARD

LH & RH 7

5 LH REAR OUTBOARD
6 RH REAR OUTBOARD

3 LH CENTER (SHOWN)
4 RH CENTER

1 LH FRONT (SHOWN)
2 RH FRONT

FRONT

#14-17 ARE USED
ON 1500 MODELS ONLY

EXISTING BODY MOUNT BOLTS
TORQUE PER INSTRUCTION



LEFT (DRIVER) SIDE SHOWN
-RIGHT (PASSENGER) SIDE OPPOSITE-

SERVICE PARTS LIST

ITEM	PART NO.	QTY	DESCRIPTION
1	552074	1	REGAL 7 OVAL STEP, LH,96",477097, EXT CAB
2	552075	1	REGAL 7 OVAL STEP, RH,96",477097, EXT CAB
1	552076	1	REGAL 7 OVAL STEP, LH,100",477101, EXT CAB
2	552077	1	REGAL 7 OVAL STEP, RH,100",477101, EXT CAB
1	552078	1	REGAL 7 OVAL STEP, LH,112",477113, EXT CAB
2	552079	1	REGAL 7 OVAL STEP, RH,112",477113, EXT CAB
1	552080	1	REGAL 7 OVAL STEP, LH,100",477102, CREW CAB
2	552081	1	REGAL 7 OVAL STEP, RH,100",477102, CREW CAB
1	552501	1	REGAL 7 OVAL STEP, LH, 106",477108, CREW CAB
2	552502	1	REGAL 7 OVAL STEP, RH, 106",477108, CREW CAB
1	552082	1	REGAL 7 OVAL STEP, LH,112",477114, CREW CAB
2	552083	1	REGAL 7 OVAL STEP, RH,112",477114, CREW CAB
1	552084	1	REGAL 7 OVAL STEP, LH,123",477125, CREW CAB
2	552085	1	REGAL 7 OVAL STEP, RH,123",477125, CREW CAB
3	109233	2	END CAP LH REAR, RH FRONT,BLK PLASTIC
4	109232	2	END CAP RH REAR, LH FRONT,BLK PLASTIC
5	107863	8	BOLT-CARRAIGE, 10-24 X 0.50,SST, BLACK
6	108909	6	STEP PAD, 25" X 6.5", PLASTIC, BLACK
7	108908	36	BOLT-CARRAIGE, 10-24 X 1.0,SST, BLACK
8	107864	44	NUT-NYLOCK, 10-24, SST
9	552052	10	SUPPORT MTG PLT, 11 GA, GALV
10	106997	20	SCREW-HEX HD, 5/16-18X1.0,SST,BLACK
11	106998	20	WSHR-FLAT, 5/16, SST, BLACK
12	102680	20	NUT-SER FLG, 5/16-18, SST
13	108913	2	STEP PAD, 15" X 6.5", PLASTIC (IF NEEDED)



SERVICE PARTS LIST

- MODEL NO. - 477097
 - 477101
 - 477102
 - 477108
 - 477113
 - 477114
 - 477125

NOTE:
 SOME APPLICATIONS WILL
 USE A SMALL STEP PAD
 FOR THE BOX STEP.

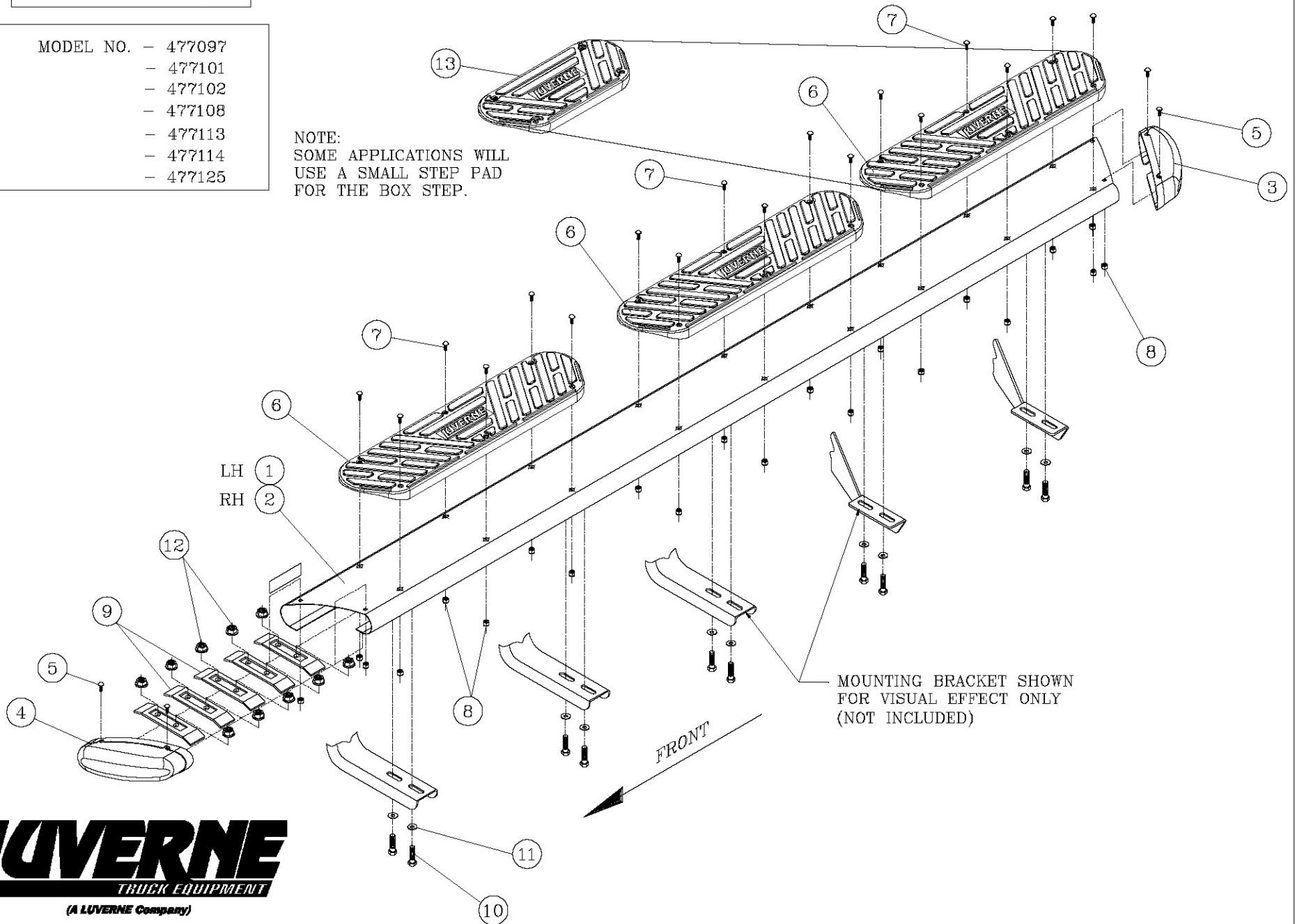

Choose reliable running boards offered on our website.