

INSTALLATION INSTRUCTIONS AND PARTS LIST
MODEL 477054, 477060 REGAL 7 OVAL STEPS (BOARDS ONLY)
UNIVERSAL APPLICATIONS



1. Read instructions completely and check to make sure that all required parts (listed on the service parts list) are on hand before starting the installation.
2. Follow the instructions included with the specific bracket package that you are using to mount the brackets to your vehicle. The serial number label is located on the front inside drivers side step assembly.
3. The step is pre-assembled from the factory. The serial number label is located on the front inside drivers side step assembly.
- 4.
5. Attaching the step to the mounting bracket:
 - 4.1 Set the step on the mounting brackets, and slide each support mounting plate (item #9) inside the oval step and above each bracket.
 - 4.2 Using the supplied 5/16-18 x 1" black stainless steel hex bolt, washer, and serrated flange nut (items # 10,11&12) attach the step assembly, support mounting plate and mounting bracket.
 - 4.3 Set the step plate in the correct position and tighten all fasteners.
Torque all 5/16" fasteners to 19 LB FT.

SERVICE PARTS LIST

ITEM	PART NO.	QTY	DESCRIPTION
1&2	552054	2	REGAL 7 OVAL STEP, LH,RH,52",477054
1&2	552055	2	REGAL 7 OVAL STEP, LH,RH,58",477060
3	109233	2	END CAP LH REAR, RH FRONT,BLK PLASTIC
4	109232	2	END CAP RH REAR, LH FRONT,BLK PLASTIC
5	107863	8	BOLT-CARRAIGE, 10-24 X 0.50,SST, BLACK
6	108909	2	STEP PAD, 25" X 6.5", PLASTIC, BLACK
7	108908	12	BOLT-CARRAIGE, 10-24 X 1.0,SST, BLACK
8	107864	12	NUT-NYLOCK, 10-24, SST
9	552052	6	SUPPORT MTG PLT, 11 GA, GALV
10	106997	12	SCREW-HEX HD, 5/16-18X1.0,SST,BLACK
11	106998	12	WSHR-FLAT, 5/16, SST, BLACK
12	102680	12	NUT-SER FLG, 5/16-18, SST



SERVICE PARTS LIST

MODEL NO. - 477054
- 477060

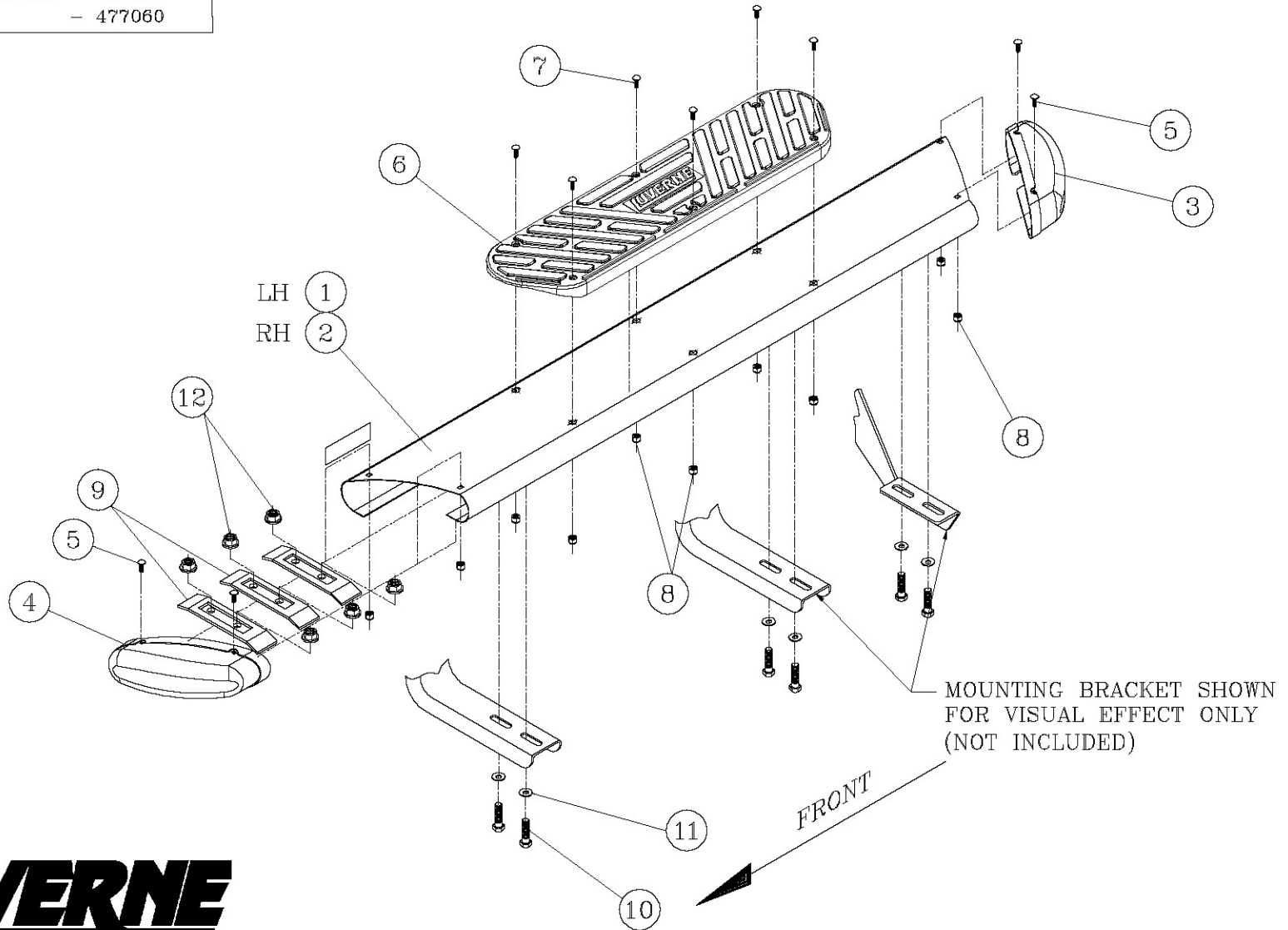

LUPERNE
TRUCK EQUIPMENT
(A LUPERNE Company)

INSTALLATION INSTRUCTIONS AND PARTS LIST

APPLICATION: **MODEL 401631 REGAL 7/GRIP STEP BRACKET KIT:**

2009+ DODGE RAM 1500 REGULAR CAB PICKUPS

2010+ DODGE RAM HD REGULAR CAB PICKUPS, & CHASSIS CABS.

1. READ INSTRUCTIONS COMPLETELY AND CHECK TO MAKE SURE THAT ALL REQUIRED PARTS (LISTED ON THE SERVICE PARTS LIST) ARE ON HAND BEFORE STARTING THE INSTALLATION.
2. ATTACH THE MOUNTING BRACKETS TO THE VEHICLE AS FOLLOWS:

RAM TRUCKS WITH THREADED INSERTS IN THE ROCKER PANEL.

- 2.1 PLACE THE DRIVERS SIDE FRONT BRACKET (ITEM #1) UP TO THE PINCHWELD SO THAT THE LOWER MOUNTING FLANGE IS TO THE OUTSIDE OF THE PINCHWELD, ALIGN THE TWO RECTANGULAR HOLES OF THE LOWER MOUNTING FLANGE OF (ITEM #1) WITH THE TWO OBOUND HOLES IN THE PINCHWELD, INSERT THE TWO 1/4-20 X 1" CARRIAGE BOLTS (ITEM #3) THROUGH THE LOWER MOUNTING FLANGE AND THEN THROUGH THE PINCHWELD, PLACE A 1/4" FLAT WASHER (ITEM #4), AND 1/4-20 FLANGE NUT (ITEM #5) ON TO THE CARRIAGE BOLTS, LEAVE FINGER TIGHT. **SEE FIGURES 1 & 2.**
- 2.2 INSERT AN M8 X 25mm SCREW (ITEM # 6) WITH A 5/16" FLAT WASHER (ITEM #7) THROUGH THE SLOTS ON THE UPPER MOUNTING FLANGE, LEAVE FINGER TIGHT.
- 2.3 REPEAT STEPS 2.1 & 2.2 ON THE REAR (ITEM #2) BRACKETS.
- 2.4 FOR THE PASSENGER SIDE THE INSTALLATION IS A MIRROR IMAGE OF THE DRIVERS SIDE, USE (ITEM #2) FOR THE FRONT BRACKET, & (ITEM #1) FOR THE REAR BRACKET.

RAM TRUCKS WITHOUT THREADED INSERTS IN THE ROCKER PANEL.

- 2.5 ON THE VERTICAL WALL OF THE ROCKER PANEL, INSTALL THE T-BOLT WELDMENT (ITEM #9) INTO THE LARGE OBOUND HOLE INSERTING THE NUT END FIRST, LEAVING THE THREADED STUD STICKING OUT OF THE OBOUND HOLE. **BE CAREFULL NOT TO DROP THE T-BOLT INSIDE OF THE ROCKER PANEL.** ATTACH THE FLAT PLASTIC BOLT RETAINER (ITEM #10) TO THE THREADED STUD OF THE T-BOLT. (THIS IS TO KEEP THE T-BOLT FROM FALLING INTO THE ROCKER PANEL.)
- 2.6 PLACE THE DRIVERS SIDE FRONT BRACKET (ITEM #1) UP TO THE PINCHWELD SO THAT THE LOWER MOUNTING FLANGE IS TO THE OUTSIDE OF THE PINCHWELD, ALIGN THE TWO RECTANGULAR HOLES OF THE LOWER MOUNTING FLANGE OF (ITEM #1) WITH THE TWO OBOUND HOLES IN THE PINCHWELD, INSERT THE TWO 1/4-20 X 1" CARRIAGE BOLTS (ITEM #3) THROUGH THE LOWER MOUNTING FLANGE AND THEN THROUGH THE PINCHWELD, PLACE A 1/4" FLAT WASHER (ITEM #4), AND 1/4-20 FLANGE NUT (ITEM #5) ON TO THE CARRIAGE BOLTS, LEAVE FINGER TIGHT. **SEE FIGURES 3 & 4.**
- 2.7 PLACE A FLAT WASHER (ITEM #7), AND AN M8 FLANGE NUT (ITEM #8), ON THE THREADED STUD OF THE T-BOLT (ITEM #9) LEAVE FINGER TIGHT.
- 2.8 ROTATE THE T-BOLT SO THAT THE THREADED NUT IS VISIBLE THROUGH THE SLOTTED HOLE IN THE UPPER MOUNTING FLANGE, INSERT AN M8 X 25mm SCREW (ITEM #6) WITH A 5/16" FLAT WASHER (ITEM #7), LEAVE FINGER TIGHT.
- 2.9 REPEAT STEPS 2.5 THRU 2.8 ON THE REAR (ITEM #2) BRACKETS.
- 2.10 FOR THE PASSENGER SIDE THE INSTALLATION IS A MIRROR IMAGE OF THE DRIVERS SIDE, USE (ITEM #2) FOR THE FRONT BRACKET, & (ITEM #1) FOR THE REAR BRACKET.

NOTE: 2009 TO 2012 TRUCKS DO NOT HAVE THE OBOUND HOLES IN THE PINCH WELD, THEY WILL REQUIRE DRILLING (2) 5/16" HOLES FOR EACH BRACKET, TO GET THE PROPER LOACTION FOR DRILLING FOLOW STEP 2.5, AND THEN SKIP TO STEP 2.7 & 2.8, WITH THE BRACKET IN PLACE, NOW MARK THE PINCHWELD FOR DRILLING.

3. INSTALL THE STEP PLATES, AND ADJUST BRACKETS, AND BOARDS BEFORE TIGHTENING ALL THE FASTENERS.



SERVICE PARTS LIST

ITEM	PART NO.	QTY	DESCRIPTION
1	553006	2	BRKT-MTG, WLDMNT, FRONT LH, 401632
2	553007	2	BRKT-MTG, WLDMNT, FRONT RH, 401632
3	101320	8	BLT-CRG, 1/4-20 X 1.00", SST, BLK, EM6219
4	101370	8	WSHR-FL, SST, .281 X .625 X .065
5	102366	8	NUT-FLG, HEX, 1/4-20, SST
6	102549	8	SCR-HEX HD, M8 X 1.25 X 25mm, ZP
7	100034	8	WSHR-FL, 5/16, ZP
8	105859	4	NUT HEX-FLG, M8 X 1.25, ZP
9	553012	4	T-BOLT WELDMENT, ZP, 571632
10	101572	4	BOLT RETAINER-PLASTIC, 8mm

SERVICE PARTS LIST

BRACKET NO. - 401631

Fig.1

INSTALLATION ON ROCKER
PANELS WITH THREADED
INSERTS

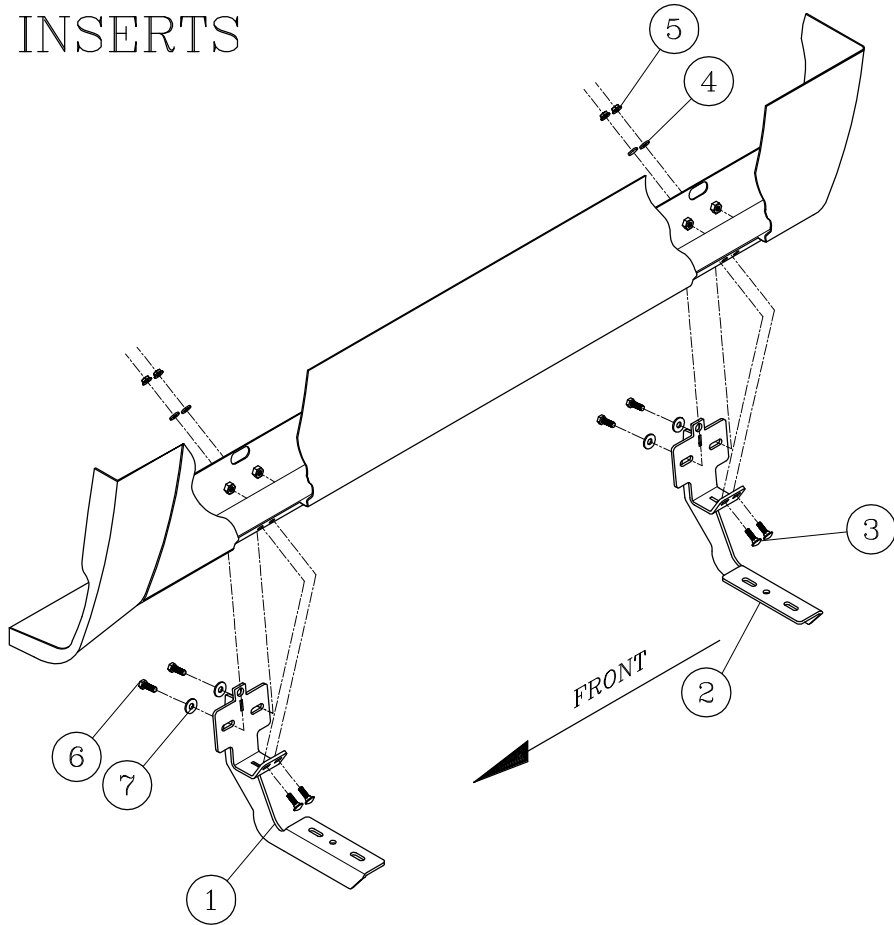

LEFT (DRIVER) SIDE SHOWN
-RIGHT (PASSENGER) SIDE OPPOSITE-

Fig.2

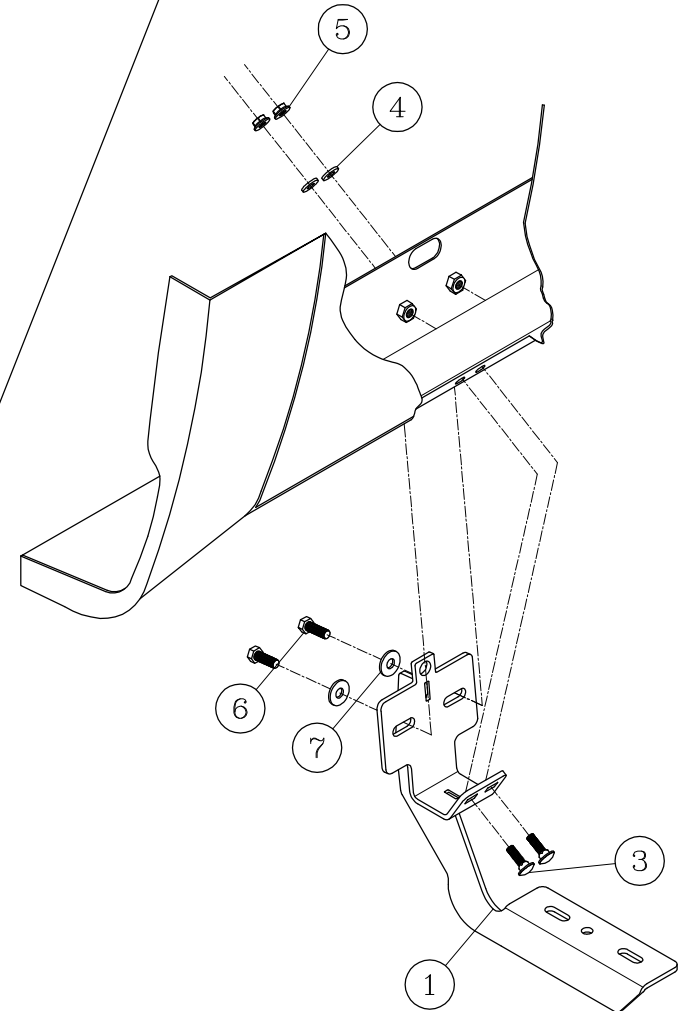

SERVICE PARTS LIST

BRACKET NO. - 401631

Fig.3

INSTALLATION ON ROCKER
PANELS WITHOUT
THREADED INSERTS

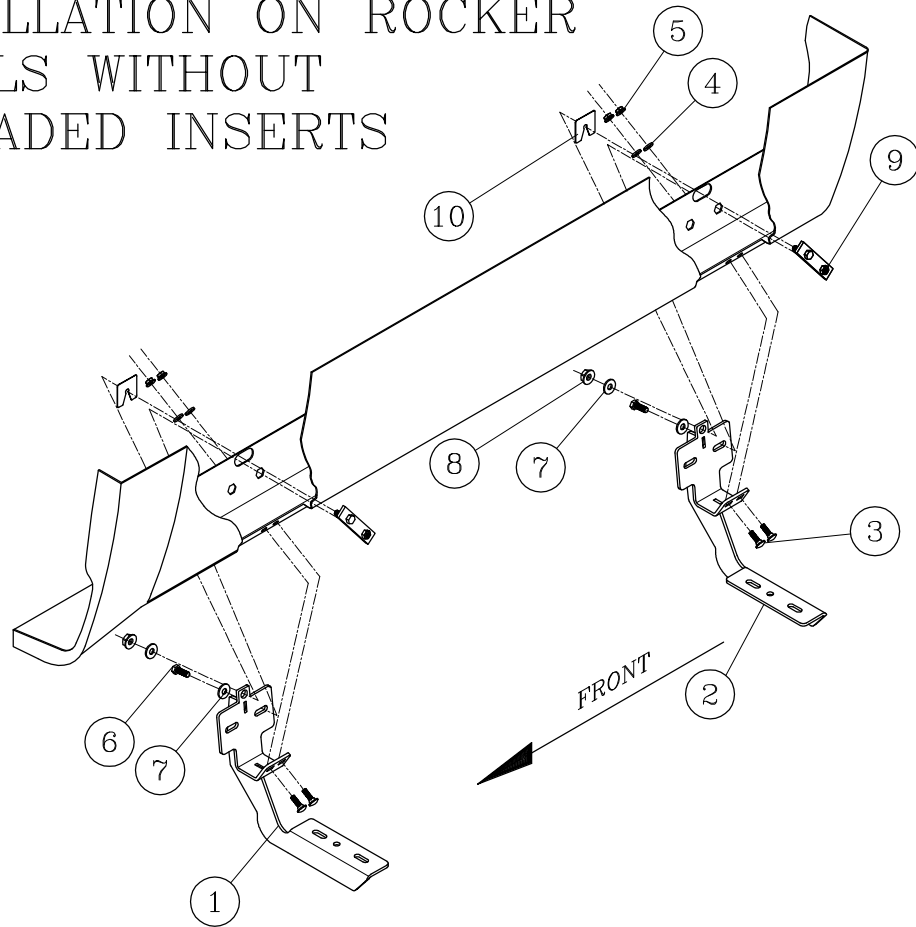

LEFT (DRIVER) SIDE SHOWN
-RIGHT (PASSENGER) SIDE OPPOSITE-

Fig.4

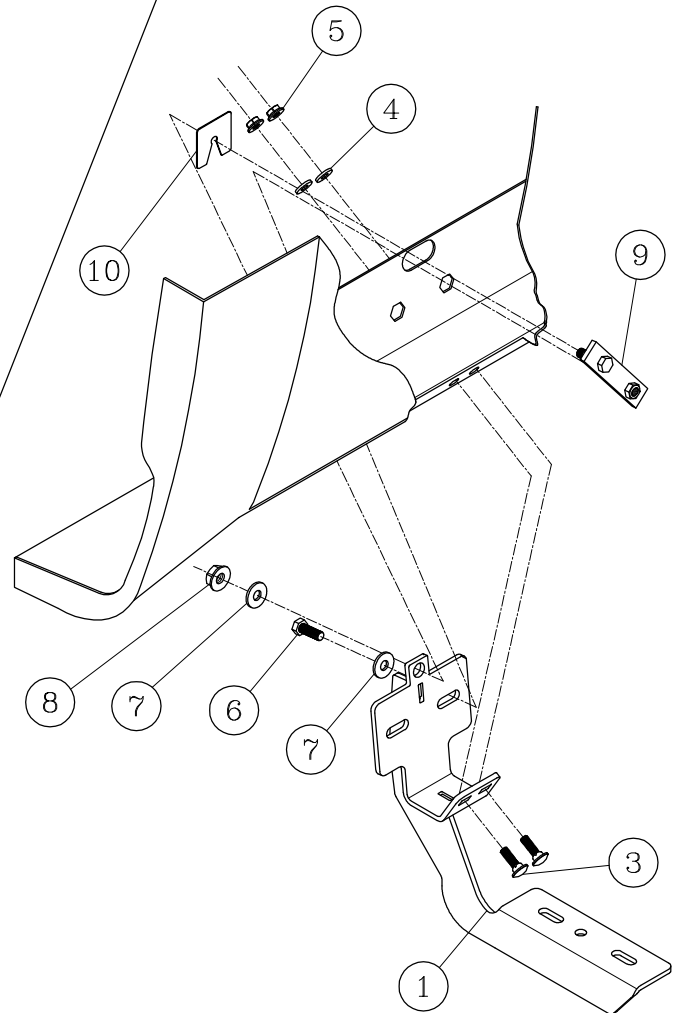

NOTE: 2009-12 WILL REQUIRE DRILLING THESE HOLES IN THE PINCHWELD.

