

INSTALLATION INSTRUCTIONS AND PARTS LIST

MODEL 415114, GRIP STEPS (BOARDS ONLY)

UNIVERSAL APPLICATIONS

1. Read instructions completely and check to make sure that all required parts (listed on the service parts list) are on hand before starting the installation.
2. Follow the instructions included with the specific bracket package to mount the brackets to your vehicle.
3. Step assembly:
 - 3.1 This Board can be modified from its original length to fit many applications. Simply determine how long you will need the board, and cut to that length using a saber saw, chop saw, or hack saw. Use flat black paint to touch up the ends that were cut.
 - 3.2 Before attaching the grip steps to the brackets, slide the appropriate number of support braces (item #2) into the channel of the step (item #1).
 - 3.3 Slide the end cap (item #3) over the front and rear of each step. Using the supplied #8 x 1/2" self drilling tek screw (item #8), screw the end cap to the bottom of the step.
4. Attaching the step to the mounting bracket:
 - 4.1 Set the step on the mounting brackets, and slide each support brace over the top of each mounting bracket. Attach the flat spacer plate (item #4) to the bottom of the step, between the support brace, and the top of the mounting bracket.
 - 4.2 Using the supplied 5/16-18 x 1" carriage bolt, washer, and flange nuts, (item #5, 6, 7), attach the step assembly, flat spacer plate and mounting bracket. **(NOTE: Some of the flange nuts are supplied in the specific bracket package, not the step package.)**
 - 4.3 Set the step plate in the correct position and tighten all fasteners.
Torque all fasteners to 19 LB FT.

SERVICE PARTS LIST

ITEM	PART NO.	QTY	DESCRIPTION
1	551888	2	EXTRUSION-AL,97.87,GRIP STEP,BLK,415098
1	551889	2	EXTRUSION-AL,101.25,GRIP STEP,BLK,415102
1	551388	2	EXTRUSION-AL,113.62,GRIP STEP,BLK,415114
2	551296	10	SUPPORT BRACE, UPPER, GALV.
3	551394	4	CAP-END,GRIP STEP, BLACK, PLASTIC
4	551298	14	SPACER PLATE, LOWER, BLACK
5	108683	20	BOLT-CRG,5/16-18 X 1.0", SST
6	101369	20	WASHER-FLAT,5/16,SST
7	102680	20	NUT-SERR FLG,HX,SST,WX,5/16-18
8	107958	8	SCR-TEK #8-18 X 1/2",SST,BLK



SERVICE PARTS LIST

MODEL NO. - 415098
415102
415114

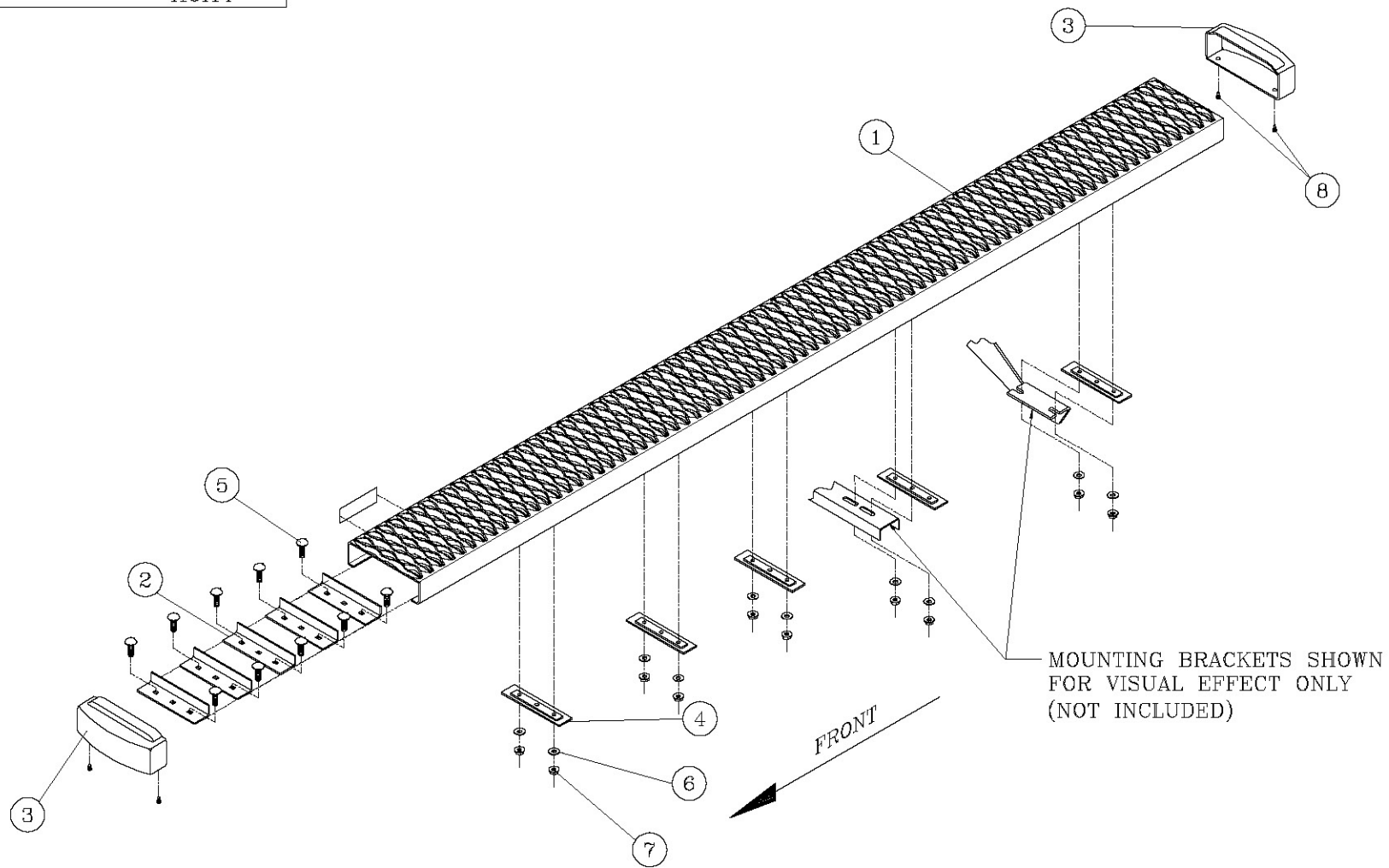

INSTALLATION INSTRUCTIONS AND PARTS LIST

APPLICATION: MODEL 571439/401439 W2W MEGA/GRIP STEP BRACKETS ON:
2014+ RAM 2500 PICKUPS



1. READ INSTRUCTIONS COMPLETELY AND CHECK TO MAKE SURE THAT ALL REQUIRED PARTS (LISTED ON SERVICE PARTS LIST) ARE ON HAND BEFORE STARTING THE INSTALLATION.

NOTE: FOR REGULAR CAB PICKUPS ONLY THE FRONT AND REAR CAB MOUNTING BRACKETS ARE USED, THE CENTER MOUNTING BRACKET AND FASTENERS MAY BE DISCARDED.

2. ASSEMBLE THE LOAD REACTION STUDS AND HARDWARE AS FOLLOWS.

NOTE: USE A 4" STUD (ITEM #19) FOR THE FRONT BRACKET AND A 3" STUD (ITEM #18) FOR THE REAR BRACKETS.

- 2.1. ON THE SHORT THREADED END OF THE LOAD REACTION STUD (ITEM #18, 19), INSTALL A 3/8" SERRATED FLANGE NUT (ITEM #17) BACKWARDS TO THE BOTTOM OF THE THREAD. THEN INSTALL A 3/8" FLAT WASHER (ITEM #16) AND RUBBER "CUSHION" WASHER (ITEM # 15) TIGHT UP AGAINST THE SERRATED FLANGE NUT. (THE END OF THE STUD MUST BE RECESSED IN THE RUBBER WASHER APPROX. 3/16").
 - 2.2. ON THE LONG THREADED END OF THE STUD, INSTALL A 3/8" SERRATED FLANGE NUT (ITEM # 17) BACKWARDS TO NEAR TO THE BOTTOM OF THE THREADS
3. ATTACH THE LOAD REACTION STUD ASSEMBLIES TO THE MOUNTING BRACKETS AS SHOWN. INSERT THE STUD, FROM WHAT WILL BE THE INBOARD OR FRAME SIDE THRU THE LOWEST HOLE IN THE BENT FLANGE OF THE BRACKET THAT WILL ALLOW THE RUBBER WASHER TO SEAT FIRM AGAINST THE SIDE WALL OF THE FRAME. INSTALL A FLANGE NUT (ITEM #17) ON THE OUTBOARD END OF THE STUD (FINGER TIGHT ONLY).
 4. ON THE RIGHT SIDE OF THE VEHICLE, REMOVE THE FACTORY FRONT, CENTER, AND REAR BODY MOUNT BOLTS (ONE SIDE OF THE VEHICLE AT A TIME), THESE WILL NOT BE REUSED. INSTALL THE MOUNTING BRACKETS PER THE FOLLOWING INSTRUCTIONS:
 - 4.1. USING A M12 – 110MM BOLT (ITEM #12) AND A 2.0" WASHER (ITEM #14) INSTALL THE FRONT MOUNTING BRACKET (ITEM #1, 2) TO THE FRONT BODY MOUNT AS SHOWN (LEAVE THESE FASTENERS FINGER TIGHT).
 - 4.2. USING A M12 – 110MM BOLT (ITEM #12) AND A 2.0" WASHER (ITEM #14) INSTALL THE CENTER MOUNTING BRACKET (ITEM #3, 4) TO THE CENTER BODY MOUNT AS SHOWN (LEAVE THESE FASTENERS FINGER TIGHT).
 - 4.3. USING A M12 – 116MM BOLT (ITEM #13) AND A 1/2" FLAT WASHER (ITEM #21) INSTALL THE REAR MOUNTING BRACKET (ITEM #5, 6) TO THE REAR BODY MOUNT AS SHOWN (LEAVE THESE FASTENERS FINGER TIGHT). **NOTE: THE ORIENTATION OF THE REAR BRACKET WILL BE DIFFERENT BETWEEN THE REG/QUAD/CREW CAB PICKUPS AND THE MEGA CAB PICKUPS. IF INSTALLING ON A REG/QUAD/CREW CAB PICKUP REFER TO FIG. 1, IF INSTALLING ON A MEGA CAB PICKUP REFER TO FIG. 2.**
 - 4.4. ATTACH THE REAR OUTBOARD MOUNTING BRACKET (ITEM #7, 8) TO THE REAR INBOARD MOUNTING BRACKET (ITEM #5, 6) IN THE UPPER MOUNTING LOCATION, USING THREE 3/8-16 X 1.0" SCREW, 3/8" FLAT WASHERS AND 3/8" FLANGE NUTS. (ITEMS #16, 17, 20).



(A LUVERNE Company)

5. ATTACH THE MOUNTING BRACKETS TO THE SHACKLE MOUNT OF THE VEHICLE AS FOLLOWS.
 - 5.1. ATTACH THE UPPER MOUNTING BRACKET (ITEM #9) TO THE SIDE OF THE SUSPENSTION LINK HOUSING BY LOOSENING THE BOLT THAT FASTENS THE SUSPENSION LINKS TO THE VEHICLE. SLIDE THE UPPER MOUNTING BRACKET (ITEM #9) BETWEEN THE BOLT HEAD AND THE FRAME BRACKET. TIGHTEN DOWN THE BOLT MAKING SURE THAT THE UPPER MOUNTING BRACKET (ITEM #9) IS LEVEL.
 - 5.2. FASTEN THE LOWER BRACKET (ITEM #11) TO THE UPPER BRACKET (ITEM #9) USING 3/8 BOLT, WASHER AND NUT (ITEM #16, 17, 20) USING THE TWO LOWER HOLES IN THE UPPER BRACKET. MAKING SURE THAT IT SIT'S LEVEL TO THE FRONT BRACKETS.
6. ATTACH THE STEP PLATE PER THE INSTRUCTIONS INCLUDED WITH YOUR STEP PLATE ASSEMBLY.
7. POSITION THE LOAD REACTION STUD ASSY SO THAT THE RUBBER CUSHION IS SNUG UP AGAINST THE SIDE OF THE FRAME. TIGHTEN THE 3/8" FLANGE NUTS ON EITHER SIDE OF THE BRACKET TO 19LB. FT.

SERVICE PARTS LIST

ITEM	PART NO.	QTY	DESCRIPTION
1	552850	1	BRKT-MTG, MS, FRONT, LH, BODY MOUNT
1	552862	1	BRKT-MTG, GRIP, FRONT, LH, BODY MOUNT
2	552851	1	BRKT-MTG, MS, FRONT, RH, BODY MOUNT
2	552863	1	BRKT-MTG, GRIP, FRONT, RH, BODY MOUNT
3	552852	1	BRKT-MTG, MS, CENTER, LH, BODY MOUNT
3	552864	1	BRKT-MTG, GRIP CENTER, LH, BODY MOUNT
4	552853	1	BRKT-MTG, MS, CENTER, RH, BODY MOUNT
4	552865	1	BRKT-MTG, GRIP, CENTER, RH, BODY MOUNT
5	552854	1	BRKT-MTG, REAR, LH, INBOARD, BODY MOUNT
6	552855	1	BRKT-MTG, REAR, RH, INBOARD, BODY MOUNT
7	552856	1	BRKT-MTG, MSREAR, LH, OUTBOARD
7	552868	1	BRKT-MTG, GRIP, REAR, LH, OUTBOARD
8	552857	1	BRKT-MTG, MS, REAR, RH, OUTBOARD
8	552869	1	BRKT-MTG, GRIP, REAR, RH, OUTBOARD
9	552457	1	BRKT-MTG, MS, W2W, LH, INBOARD
9	552411	1	BRKT-MTG, GRIP, W2W, LH, INBOARD
10	552458	1	BRKT-MTG, MS, W2W, RH, INBOARD
10	552412	1	BRKT-MTG, GRIP, W2W, RH, INBOARD
11	551721	2	BRKT-MTG, MS, W2W, LH/RH, LOWER
11	552125	2	BRKT-MTG, GRIP, W2W, LH/RH, LOWER
12	103444	4	SCREW-HEX HEAD, M12 – 1.75 X 110MM, ZP
13	109451	2	SCREW-HEX HEAD, M12 – 1.75 X 160MM, YZP
14	105909	4	WSHR-FLAT, 2.0 X .509 X .179, ZP
15	102592	6	WSHR, RUBBER, .354 ID X 1.00 OD X .75 THK
16	100062	16	WSHR, FLAT, 3/8", .438 ID X 1.00 OD X .083" THK
17	100181	28	NUT, SERR FLG, HEX, 3/8-16 UNC, ZP
18	104697	4	STUD, STL, 3/8-16 X 3.00", ZP
19	104686	2	STUD, -DBL ENDED, STL, 3/8-16 X 4.00", ZP
20	100040	10	SCR-HEX HD, 3/8-16 X 1.0" UNC, ZP
21	100118	2	WASHER, FLAT, 1/2" ZP

SERVICE PARTS LIST

MODEL NO.-571439/401439

FIG. 1 CREW/QUAD CAB

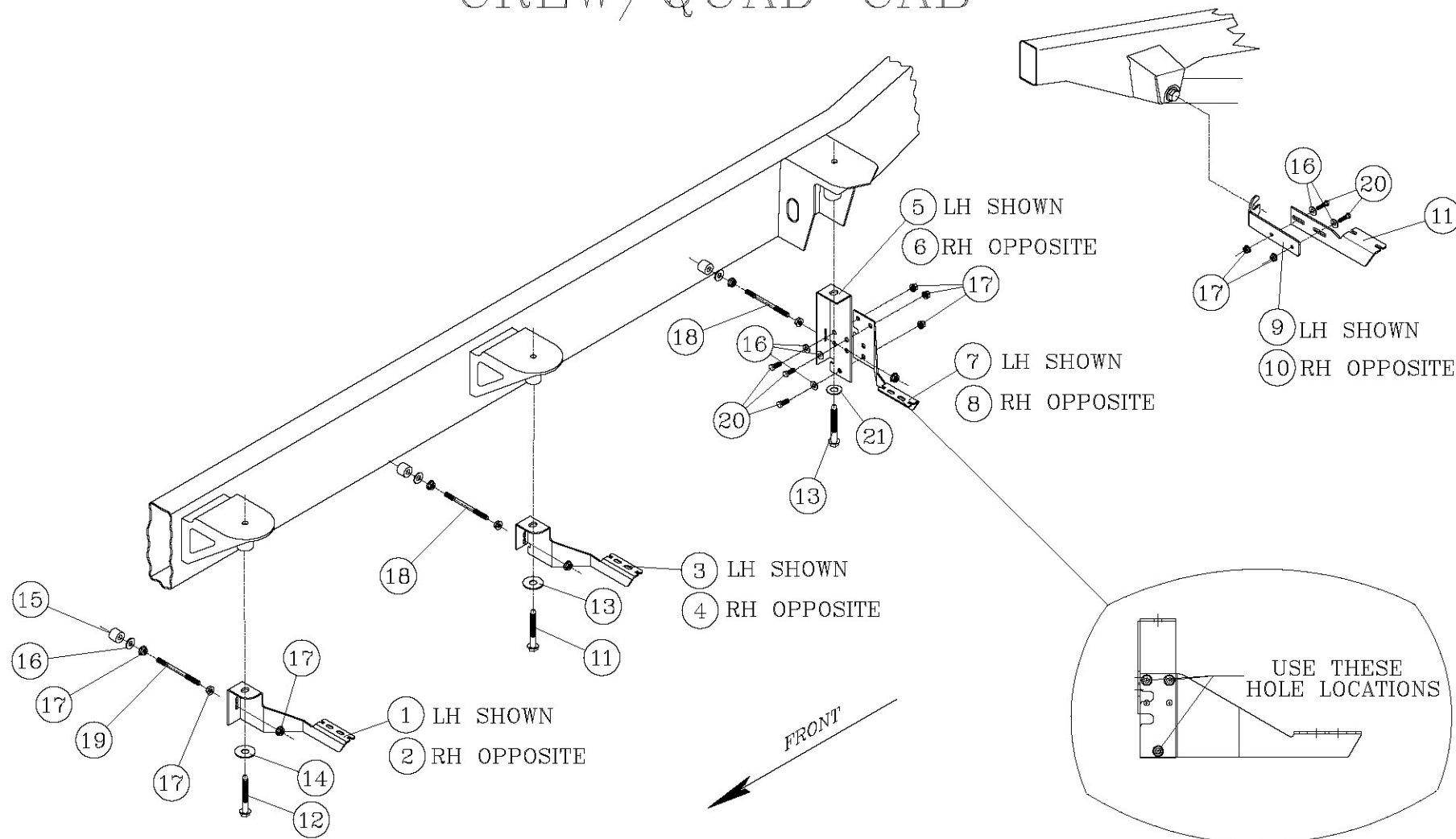

LEFT (DRIVER) SIDE SHOWN



LEFT (DRIVER) SIDE SHOWN
-RIGHT (PASSENGER) SIDE OPPOSITE-

SERVICE PARTS LIST

MODEL NO. -571439/401439

FIG. 2 MEGA CAB PICKUPS

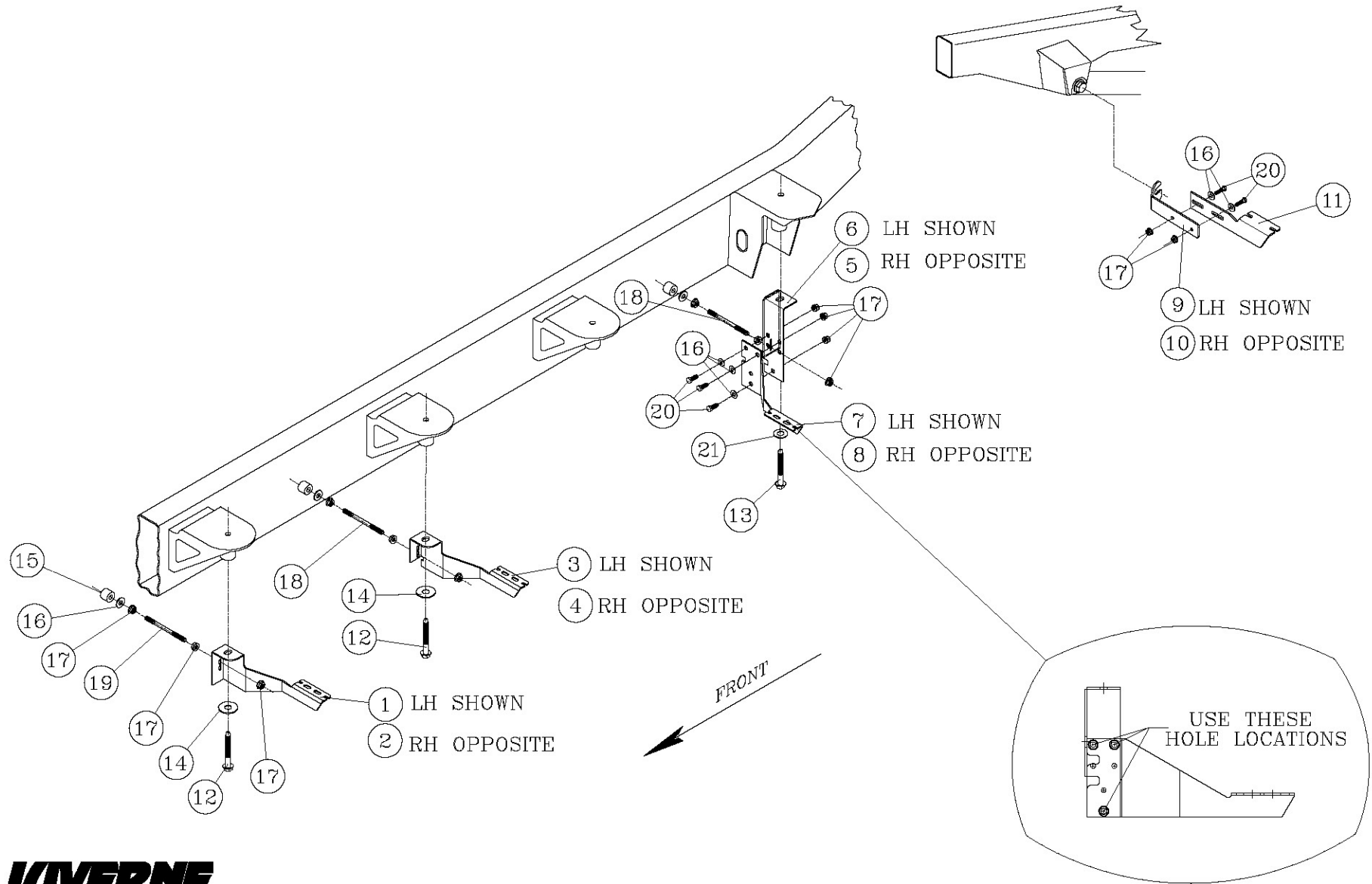

LEFT (DRIVER) SIDE SHOWN
-RIGHT (PASSENGER) SIDE OPPOSITE-

Choose reliable running boards offered on our website.