

INSTALLATION INSTRUCTIONS AND PARTS LIST

MODEL 415100, 36" & 98" GRIP STEPS (BOARDS ONLY)

1. READ INSTRUCTIONS COMPLETELY AND CHECK TO MAKE SURE THAT ALL REQUIRED PARTS (LISTED ON THE SERVICE PARTS LIST) ARE ON HAND BEFORE STARTING THE INSTALLATION.
2. FOLLOW THE INSTRUCTIONS INCLUDED WITH THE SPECIFIC BRACKET PACKAGE THAT YOU ARE USING TO MOUNT THE BRACKETS TO YOUR VEHICLE.
3. STEP ASSEMBLY:
 - 3.1 BEFORE ATTACHING THE GRIP STEPS TO THE BRACKETS, SLIDE THE APPROPRIATE NUMBERS OF SUPPORT BRACES (ITEM #2) INTO THE CHANNEL OF THE STEP (ITEM #1).
 - 3.2 SLIDE THE END CAP (ITEM #3) OVER THE FRONT AND REAR OF EACH STEP. USING THE SUPPLIED #8 X 1/2" SELF-DRILLING TEK SCREW (ITEM #8); SCREW THE END CAP TO THE BOTTOM OF THE STEP.
4. ATTACHING THE STEP TO THE MOUNTING BRACKETS:
 - 4.1 SET THE STEP ON THE MOUNTING BRACKETS, AND SLIDE EACH SUPPORT BRACE OVER THE TOP OF EACH MOUNTING BRACKET. ATTACH THE FLAT SPACER PLATE (ITEM #4) TO THE BOTTOM OF THE STEP, BETWEEN THE SUPPORT BRACE, AND THE TOP OF THE MOUNTING BRACKET.
 - 4.2 USING THE SUPPLIED 5/16-18 x 1" CARRIAGE BOLT, WASHER, AND FLANGE NUTS, (ITEM # 5, 6, 7), ATTACH THE STEP ASSEMBLY, FLAT SPACER PLATE AND MOUNTING BRACKET.
 - 4.3 SET THE STEP PLATE IN THE CORRECT POSITION AND TIGHTEN ALL FASTENERS. TORQUE ALL 5/16" FASTENERS TO 19 LB FT.

SERVICE PARTS LIST

ITEM	PART NO.	QTY	DESCRIPTION
1	551699	1	EXTRUSION-AL,36.00, GRIP STEP,BLK,415100
1	551888	1	EXTRUSION-AL,98.00,GRIP STEP,BLK,415100
2	551296	7	SUPPORT BRACE, UPPER, GALV
3	551394	4	CAP-END,GRIP STEP, BLACK, PLASTIC
4	551298	7	SPACER PLATE, LOWER, BLACK
5	108683	14	BOLT-CRG,5/16-18 X 1.0", SST
6	101369	14	WASHER-FLAT,5/16,SST
7	102680	14	NUT-SERR FLG,HX,SST,WX,5/16-18
8	107958	8	SCR-TEK #8-18 X 1/2",SST,BLK

LUPERNE
TRUCK EQUIPMENT

(A LUPERNE Company)

SERVICE PARTS LIST

MODEL NO. - 415100

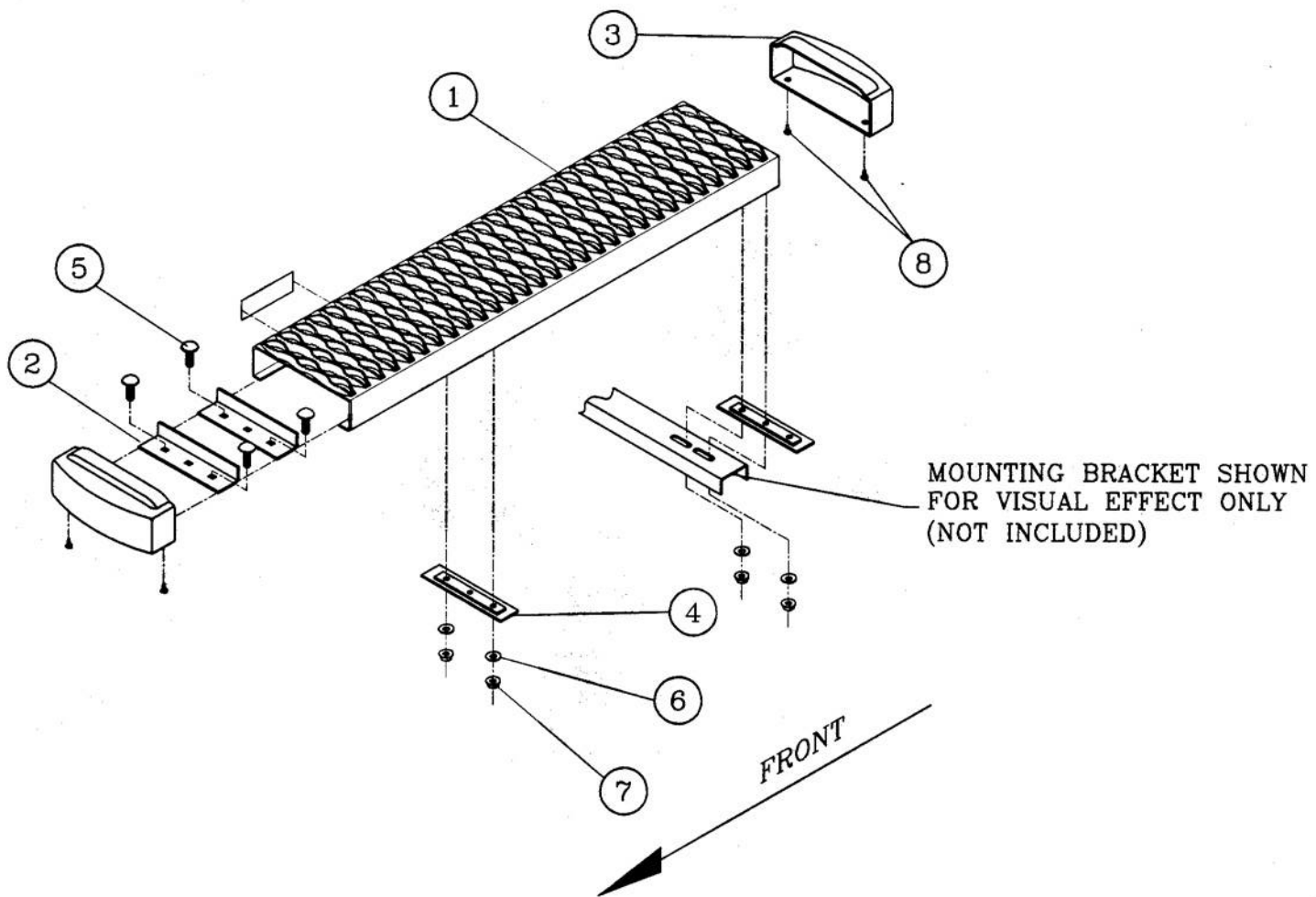

(A LIVERNE Company)

SERVICE PARTS LIST

MODEL NO. - 415100

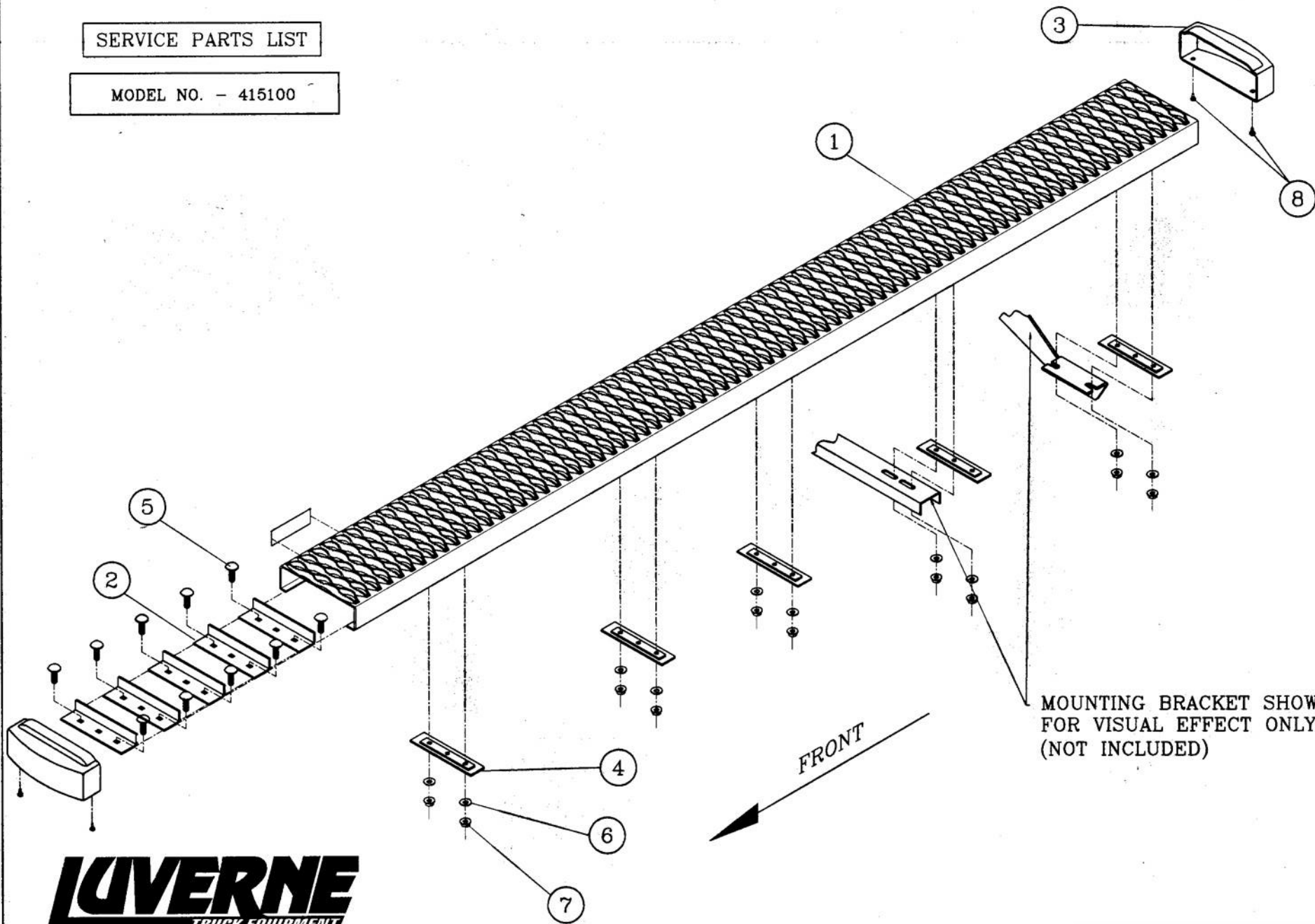

MOUNTING BRACKET SHOWN
FOR VISUAL EFFECT ONLY
(NOT INCLUDED)

LIVERNE
TRUCK EQUIPMENT

(A LIVERNE Company)

INSTALLATION INSTRUCTIONS AND PARTS LIST

MODEL 570124 BRACKET PACKAGE TO MOUNT O-MEGA STEPS/GRIP STEPS

VEHICLE APPLICATION:
2001 AND NEWER FORD VANS

READ INSTRUCTIONS COMPLETELY AND CHECK TO MAKE SURE THAT ALL REQUIRED PARTS (LISTED ON SERVICE PARTS LIST) ARE ON HAND BEFORE STARTING THE INSTALLATION.

1. ON THE PASSENGER SIDE OF THE VEHICLE, REMOVE THE TAPE THAT IS COVERING THE MOUNTING HOLES IN THE INSIDE QUARTER PANEL (FIVE LOCATIONS).
2. INSTALL THE SHORT 5/16-18" MULTI THREAD U-NUTS (ITEM #14) IN THE RECTANGULAR AND ROUND HOLES AT THE 1ST, 3RD, 4TH, & 5TH HOLES FROM THE FRONT. INSTALL THE LONG 5/16-18" MULTI THREAD U-NUT (ITEM #15) IN THE RECTANGULAR AND ROUND HOLE AT THE 2ND SET OF HOLES FROM THE FRONT.
3. INSTALL THE MOUNTING BRACKETS (ITEMS #5, #7, #9 & #10) USING THE 5/16-18 X 1" HEX BOLTS (ITEM #11), 5/16" FLAT WASHERS (ITEM #18) AND 5/16" LOCK WASHERS (ITEM #19) AS SHOWN IN FIG. 1. INTO THE MULTI THREAD U-NUTS. FINGER TIGHTEN ONLY AT THIS TIME.
4. INSTALL THE 5/16-18 X 1" HEX BOLTS (ITEM #11), 5/16" FLAT WASHERS (ITEM #18) AND BLACK PLATED 5/16" SERRATED FLANGE NUTS (ITEM #17) THROUGH THE HOLES IN THE LOWER PINCH WELD AND THE BRACKET AS SHOWN IN FIG. 1. FINGER TIGHTEN ONLY AT THIS TIME.
5. MAKE SURE THE TWO FRONT BRACKETS ARE UP TIGHT AGAINST THE VEHICLE SURFACE AT THE TOP AND TIGHTEN THE BOLT THAT GOES THROUGH THE PINCH WELD.
6. ON THE LEFT SIDE (DRIVERS SIDE), HOLES ARE PROVIDED FOR THE FRONT TWO BRACKETS. MOUNT THEM THE SAME AS THE RIGHT SIDE FRONT BRACKETS WERE MOUNTED.

O-MEGA STEP INSTALLATION:

NOTE: BEFORE ATTACHING THE O-MEGA STEPS TO THE BRACKETS, MOUNT THE STEP PADS (ITEM #4) TO THE STEP PLATES USING THE 1/2" TEK SCREWS (ITEM #13) PROVIDED. POSITION THE FRONT STEP PAD AT ABOUT 7-1/2" FROM THE FRONT. WHEN INSTALLING THE PADS ON THE STEPS, DRILL AND INSTALL THE TWO CENTER SCREWS FIRST. IF INSTALLING THE PADS WHEN THE TEMPERATURE IS AROUND 70° F., MAKE SURE THE SCREWS IN THE END SLOTTED HOLES ARE IN THE MIDDLE OF THE SLOT. WHEN TURNING IN THE SCREWS, TURN THEM IN SNUG THEN BACK OFF A ¼ TURN. PLASTIC WILL EXPAND WHEN IT IS HOT AND CONTRACT WHEN IT GETS COLD AND THE SLOT WILL ALLOW THIS TO HAPPEN WITHOUT RISING UP BETWEEN THE SCREWS. **(NOTE: MOUNT REAR PADS AT YOUR DISCRETION.)**

7. INSTALL FIVE SQUARE HEAD SCREWS, 5/16-18 X 1" (ITEM #12) IN THE FRONT TRACK AND FIVE SQUARE HEAD SCREWS, 5/16-18 X 1" (ITEM #12) IN THE REAR TRACK OF THE RIGHT SIDE STEP PLATE.
8. POSITION THE MEGA STEP ON THE MOUNTING BRACKETS SO THAT THE SQUARE HEAD SCREWS ARE LOCATED IN THE SLOTS OF THE MOUNTING BRACKETS AND THE STEP IS CENTERED, FRONT TO REAR, ON THE VEHICLE. INSTALL 5/16" SERRATED FLANGE NUTS (ITEM #16) ON THE SQUARE HEAD SCREWS. FINGER TIGHTEN ONLY AT THIS TIME.



9. ALIGN THE STEP PLATE WITH THE BOTTOM OF THE BODY SHEET METAL. THE BOTTOM EDGE OF THE MOUNTING BRACKET FLANGES SHOULD BE EVEN WITH THE BOTTOM EDGE OF THE PINCH WELD ON THE VEHICLE. TIGHTEN THE BOLTS FROM THE STEP PLATE TO THE FRAME TO 19 FOOT POUNDS OF TORQUE.
10. TIGHTEN THE BRACKET TO BODY MOUNTING BOLTS TO 19 FOOT POUNDS OF TORQUE.
11. INSTALL TWO SQUARE HEAD SCREWS, 5/16-18 X 1" (ITEM #12) IN THE FRONT TRACK AND TWO SQUARE HEAD SCREWS, 5/16-18 X 1" (ITEM #12) IN THE REAR TRACK OF THE LEFT SIDE STEP PLATE.
12. POSITION THE MEGA STEP ON THE MOUNTING BRACKETS SO THAT THE SQUARE HEAD SCREWS ARE LOCATED IN THE SLOTS OF THE MOUNTING BRACKETS AND THE STEP IS CENTERED, FRONT TO REAR, ON THE VEHICLE. INSTALL 5/16" SERRATED FLANGE NUTS (ITEM #16) ON THE SQUARE HEAD SCREWS. FINGER TIGHTEN ONLY AT THIS TIME.
13. ALIGN THE STEP PLATE WITH THE BOTTOM OF THE BODY SHEET METAL. THE BOTTOM EDGE OF THE MOUNTING BRACKET FLANGES SHOULD BE EVEN WITH THE BOTTOM EDGE OF THE PINCH WELD ON THE VEHICLE. TIGHTEN THE BOLTS FROM THE STEP PLATE TO THE FRAME TO 19 FOOT POUNDS OF TORQUE.
14. TIGHTEN THE BRACKET TO BODY MOUNTING BOLTS TO 19 FOOT POUNDS OF TORQUE.

GRIP STEP INSTALLATION:

7. BEFORE ATTACHING THE GRIP STEPS TO THE BRACKETS, SLIDE THE APPROPRIATE NUMBER OF SUPPORT BRACES (ITEM #22) INTO THE CHANNEL OF THE STEPS.
8. SLIDE THE END CAPS (ITEM #21) OVER THE FRONT AND REAR OF EACH STEP. USING THE SUPPLIED #8 X 1/2" SELF DRILLING TEK SCREWS (ITEM #13), SCREW THE END CAP TO THE STEPS.
9. SET THE STEPS ON THE MOUNTING BRACKETS, AND SLIDE EACH SUPPORT BRACE OVER THE TOP OF EACH MOUNTING BRACKET, ATTACH THE FLAT SPACER PLATE (ITEM #23) TO THE BOTTOM OF THE STEP BETWEEN, THE SUPPORT BRACE AND THE TOP OF THE MOUNTING BRACKET.
10. USING THE SUPPLIED 5/16"-18 X 1" CARRIAGE BOLTS (ITEM #24), 5/16" FLAT WASHERS (ITEM #25) AND 5/16"-18 SERRATED FLANGE NUTS (ITEM #16), ATTACH THE STEP ASSEMBLIES AND FLAT SPACER PLATES (ITEM #23) TO THE MOUNTING BRACKETS.
11. SLIDE THE STEP PLATES TO THE CORRECT POSITION. TIGHTEN THE 5/16" FLANGE NUTS (ITEM #16) ON THE CARRIAGE BOLTS (ITEM #24) TO 19 FOOT POUNDS OF TORQUE.
12. TIGHTEN THE BRACKET TO BODY MOUNTING BOLTS TO 19 FOOT POUNDS OF TORQUE.



SERVICE PARTS LIST

MODEL NO.: 570124/585100

MODEL NO.: 570124/586100

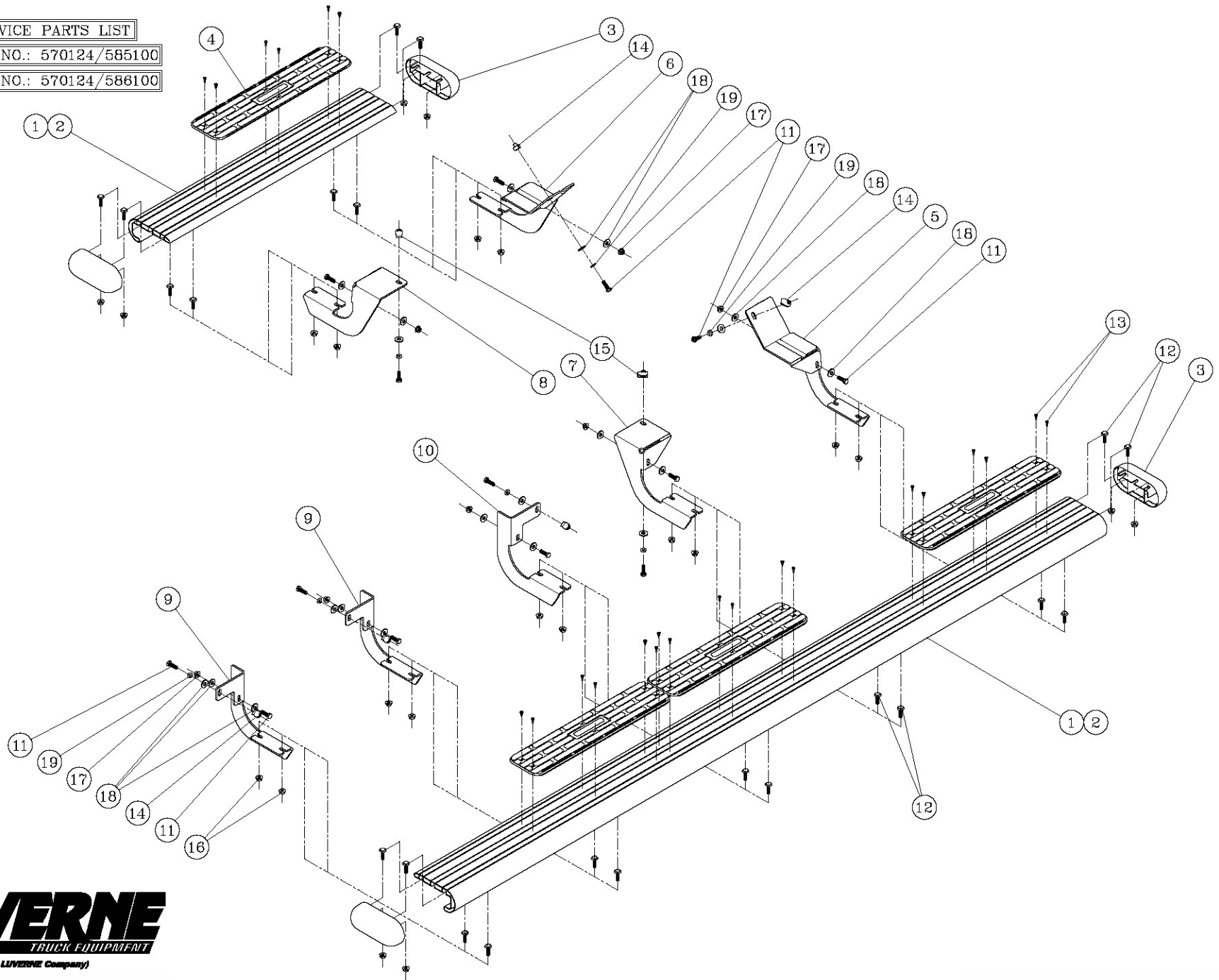

SERVICE PARTS LIST

MODEL NO.: 570124/415100

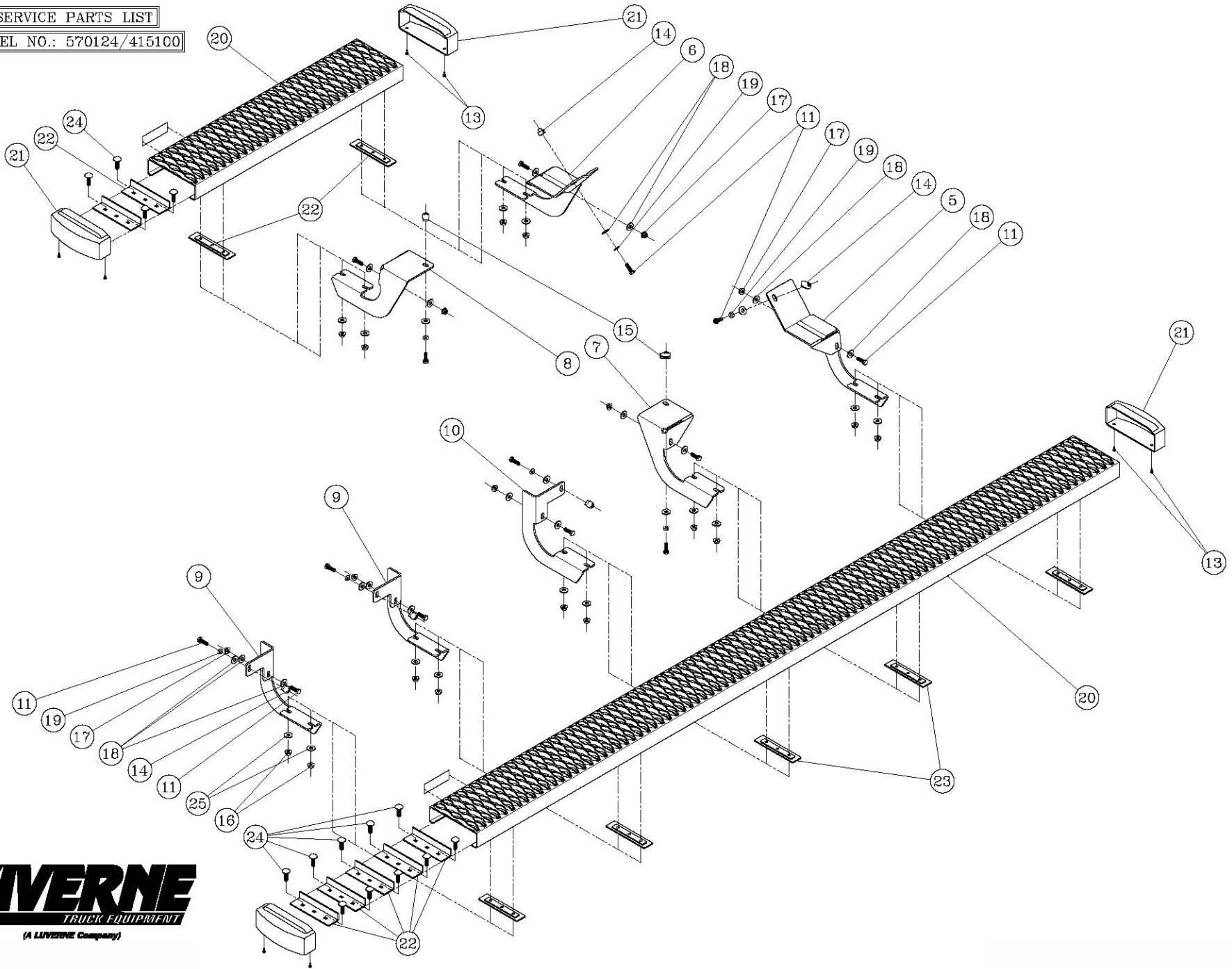

SERVICE PARTS LIST

ITEM	PART NO.	QTY	DESCRIPTION
1	585100	1	O-MEGA STEP BOARDS – 36” & 98”, SATIN
2	586100	1	O-MEGA STEP BOARDS – 36” & 98”, BLACK
3	107956	4	END CAP – O-MEGA STEP
4	107957	6	STEP PAD – 4-1`/2” x 20”
5	551789	1	MOUNTING BRACKET – FRONT, RH
6	551790	1	MOUNTING BRACKET - FRONT, LH
7	551791	1	MOUNTING BRACKET – CENTER, RH
8	551792	1	MOUNTING BRACKET – CENTER, LH
9	551793	2	MOUNTING BRACKET – REAR, RH
10	551794	1	MOUNTING BRACKET – REAR, LH
11	106997	14	SCREW – HHC, 5/16”-18 X 1”, BZP
12	106880	22	SCREW - SQUARE HD,5/16”-18 X 1”
13	107958	24	SCREW - PPH, TEK,#8-18 X 1/2”, SST
14	104264	5	U-NUT – MULTI THREAD, 5/16”-18
15	105541	2	U-NUT – MULTI THREAD, 5/16”-18, LONG
16	102680	22	NUT – SERRATED FLANGE, 5/16”-18, SST
17	106996	7	NUT – SERRATED FLANGE, 5/16”-18, BZP, SST
18	106998	21	FLAT WASHER - 5/16”, SST, BZP
19	102668	7	LOCK WASHER - 5/16”, SST
20	415100	1	GRIP STEPS - 36” & 98”
21	551394	4	END CAP – GRIP STEP
22	551296	7	SUPPORT BRACE - UPPER
23	551298	7	SPACER PLATE - LOWER
24	108683	14	BOLT - CARRIAGE - 5/16”-18 X 1”, SST
25	101369	14	FLAT WASHER – 5/16”, SST



Get in and out of your truck or SUV easier with running boards available on our website.