

INSTALLATION INSTRUCTIONS AND PARTS LIST

MODEL 415100, 36" & 98" GRIP STEPS (BOARDS ONLY)

1. READ INSTRUCTIONS COMPLETELY AND CHECK TO MAKE SURE THAT ALL REQUIRED PARTS (LISTED ON THE SERVICE PARTS LIST) ARE ON HAND BEFORE STARTING THE INSTALLATION.
2. FOLLOW THE INSTRUCTIONS INCLUDED WITH THE SPECIFIC BRACKET PACKAGE THAT YOU ARE USING TO MOUNT THE BRACKETS TO YOUR VEHICLE.
3. STEP ASSEMBLY:
 - 3.1 BEFORE ATTACHING THE GRIP STEPS TO THE BRACKETS, SLIDE THE APPROPRIATE NUMBERS OF SUPPORT BRACES (ITEM #2) INTO THE CHANNEL OF THE STEP (ITEM #1).
 - 3.2 SLIDE THE END CAP (ITEM #3) OVER THE FRONT AND REAR OF EACH STEP. USING THE SUPPLIED #8 X 1/2" SELF-DRILLING TEK SCREW (ITEM #8); SCREW THE END CAP TO THE BOTTOM OF THE STEP.
4. ATTACHING THE STEP TO THE MOUNTING BRACKETS:
 - 4.1 SET THE STEP ON THE MOUNTING BRACKETS, AND SLIDE EACH SUPPORT BRACE OVER THE TOP OF EACH MOUNTING BRACKET. ATTACH THE FLAT SPACER PLATE (ITEM #4) TO THE BOTTOM OF THE STEP, BETWEEN THE SUPPORT BRACE, AND THE TOP OF THE MOUNTING BRACKET.
 - 4.2 USING THE SUPPLIED 5/16-18 x 1" CARRIAGE BOLT, WASHER, AND FLANGE NUTS, (ITEM # 5, 6, 7), ATTACH THE STEP ASSEMBLY, FLAT SPACER PLATE AND MOUNTING BRACKET.
 - 4.3 SET THE STEP PLATE IN THE CORRECT POSITION AND TIGHTEN ALL FASTENERS. TORQUE ALL 5/16" FASTENERS TO 19 LB FT.

SERVICE PARTS LIST

ITEM	PART NO.	QTY	DESCRIPTION
1	551699	1	EXTRUSION-AL,36.00, GRIP STEP,BLK,415100
1	551888	1	EXTRUSION-AL,98.00,GRIP STEP,BLK,415100
2	551296	7	SUPPORT BRACE, UPPER, GALV
3	551394	4	CAP-END,GRIP STEP, BLACK, PLASTIC
4	551298	7	SPACER PLATE, LOWER, BLACK
5	108683	14	BOLT-CRG,5/16-18 X 1.0", SST
6	101369	14	WASHER-FLAT,5/16,SST
7	102680	14	NUT-SERR FLG,HX,SST,WX,5/16-18
8	107958	8	SCR-TEK #8-18 X 1/2",SST,BLK

LUPERNE
TRUCK EQUIPMENT

(A LUPERNE Company)

SERVICE PARTS LIST

MODEL NO. - 415100

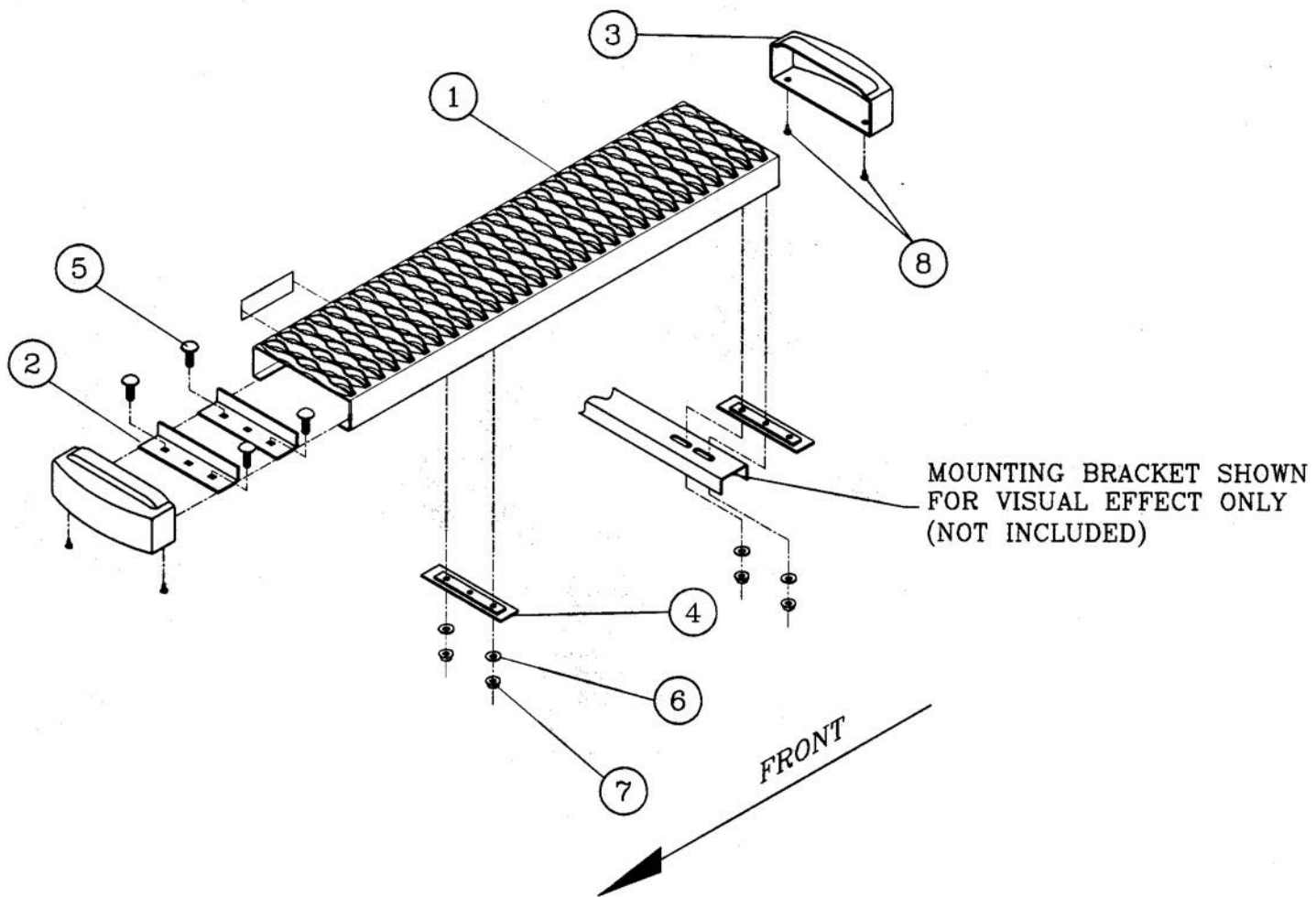

(A LIVERNE Company)

SERVICE PARTS LIST

MODEL NO. - 415100

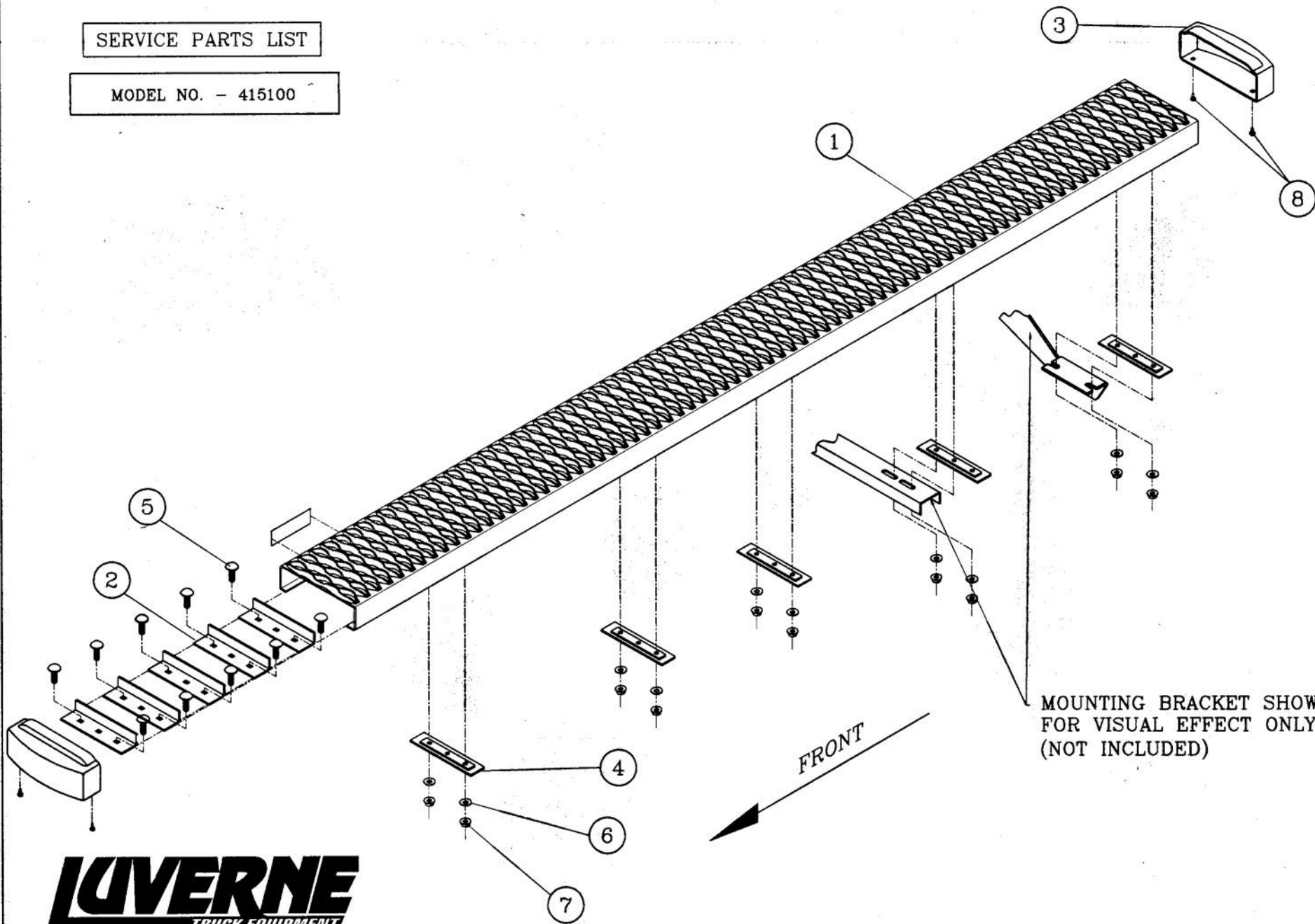

MOUNTING BRACKET SHOWN FOR VISUAL EFFECT ONLY (NOT INCLUDED)

FRONT

LIVERNE
TRUCK EQUIPMENT

(A LIVERNE Company)

INSTALLATION INSTRUCTIONS AND PARTS LIST

MODEL

401164 GRIP STEP BRACKETS SHORT/LONG

2011 NISSAN NV VANS

READ INSTRUCTIONS COMPLETELY AND CHECK TO MAKE SURE THAT ALL REQUIRED PARTS (LISTED ON SERVICE PARTS LIST) ARE ON HAND BEFORE STARTING THE INSTALLATION.

DRIVER SIDE INSTALLATION

1. DRILL (1) 3/8" DIAMETER HOLE THROUGH THE MIDDLE OF THE PINCH WELD FOR THE BOTTOM MOUNTING HOLE. SEE **FIG.1** TO MARK THE LOCATION FOR THE FRONT BRACKET WHICH IS MEASURED FROM THE FRONT WHEEL WELL OPENING.
2. ASSEMBLE THE SUPPORT BRACKET ASSEMBLY AS SHOWN IN **FIG.2** AND INSERT INTO THE NEAREST FRAME OPENING TO THE RECOMMENDED REAR BRACKET LOCATION (SEE **FIG.1**).
3. USING A 3/8"-16 X 0.75" BOLT, TWO 3/8" FLAT WASHERS, AND A 3/8"-16 FLANGE NUT (ITEMS #8, 9, 10) ATTACH THE REAR BRACKET TO THE SUPPORT BRACKET ASSEMBLY; DO NOT TIGHTEN AT THIS TIME. HOLD THE BRACKET UP TO THE VEHICLE AS SHOWN AND MARK THE BOTTOM HOLE LOCATION ON THE PINCH WELD. DRILL (1) 3/8" DIAMETER HOLE THROUGH THE MIDDLE OF THE PINCH WELD AT THIS LOCATION.
4. HOLD TWO OF THE BRACKETS (ITEM #1) UP TO THE VEHICLE AS SHOWN SECURING THEM WITH A 5/16-18X1.0 BOLT, FLANGE NUT, AND 2 WASHERS (ITEMS #2, 3, 4). TIGHTEN THESE FASTENERS DOWN ENSURING THAT THEY ARE LEVEL WITH THE VEHICLE.
5. WITH THE (2) BRACKETS IN PLACE AND WITH THE UPPER SURFACE IN CONTACT WITH THE VEHICLE, USE THE TOP (2) HOLES IN THE BRACKET AS A GUIDE AND DRILL (2) 5/32" HOLES THROUGH THE INNER ROCKER PANEL FOR EACH BRACKET. INSTALL THE 1/4" X 3/4" SELF TAPPING SCREWS (ITEM #5) **USE CARE NOT TO OVER TIGHTEN.**
6. TIGHTEN ALL SUPPORT BRACKET FASTENERS ON THE REAR BRACKET.

PASSENGER SIDE INSTALLATION

7. DRILL (2) 3/8" DIAMETER HOLES THROUGH THE MIDDLE OF THE PINCH WELD FOR THE BOTTOM MOUNTING HOLE. SEE **FIG. 3** TO MARK THE LOCATIONS FOR THE **FIRST** AND **THIRD** BRACKET, WHICH ARE MEASURED FROM THE FRONT WHEEL WELL OPENING.
8. HOLD THESE BRACKETS (ITEM #1) UP TO THE VEHICLE AS SHOWN SECURING THEM WITH A 5/16-18X1.0 BOLT, FLANGE NUT, AND (2) WASHERS (ITEMS #2,3,4). SNUG THESE FASTENERS DOWN.
9. ASSEMBLE THE SUPPORT BRACKET ASSEMBLIES AND INSERT INTO THE NEAREST FRAME OPENING TO THE RECOMMENDED LOCATIONS FOR THE **SECOND** AND **FOURTH** BRACKETS.
10. USING A 3/8"-16 X 0.75" BOLT, TWO 3/8" FLAT WASHERS, AND A 3/8"-16 FLANGE NUT (ITEMS #8, 9, 10) ATTACH THE SECOND AND FOURTH BRACKET TO THE SUPPORT BRACKET ASSEMBLY; DO NOT TIGHTEN AT THIS TIME. HOLD THE BRACKETS UP TO THE VEHICLE AS SHOWN AND MARK THE BOTTOM HOLE LOCATION ON THE PINCH WELD. DRILL (2) 3/8" DIAMETER HOLE THROUGH THE MIDDLE OF THE PINCH WELD AT THESE LOCATIONS.
11. WITH THE (4) BRACKETS IN PLACE USE THE UPPER (2) HOLES IN THE BRACKET AS A GUIDE AND DRILL (2) 5/32" HOLES THROUGH THE INNER ROCKER PANEL FOR EACH BRACKET. INSTALL THE 1/4" X 3/4" SELF TAPPING SCREWS (ITEM #5) **USE CARE NOT TO OVER TIGHTEN.**
12. TIGHTEN ALL SUPPORT BRACKET FASTENERS



13. ATTACHING THE STEP ASSEMBLY:

PLEASE REVIEW THE INSTALLATION INSTRUCTIONS THAT ARE INCLUDED IN YOUR STEP ASSEMBLY FOR SPECIFIC DETAILS.

SERVICE PARTS LIST

ITEM	PART NO.	QTY	DESCRIPTION
1	552131	6	BRKT- MTG, NISSAN NV, GRIP STEPS
2	106997	6	SCREW- HEX HEAD CAP, 5/16_18 UNC X 1.00".SST,BZP
3	106998	12	WSHR-FL, 5/16, SST,BZP
4	106996	6	NUT-SERRATED FLANGE, 5/16-18,SST,BZP
5	100004	12	SCREW- HEX HEAD SELF TAPPING,1/4" X 3/4", ZP
6	552771	3	T-BOLT WELDMENT
7	551085	3	PLATE-SPACER, BZP
8	106995	12	NUT-SERRATED FLANGE, 3/8"-16, SST, BZP
9	106962	9	WASHER-FLAT, 3/8", BZP
10	107866	3	SCREW- HEX HEAD, 3/8"-16 X 0.75", BZP
11	108442	3	WASHER-NYLON, .360" X 1.5" X .032", BLACK
12	552810	1	SUPPORT BRACKET – LH
13	552811	1	SUPPORT BRACKET – RH



SERVICE PARTS LIST

BRACKET NO. - 401164

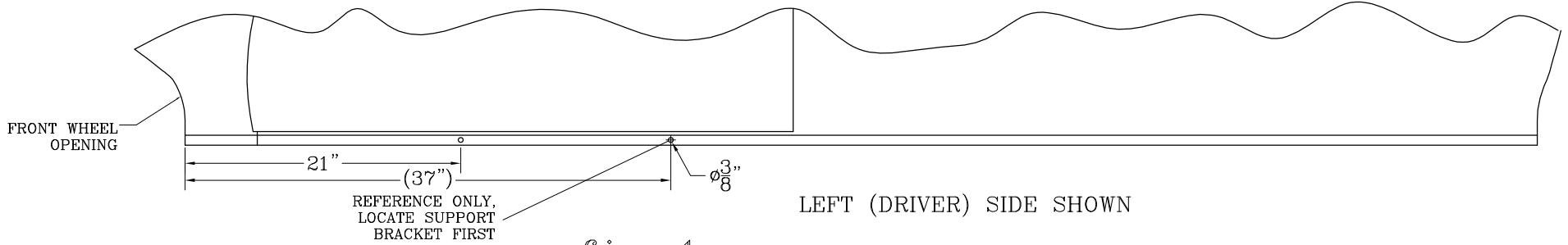
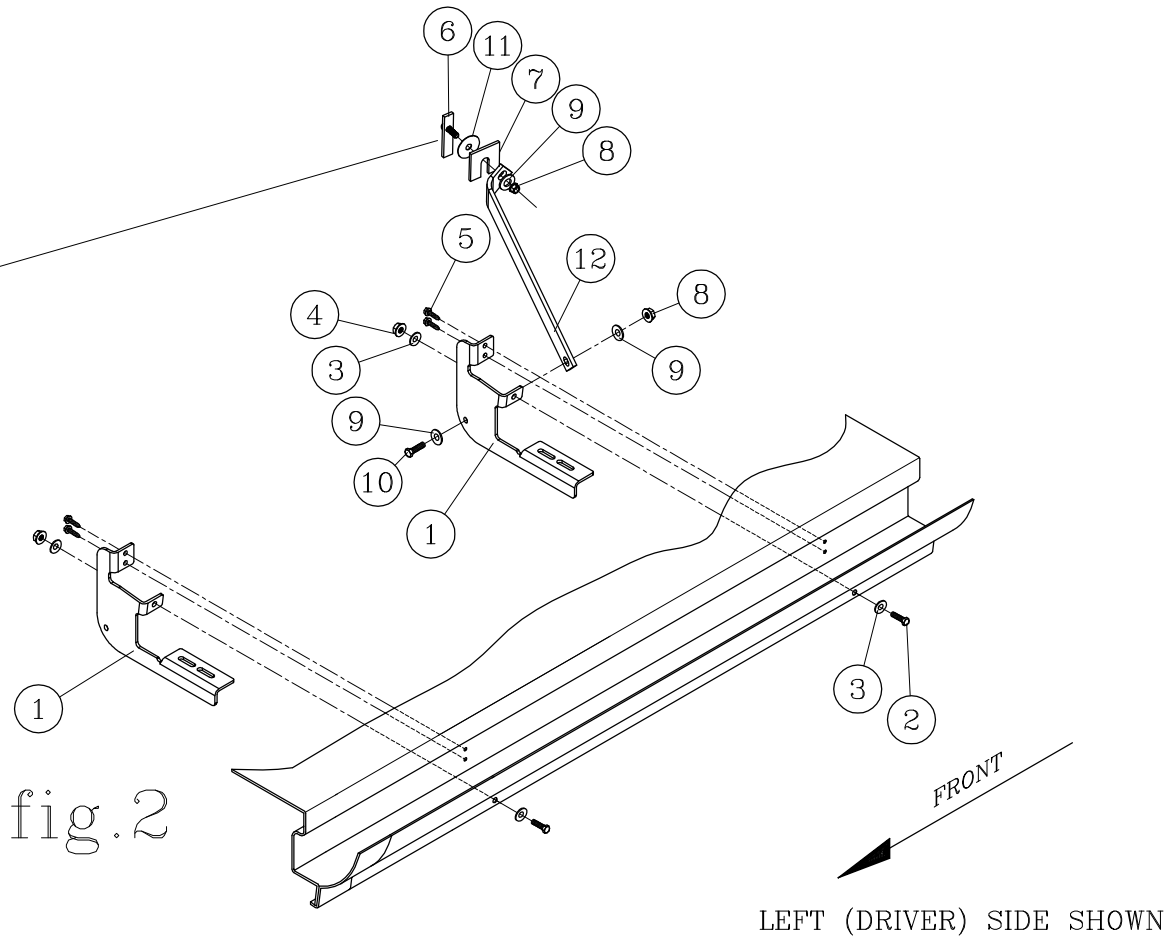
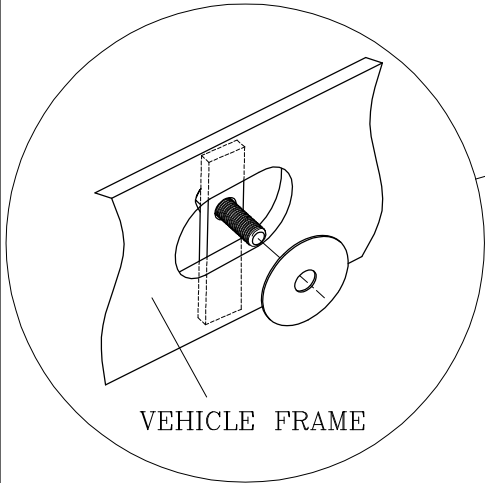
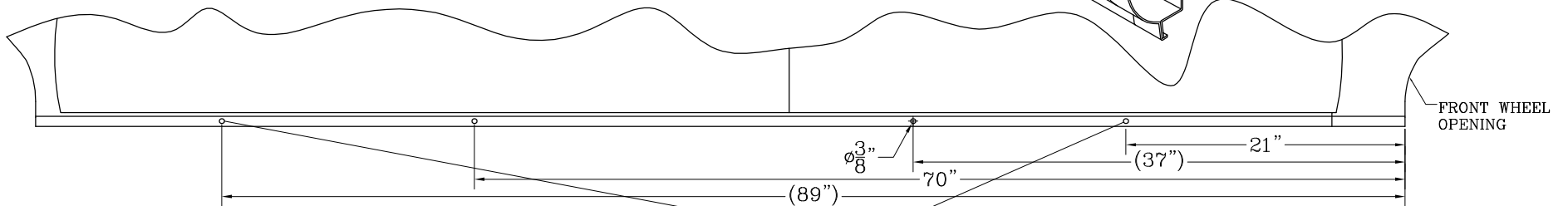
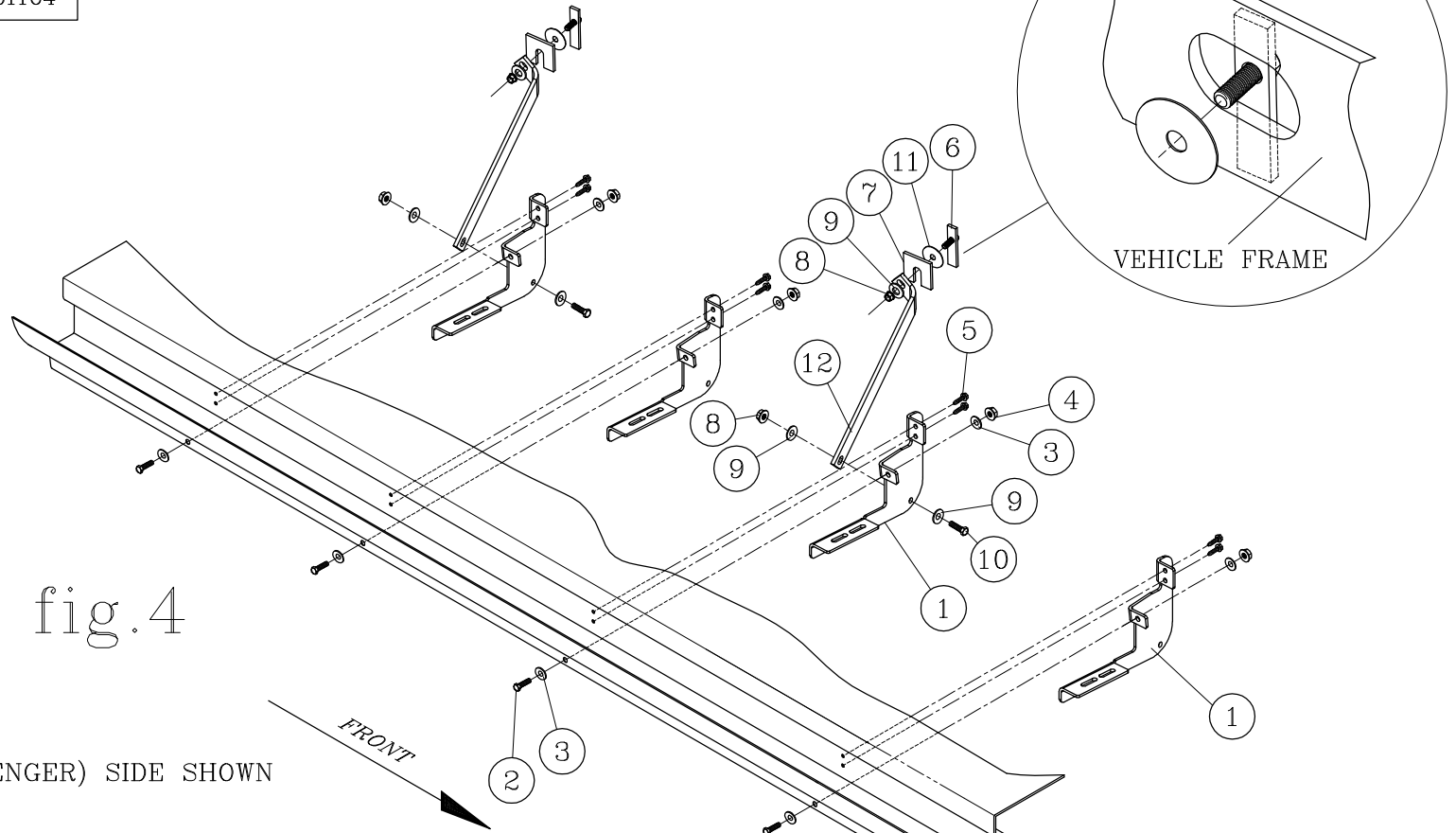

fig. 1

SERVICE PARTS LIST

BRACKET NO. - 401164



REFERENCE ONLY,
LOCATE SUPPORT
BRACKET FIRST



Choose reliable running boards offered on our website.