

INSTALLATION INSTRUCTIONS AND PARTS LIST

MODEL 415114, GRIP STEPS (BOARDS ONLY)

UNIVERSAL APPLICATIONS

1. Read instructions completely and check to make sure that all required parts (listed on the service parts list) are on hand before starting the installation.
2. Follow the instructions included with the specific bracket package to mount the brackets to your vehicle.
3. Step assembly:
 - 3.1 This Board can be modified from its original length to fit many applications. Simply determine how long you will need the board, and cut to that length using a saber saw, chop saw, or hack saw. Use flat black paint to touch up the ends that were cut.
 - 3.2 Before attaching the grip steps to the brackets, slide the appropriate number of support braces (item #2) into the channel of the step (item #1).
 - 3.3 Slide the end cap (item #3) over the front and rear of each step. Using the supplied #8 x 1/2" self drilling tek screw (item #8), screw the end cap to the bottom of the step.
4. Attaching the step to the mounting bracket:
 - 4.1 Set the step on the mounting brackets, and slide each support brace over the top of each mounting bracket. Attach the flat spacer plate (item #4) to the bottom of the step, between the support brace, and the top of the mounting bracket.
 - 4.2 Using the supplied 5/16-18 x 1" carriage bolt, washer, and flange nuts, (item #5, 6, 7), attach the step assembly, flat spacer plate and mounting bracket. **(NOTE: Some of the flange nuts are supplied in the specific bracket package, not the step package.)**
 - 4.3 Set the step plate in the correct position and tighten all fasteners.
Torque all fasteners to 19 LB FT.

SERVICE PARTS LIST

ITEM	PART NO.	QTY	DESCRIPTION
1	551888	2	EXTRUSION-AL,97.87,GRIP STEP,BLK,415098
1	551889	2	EXTRUSION-AL,101.25,GRIP STEP,BLK,415102
1	551388	2	EXTRUSION-AL,113.62,GRIP STEP,BLK,415114
2	551296	10	SUPPORT BRACE, UPPER, GALV.
3	551394	4	CAP-END,GRIP STEP, BLACK, PLASTIC
4	551298	14	SPACER PLATE, LOWER, BLACK
5	108683	20	BOLT-CRG,5/16-18 X 1.0", SST
6	101369	20	WASHER-FLAT,5/16,SST
7	102680	20	NUT-SERR FLG,HX,SST,WX,5/16-18
8	107958	8	SCR-TEK #8-18 X 1/2",SST,BLK



SERVICE PARTS LIST

MODEL NO. - 415098
415102
415114

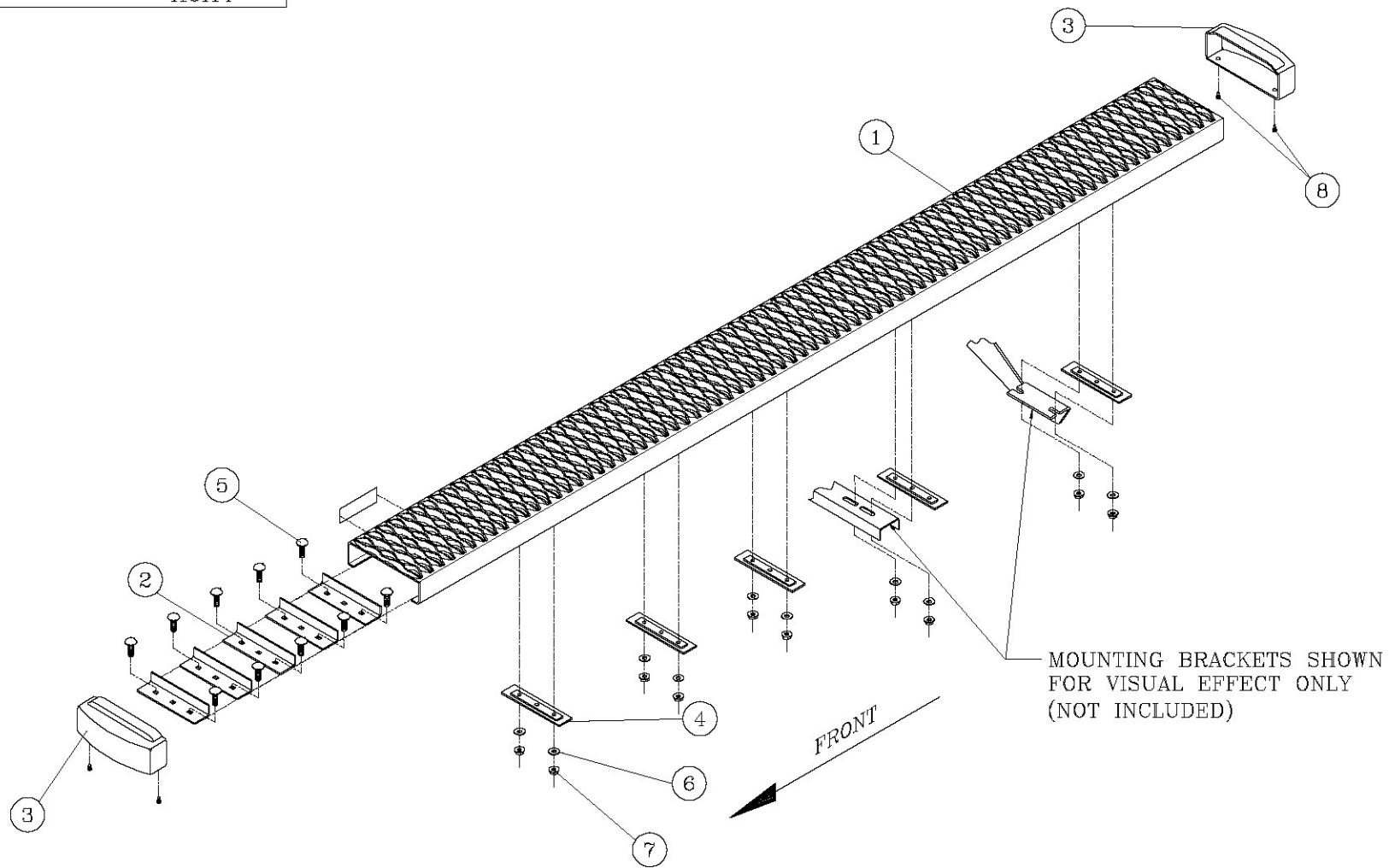

INSTALLATION INSTRUCTIONS AND PARTS LIST

FOR MOUNTING 400745 GRIP STEPS 2007-NEWER SPRINTER VANS

READ INSTRUCTIONS COMPLETELY AND CHECK TO MAKE SURE THAT ALL REQUIRED PARTS (LISTED ON SERVICE PARTS LIST) ARE ON HAND BEFORE STARTING THE INSTALLATION.

DRIVERS SIDE INSTALLATION

1. PREASSEMBLE BRACKETS (ITEM 1 & 2) WITH SPACER BRACKETS (ITEM 8), USING THE 5/16-18 BOLTS WITH THE 5/16" WASHERS AND THE FLANGE NUTS (ITEMS 2, 10 & 11). FINGER TIGHTEN THEM ONLY AT THIS TIME.
2. ATTACHING THE FRONT BRACKET:
 - 2.1 ON THE BACK SIDE OF THE ROCKER PANEL, MEASURE ABOUT 9-1/2" BACK FROM THE FRONT OF THE MUD FLAP. IN THIS LOCATION THERE SHOULD BE A BODY PLUG
 - 2.2 IF THE TRUCK DOES NOT HAVE REAR A/C SCRAPE THE UNDER COATING OFF AROUND THE BODY PLUG AND REMOVE THE PLUG. THEN DRILL A 7/16" HOLE 1/2" TO THE FRONT OF THE BODY PLUG HOLE AND INSERT THE 5/16-18 U-NUT. (ITEM #4) PLACE BRACKET IN PLACE USING THE TOP SLOT AND FASTEN USING THE 5/16-18 BOLT AND WASHER. (ITEM # 2 & 10)
 - 2.3 IF THE TRUCK DOES HAVE REAR A/C YOU WILL NOT NEED TO REMOVE THE BODY PLUG INSTEAD PLACE THE PREASSEMBLED BRACKET INTO PLACE AND MARK THE HOLE LOCATION USING THE CENTER ROUND HOLE IN THE BRACKET AS A GUIDE. (MAKE SURE THAT THE BRACKET IS LEVEL WITH THE TRUCK) REMOVE THE BRACKET AND CENTER PUNCH THE MARKED HOLE AND DRILL WITH A 7/32 DRILL. PLACE BRACKET BACK IN PLACE AND INSTALL THE 1/4" SELF-TAPPING SCREW (ITEM #5). SEE FIG 1.
 - 2.4 ONCE THE BRACKET IS IN PLACE THE LOWER MOUNT IS READY TO BE DRILLED. USING A 11/32 DRILL BIT THE TWO HOLES IN THE LOWER BRACKET MOUNT CAN BE USED AS A DRILLING GUIDE.
 - 2.5 ONCE THE DRILLING IS DONE FASTEN THE BRACKET TO THE PINCH WELD USING THE SUPPLIED BLACK 5/16-18 BOLT AND 5/16 WASHER THROUGH THE DRILLED HOLES. ON THE BACK SIDE OF THE PINCH WELD PLACE THE RETAINER PLATE (ITEM #9) OVER THE BOLTS AND FASTEN THEM WITH THE SUPPLIED FLANGE NUT (ITEM #11), AND TIGHTEN DOWN ALL THE FASTENERS.
3. ATTACHING THE REAR BRACKET:
 - 3.1 ON THE BACK SIDE OF THE ROCKER PANEL, MEASURE ABOUT 27 1/2" BACK FROM THE FRONT OF THE MUD FLAP. THIS IS ABOUT WHERE THE SECOND BRACKET WILL BE INSTALLED.
 - 3.2 MEASURE THE HEIGHT OF THE FIRST BRACKET FROM THE TOP OF THE BRACKET TO THE BOTTOM OF THE FLOOR BOARD; THIS WILL HELP WITH MOUNTING THE BOARD LEVEL.
 - 3.3 USING THE BRACKET AS A GUIDE MARK THE HOLE USING THE TOP SLOT IN THE BRACKET. CENTER PUNCH AND DRILL USING A 7/32 DRILL BIT.
 - 3.4 POSITION THE BRACKET OVER THE HOLE JUST DRILLED AND FASTEN USING THE SUPPLIED SELF-TAPPING SCREW (ITEM #5). HAND TIGHTEN ONLY AT THIS TIME.
 - 3.5 WITH THE BRACKET IN PLACE REPEAT STEPS 2.4 & 2.5.
4. ATTACHING THE BACK TWO BRACKETS:
 - 4.1 USING THE TWO PREASSEMBLED BRACKETS (ITEM #2) SPACE THEM EVENLY FOR BEST FITMENT ON THE BACK HALF OF THE BOARD, AND REPEAT STEP 3 FOR DRILLING APPLICATIONS, WHILE ADDING IN THE SPACER PLATE (ITEM #12) BETWEEN THE TOP OF THE MAIN BRACKET AND THE ROCKER PANEL. (SEE FIG. 1)



PASSANGER SIDE INSTALLATION

1. PREASSEMBLE BRACKETS (ITEMS #1 & 3) WITH SPACER BRACKETS (ITEM 8), USING THE 5/16-18 BOLTS WITH THE 5/16 WASHERS AND THE FLANGE NUTS (ITEMS 2, 10 & 11). FINGER TIGHTEN THEM ONLY AT THIS TIME.
2. ATTACHING THE FRONT TWO BRACKETS WILL BE THE SAME AS THE DRIVERS SIDE, STEPS 2 THRU 3.
3. ATTACHING REAR BRACKETS:
 - 3.1 ON THE BACK SIDE OF THE ROCKER PANEL, MEASURE 48-1/2 “ BACK FROM THE FRONT OF THE MUD FLAP. IN THIS LOCATION THERE SHOULD BE A BODY PLUG. SCRAP AWAY THE UNDER COATING AND REMOVE THE BODY PLUG. MEASURE BACK 1/2” FROM THE OPENING AND DRILL A 7/16” HOLE, AND INSERT THE 5/16-18 U-NUT (ITEM #4). PLACE THE PREASSEMBLED BRACKETS (ITEM #3 & 8) IN PLACE, USING THE TOP SLOT IN THE MAIN BRACKET FASTEN WITH THE SUPPLIED FASTENERS (ITEM #2 & 10) TO THE U-NUT.
 - 3.2 USING THE LOWER BRACKET AS A GUIDE DRILL TWO 11/32” HOLES INTO THE PINCH WELD. FASTEN THEM USING THE SAME STEPS IN STEP 2.5.
 - 3.3 USING THE SAME STEPS AS ABOVE MEASURE BACK 68-1/2” AND 88-1/2” THERE WILL BE BODY PLUGS IN THESE LOCATIONS.
 - 3.4 THE BODY PLUG LOCATIONS USED WILL BE THE SECOND, FORTH, AND SIXTH LOCATIONS.
4. ATTACHEING THE STEP ASSEMBLY:

PLEASE REVIEW THE INSTALLATION INSRTRUCTIONS THAT ARE INCLUDED IN YOU STEP ASSEMBLY FOR SPECIFIC DETAILS.

SERVICE PARTS LIST

ITEM	PART NO.	QTY	DESCRIPTION
1	551941	6	BRACKET-MTG, 12 GA, LH/RH
2	551940	3	BRACKET-MTG, CENTER,400744
3	100034	18	WASHER-FL, 5/16, ZP
4	105541	5	NUT-U, MULTI THD, LG, 5/16-18, BLK
5	105537	5	SCR-HWH, TF, AB, SST, 5/16 X 1.00
6	106997	18	SCR-HHCAP, 5/16-18 X 1.00, SST, BZP
7	106998	18	WASHER-FL, 5/16, BZP
8	552288	9	SPACER BRACKET, 7 GA, LH/RH
9	552289	9	PLATE-RETAINER, GALV, 7 GA
10	100647	14	SCR-HEX HD, 5/16-18 X 1.00 STL, ZP
11	100178	27	NUT-HEX FLG, 5/16-18
12	552018	2	SPACER PLATE, ZP, 570745



(A LIVERNE Company)

SERVICE PARTS LIST

BRACKET NO. - 400745

Fig 1.

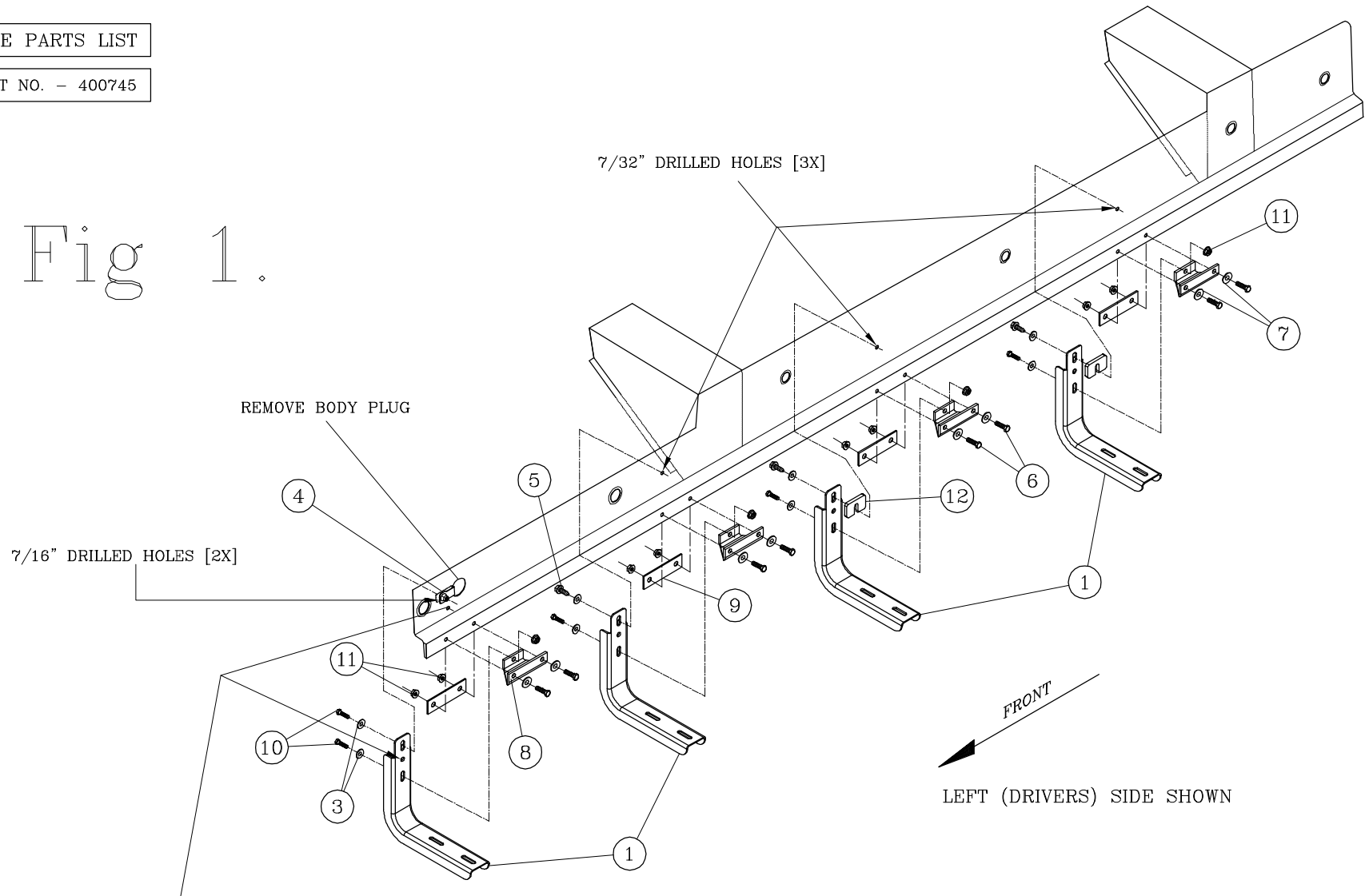

(REAR A/C ONLY)
WITH REAR A/C DRILL A 7/32" HOLE
USE SELF TAPPING SCREW (ITEM #11)
AND USE MIDDLE 3/8" HOLE IN BRACKET

FRONT
LEFT (DRIVERS) SIDE SHOWN

SERVICE PARTS LIST

BRACKET NO. - 400745

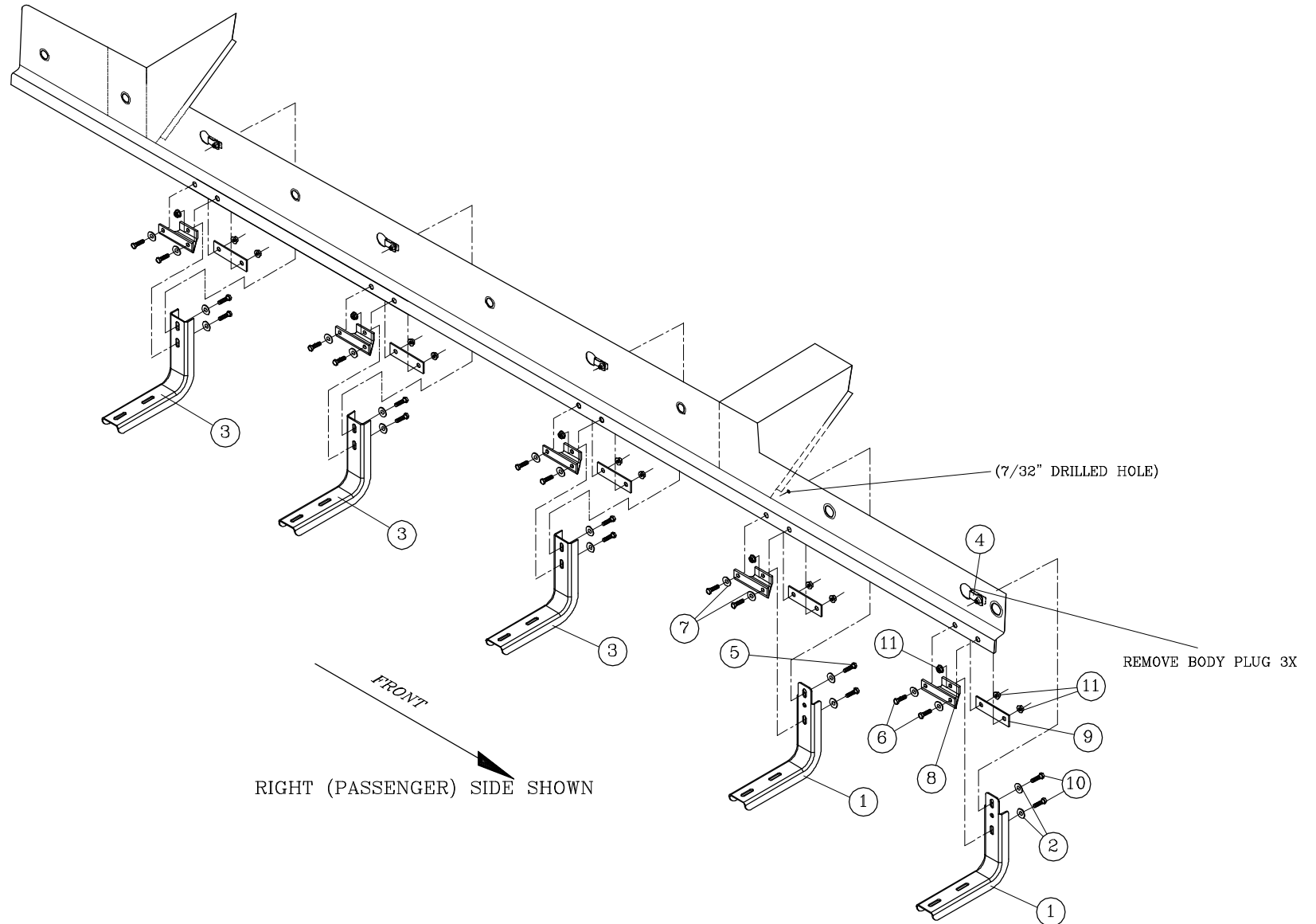

Get in and out of your truck or SUV easier with running boards available on our website.