

INSTALLATION INSTRUCTIONS AND PARTS LIST

MODEL 415078, 415088, GRIP STEPS (BOARDS ONLY)

UNIVERSAL APPLICATIONS

1. Read instructions completely and check to make sure that all required parts (listed on the service parts list) are on hand before starting the installation.
2. Follow the instructions included with the specific bracket package that you are using to mount the brackets to your vehicle.
3. Step assembly:
 - 3.1 Before attaching the grip steps to the brackets, slide the appropriate number of support braces (item #2) into the channel of the step (item #1).
 - 3.2 Slide the end cap (item #3) over the front and rear of each step. Using the supplied #8 x 1/2" self drilling tek screw (item #8), screw the end cap to the bottom of the step.
4. Attaching the step to the mounting bracket:
 - 4.1 Set the step on the mounting brackets, and slide each support brace over the top of each mounting bracket. Attach the flat spacer plate (item #4) to the bottom of the step, between the support brace, and the top of the mounting bracket.
 - 4.2 Using the supplied 5/16-18 x 1" carriage bolt, washer, and flange nuts, (item #5, 6, 7), attach the step assembly, flat spacer plate and mounting bracket. **(NOTE: Some of the flange nuts are supplied in the specific bracket package, not the step package.)**
 - 4.3 Set the step plate in the correct position and tighten all fasteners.
Torque all 5/16" fasteners to 19 LB FT.

SERVICE PARTS LIST

ITEM	PART NO.	QTY	DESCRIPTION
1	551384	2	EXTRUSION-AL,77.62, GRIP STEP,BLK,415078
1	551385	2	EXTRUSION-AL,87.75,GRIP STEP,BLK,415088
2	551296	8	SUPPORT BRACE, UPPER, GALV
3	551394	4	CAP-END,GRIP STEP, BLACK, PLASTIC
4	551298	8	SPACER PLATE, LOWER, BLACK
5	108683	16	BOLT-CRG,5/16-18 X 1.0", SST
6	101369	16	WASHER-FLAT,5/16,SST
7	102680	16	NUT-SERR FLG,HX,SST,WX,5/16-18
8	107958	8	SCR-TEK #8-18 X 1/2",SST,BLK

LIVERNE
TRUCK EQUIPMENT

(A LIVERNE Company)

SERVICE PARTS LIST

MODEL NO. - 415078
- 415088

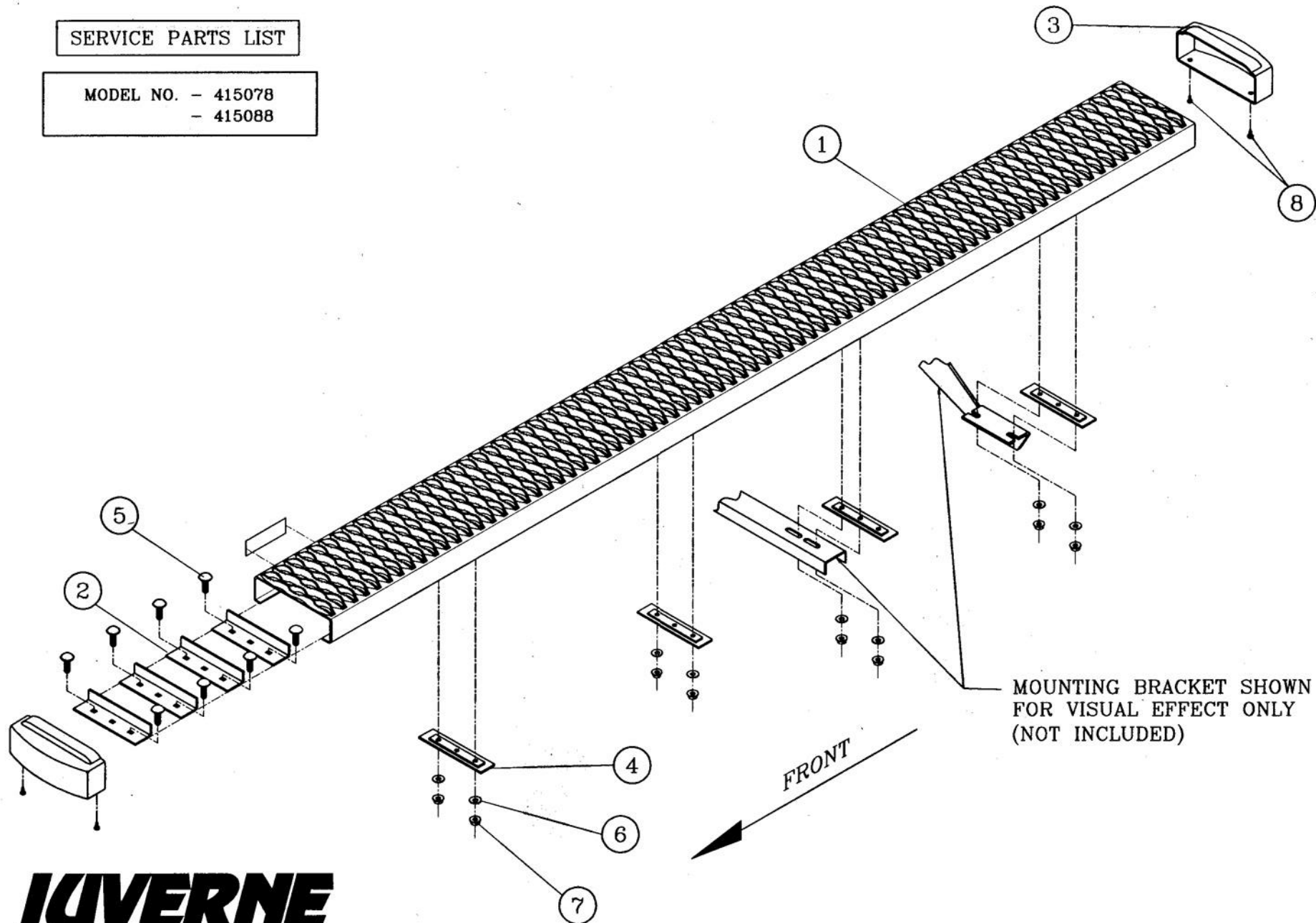

LIVERNE
TRUCK EQUIPMENT

(A LIVERNE Company)

INSTALLATION INSTRUCTIONS AND PARTS LIST

APPLICATION:

MODEL 400929 WHEEL TO WHEEL STEP BRACKETS:

2009 FORD F-150 REGULAR / SUPER CAB / SUPERCREW CAB PICKUPS

1. READ INSTRUCTIONS COMPLETELY AND CHECK TO MAKE SURE THAT ALL REQUIRED PARTS (LISTED ON THE SERVICE PARTS LIST) ARE ON HAND BEFORE STARTING THE INSTALLATION.
2. INSTALL 5/16" MULTI THREAD U-NUTS (ITEM #6) IN THE TOP REAR HOLE OF THE SECOND PATTERN FROM THE FRONT AND IN THE TOP FRONT HOLE OF THE THIRD PATTERN FROM THE FRONT AS SHOWN. INSTALL THESE U-NUTS SO THAT THE THREADS ARE TO THE INSIDE OF THE ROCKER PANEL. (THIS IS DONE BY INSERTING THE THREADED HALF OF THE U-NUT THRU THE LARGE ACCESS HOLES AND SLIDING THE U-NUT TOWARDS THE ROUND HOLE UNTIL IT SEATS IN THE ROUND HOLE).
3. **FRONT AND REAR BRACKET:** [SEE FIG 1] THESE BRACKETS WILL NEED TO BE APPROXIMATELY 6" FROM THE BACK OF THE CAB AND 6" FROM THE FRONT OF THE CAB AND WILL REQUIRE SOME DRILLING.
 - 3.1. CLAMP THE BRACKETS INTO POSITION. DRILL A (11/32") HOLE IN THE PINCH WELD AREA TO LINE UP WITH THE BOTTOM HOLE IN THE BRACKET.
 - 3.2. ATTACH THE BOTTOM OF THE BRACKET TO THE PINCH WELD WITH A 5/16" X 1.00" BLACK PLATED HEX HEAD CAP SCREW (ITEM #2), 5/16" BLACK PLATED FLAT WASHER (ITEM #3) AND 5/16" SERRATED FLANGE NUT (ITEM #5). LEVEL THE BRACKETS AND TIGHTEN THE BOLTS.
 - 3.3. DRILL A (7/32") HOLE INTO THE TOP OF THE ROCKER PANEL. INSTALL A SELF TAPPING SCREW (ITEM #10) INTO THE SMALL HOLE AND TIGHTEN, BE CAREFUL NOT TO OVER TIGHTEN.

SUPER CAB

4. ATTACH THE CENTER TWO MOUNTING BRACKETS (ITEM #1) TO THE VEHICLE.
 - 4.1. POSITION THE (2) BRACKETS ON THE VEHICLE SO THAT THE TOP HOLE LINES UP WITH THE MULTI THREAD U-NUT AND THE HOLE IN THE OFFSET LINES UP WITH THE HOLE IN THE PINCH WELD. ATTACH THE TOP OF THE BRACKET WITH A 5/16" X 1.00" ZINC PLATED HEX HEAD CAP SCREW (ITEM #8) AND 5/16" ZINC PLATED FLAT WASHER (ITEM #9). ATTACH THE BOTTOM OF THE BRACKET TO THE PINCH WELD WITH A 5/16" X 1.00" BLACK PLATED HEX HEAD CAP SCREW (ITEM #2), 5/16" BLACK PLATED FLAT WASHER (ITEM #3) AND 5/16" SERRATED FLANGE NUT (ITEM #5). LEVEL THE BRACKETS AND TIGHTEN THE FASTENERS.

SUPERCREW ONLY

5. ATTACH THE SECOND FROM THE FRONT MOUNTING BRACKET (ITEM #1) TO THE VEHICLE.
 - 5.1. ATTACH ANGLE BRACKET (ITEM #7) TO MOUNTING BRACKET (ITEM #1) WITH A 5/16" X 1.00" ZINC PLATED HEX HEAD CAP SCREW (ITEM #8) AND 5/16" ZINC PLATED FLAT WASHER (ITEM #9). AND A 5/16" SERRATED FLANGE NUT (ITEM #5) TOGETHER WITH THE ANGLE TOWARDS THE MULTI THREAD U-NUT IN THE HOLE THAT IS OFFSET FROM THE PINCH WELD HOLE. REPEAT STEP 4.1 USING ANGLE BRKT.
6. ATTACH INBOARD BRACKET (ITEM# 12 LH & ITEM# 13 RH) AND OUTBOARD BRACKET (ITEM# 11) TOGETHER USING 5/16" X 1.00" BLACK ZINC PLATED HEX HEAD CAP SCREW (ITEM# 2) AND 5/16" BLACK ZINC PLATED FLAT WASHERS (ITEM# 3) AND SERRATED FLANG NUT BLACK ZINC (ITEM# 4). FINGER TIGHT ONLY UNTIL BOARD IS POSITIONED.
 - 6.1 REMOVE FACTORY NUT FROM SHACKLE MOUNT. PLACE BRACKET OVER STUD AND REPLACE FACTORY NUT. FINGER TIGHTEN ONLY.



INSTALLATION INSTRUCTIONS AND PARTS LIST

APPLICATION:

MODEL 400929 WHEEL TO WHEEL STEP BRACKETS:

2009 FORD F-150 REGULAR / SUPER CAB / SUPERCREW CAB PICKUPS

7. ATTACHING THE STEP ASSEMBLY:

PLEASE REVIEW THE INSTALLATION INSTRUCTIONS THAT ARE INCLUDED IN YOUR STEP ASSEMBLY FOR SPECIFIC DETAILS.

TORQUE ALL 5/16" FASTENERS TO 19 LB FT.

TORQUE THE 3/4" FASTENERS TO 65 LB FT.

SERVICE PARTS LIST

ITEM	PART NO.	QTY	DESCRIPTION
PARTS INCLUDED IN THE BRACKET PACKAGE			
1	551851	8	MOUNTING BRACKET, BLK, F150, GRIP STEP
2	106997	12	SCREW- HEX HEAD CAP, 5/16_18 UNC X 1.00", SST, BZP
3	106998	12	WSHR-PL, A, SST, 5/16,.375 ID X .875 OD X .083 THK, BZP
4	106996	4	NUT-FLG,HEX,SST,5/16-18 BZP
5	102680	10	NUT-SERR FLG,HX,SST,WX,5/16-18
6	104264	4	U-NUT- MULTI THREAD, 5/16-18 UNC, STL, BLK
7	551559	2	BRKT-MTG,ANGLE, 09 F-150
8	100647	6	SCREW- HEX HEAD CAP, 5/16_18 UNC X 1.00".ZP
9	100034	6	WSHR-PL, A, STL, 5/16,.375 ID X .875 OD X .083 THK, ZP
10	104267	4	5/16"X3/4" SELF TAPPING SCREW
11	552125	2	BRKT-STEP, REAR,OUTBOARD
12	551875	1	BRKT-STEP, REAR, INBOARD, LH, W2W, GRIP STEP
13	551876	1	BRKT-STEP, REAR, INBOARD, RH, W2W,GRIP STEP

SERVICE PARTS LIST

MODEL NO. - 400929

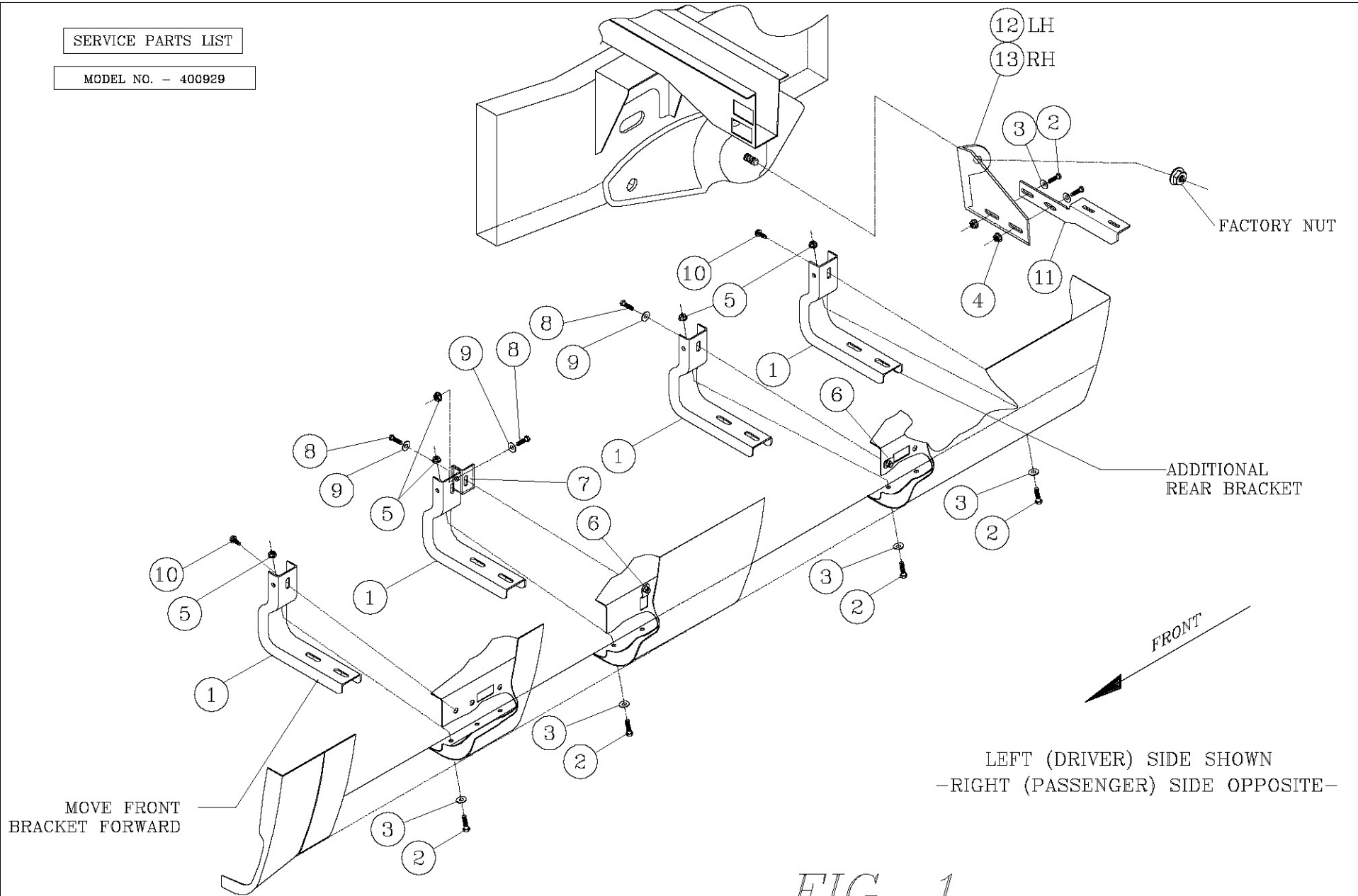

FIG. 1



Choose reliable running boards offered on our website.