

INSTALLATION INSTRUCTIONS AND PARTS LIST

MODEL 415078, 415088, GRIP STEPS (BOARDS ONLY)

UNIVERSAL APPLICATIONS

1. Read instructions completely and check to make sure that all required parts (listed on the service parts list) are on hand before starting the installation.
2. Follow the instructions included with the specific bracket package that you are using to mount the brackets to your vehicle.
3. Step assembly:
 - 3.1 Before attaching the grip steps to the brackets, slide the appropriate number of support braces (item #2) into the channel of the step (item #1).
 - 3.2 Slide the end cap (item #3) over the front and rear of each step. Using the supplied #8 x 1/2" self drilling tek screw (item #8), screw the end cap to the bottom of the step.
4. Attaching the step to the mounting bracket:
 - 4.1 Set the step on the mounting brackets, and slide each support brace over the top of each mounting bracket. Attach the flat spacer plate (item #4) to the bottom of the step, between the support brace, and the top of the mounting bracket.
 - 4.2 Using the supplied 5/16-18 x 1" carriage bolt, washer, and flange nuts, (item #5, 6, 7), attach the step assembly, flat spacer plate and mounting bracket. **(NOTE: Some of the flange nuts are supplied in the specific bracket package, not the step package.)**
 - 4.3 Set the step plate in the correct position and tighten all fasteners.
Torque all 5/16" fasteners to 19 LB FT.

SERVICE PARTS LIST

ITEM	PART NO.	QTY	DESCRIPTION
1	551384	2	EXTRUSION-AL,77.62, GRIP STEP,BLK,415078
1	551385	2	EXTRUSION-AL,87.75,GRIP STEP,BLK,415088
2	551296	8	SUPPORT BRACE, UPPER, GALV
3	551394	4	CAP-END,GRIP STEP, BLACK, PLASTIC
4	551298	8	SPACER PLATE, LOWER, BLACK
5	108683	16	BOLT-CRG,5/16-18 X 1.0", SST
6	101369	16	WASHER-FLAT,5/16,SST
7	102680	16	NUT-SERR FLG,HX,SST,WX,5/16-18
8	107958	8	SCR-TEK #8-18 X 1/2",SST,BLK

LIVERNE
TRUCK EQUIPMENT

(A LIVERNE Company)

SERVICE PARTS LIST

MODEL NO. - 415078
- 415088

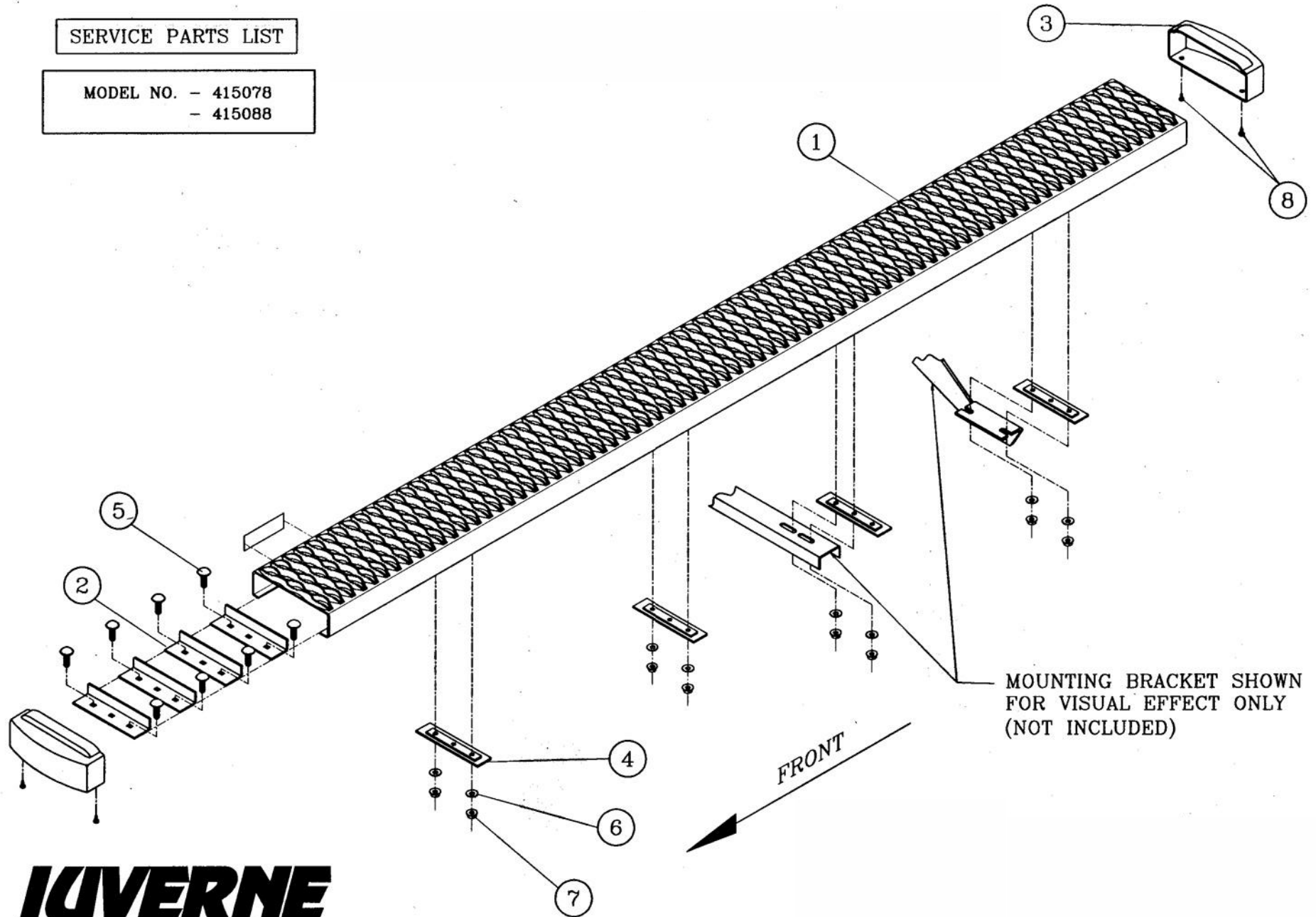

LIVERNE
TRUCK EQUIPMENT

(A LIVERNE Company)

INSTALLATION INSTRUCTIONS AND PARTS LIST

APPLICATION:

**MODEL 400829 WHEEL TO WHEEL STEP BRACKETS:
2008 AND NEWER FORD SUPER DUTY PICKUPS**



1. READ INSTRUCTIONS COMPLETELY AND CHECK TO MAKE SURE THAT ALL REQUIRED PARTS (LISTED ON THE SERVICE PARTS LIST) ARE ON HAND BEFORE STARTING THE INSTALLATION.
2. INSTALL 5/16" MULTI THREAD U-NUTS (ITEM #8) IN THE TOP REAR HOLE OF THE FIRST, SECOND AND THIRD PATTERNS AND IN THE FRONT TOP HOLE OF THE FIFTH OR REAR PATTERN AS SHOWN. INSTALL THESE U-NUTS SO THAT THE THREADS ARE TO THE INSIDE OF THE ROCKER PANEL. (THIS IS DONE BY INSERTING THE THREADED HALF OF THE U-NUT THRU THE LARGE ACCESS HOLES AND SLIDING THE U-NUT TOWARDS THE ROUND HOLE UNTIL IT SEATS IN THE ROUND HOLE).
3. ATTACH THE MOUNTING BRACKETS TO THE VEHICLE AS FOLLOWS: [SEE FIG. 1]
(NOTE: THE FRONT MOUNTING BRACKET, ITEM #1, HAS A 3/16" OFFSET AT THE TOP OF THE BRACKET).
 - 3.1. POSITION THE BRACKETS (ITEM #1,2) ON THE VEHICLE SO THAT THE TOP HOLE LINES UP WITH THE MULTI THREAD U-NUT AND THE BOTTOM HOLE LINES UP WITH THE HOLE IN THE PINCH WELD. ATTACH THE TOP OF THE BRACKET WITH A 5/16" X 1.00" ZINC PLATED HEX HEAD CAP SCREW (ITEM #6) AND 5/16" ZINC PLATED FLAT WASHER (ITEM #7). ATTACH THE BOTTOM OF THE BRACKET TO THE PINCH WELD WITH A 5/16" X 1.00" BLACK PLATED HEX HEAD CAP SCREW (ITEM #3), 5/16" BLACK PLATED FLAT WASHER (ITEM #4) AND 5/16" SERRATED FLANGE NUT (ITEM #5). LEVEL THE BRACKETS AND TIGHTEN THE BOLTS.
4. ATTACH THE REAR INBOARD MOUNTING BRACKET (ITEM #9) AGAINST THE TOP OF THE VEHICLE SPRING HANGER SO THAT THE FLAT SURFACES MEET AND THE SHORT LEG IS IN A VERTICAL POSITION.
 - 4.1. INSTALL 7/16-14X1-1/2 HEX HEAD SCREW AND FLAT WASHER (ITEM #11 & #13) DOWN THRU THE TOP OF BRACKET AND THE SPRING SHACKLE MOUNT. ATTACH THE 7/16-14 SERRATED FLANGE NUT AND WASHER (ITEM #12 AND #13).
 - 4.2. INSTALL THE BOTTOM OUTBOARD MOUNTING BRACKET (ITEM #10) SO THAT THE VERTICAL SURFACE MEETS THE INBOARD BRACKET. INSTALL (1) 3/8-16 DOUBLE ENDED STUD, (3) SERRATED 3/8-16 NUTS, (1) WASHER, AND (1) RUBBER WASHER (ITEM #14,15,16,17) THROUGH THE TOP MOUNTING LOCATION. POSITION THE RUBBER END SO THAT IT IS LOCATED ON THE HEAD OF THE BOLT THAT FASTENS THE LEAF SPRING. THEN INSTALL (2) 5/16-18 1.00 HEX HEAD CAP, WASHER AND SERRATED FLANGE NUT (ITEM #6,7,&5). FINGER TIGHTEN THESE FASTENERS UNTIL THE STEP IS IN PLACE.
5. ATTACHING THE STEP ASSEMBLY:
PLEASE REVIEW THE INSTALLATION INSTRUCTIONS THAT ARE INCLUDED IN YOUR STEP ASSEMBLY FOR SPECIFIC DETAILS.

TORQUE THE 5/16" FASTENERS TO 19 LB FT.
TORQUE THE 7/16" FASTENERS TO 40 LB FT.



INSTALLATION INSTRUCTIONS AND PARTS LIST

APPLICATION:

**MODEL 400829 WHEEL TO WHEEL STEP BRACKETS:
2008 AND NEWER FORD SUPER DUTY PICKUPS**

SERVICE PARTS LIST

ITEM	PART NO.	QTY	DESCRIPTION
1	551855	2	BRKT- MTG, STEP, SUPER DUTY PICKUP, FRONT
2	551854	6	BRKT- MTG, STEP, SUPER DUTY PICKUP
3	106997	8	SCREW- HEX HEAD CAP, 5/16_18 UNC X 1.00", SST, BZP
4	106998	8	WSHR-PL, A, SST, 5/16,.375 ID X .875 OD X .083 THK, BZP
5	102680	10	NUT-SERRATED FLANGE, HEX, SST, 5/16-18 UNC
6	100647	10	SCREW- HEX HEAD CAP, 5/16_18 UNC X 1.00".ZP
7	100034	10	WSHR-PL, A, STL, 5/16,.375 ID X .875 OD X .083 THK, ZP
8	104264	8	U-NUT- MULTI THREAD, 5/16-18 UNC, STL, BLK
9	551642	2	BRKT-MTG, W2W, 12 GA, 2.00", FORD SPR DTY,INBOARD
10	551878	2	BRKT-MTG, W2W, FORD SPR DTY,LOWER, OUTBOARD
11	100070	2	SCREW- HEX HEAD CAP, 7/16-14X1-1/2", ZP
12	103737	2	NUT-SERRATED FLANGE,HEX7/16-14 UNC,ZP
13	100081	4	WSHR-FL, A, STL, 7/16,..464X1.243X.064 THK, ZP
14	100062	2	WASHER-FLAT, 3/8", ZP
15	102592	2	WASHER-RUBBER,.354 ID X 1.00 OD X .75 THK
16	104687	2	STUD-DOUBLE ENDED, STL,3/8-16 INC X 7.00",ZP
17	100181	6	NUT-SERRATED FLANGE, HEX, SST, 3/8-16 UNC, ZP



SERVICE PARTS LIST

BRACKET NO. - 400829

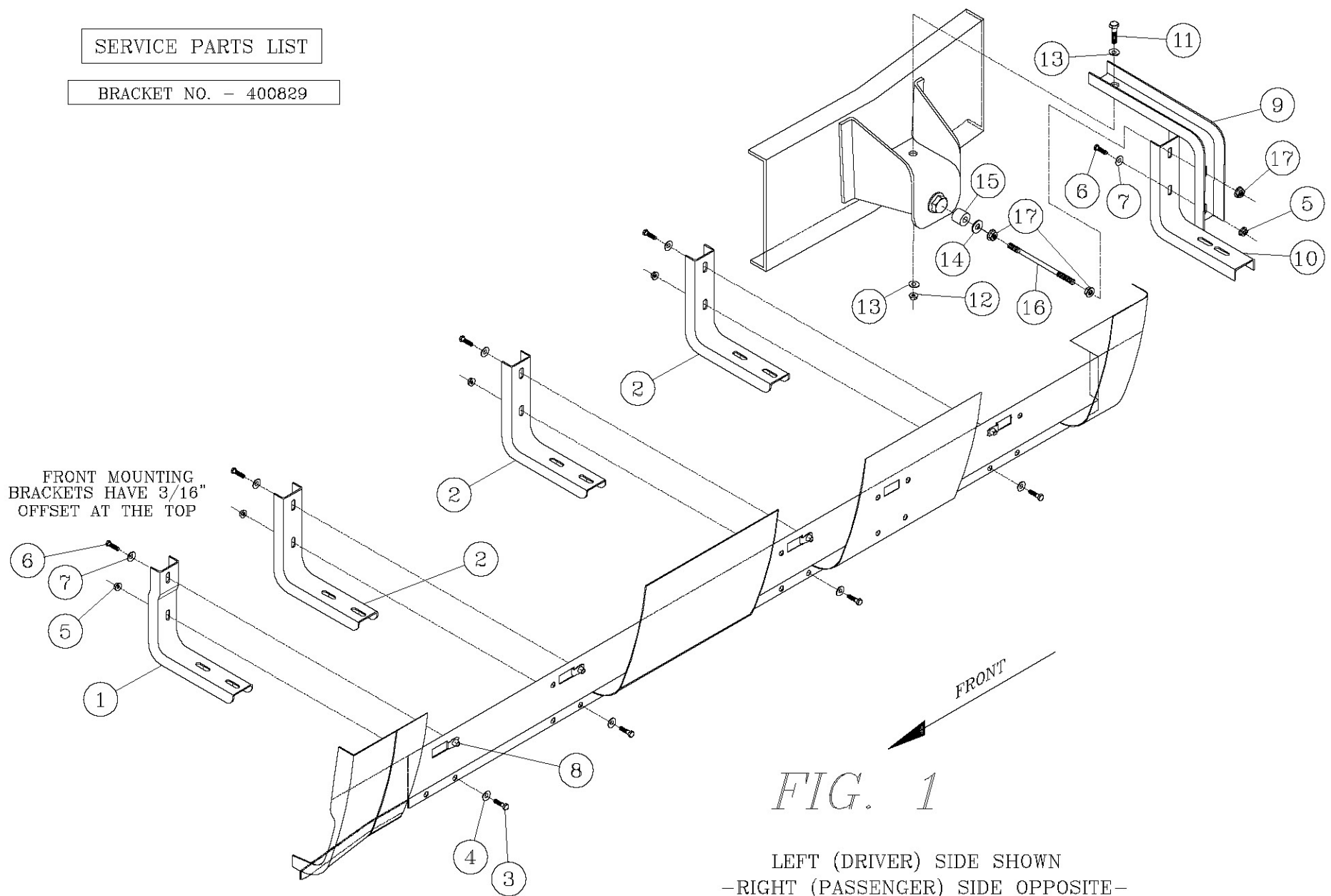

FIG. 1

LEFT (DRIVER) SIDE SHOWN
-RIGHT (PASSENGER) SIDE OPPOSITE-

