

INSTALLATION INSTRUCTIONS AND PARTS LIST

MODEL 415078, 415088, GRIP STEPS (BOARDS ONLY)

UNIVERSAL APPLICATIONS

1. Read instructions completely and check to make sure that all required parts (listed on the service parts list) are on hand before starting the installation.
2. Follow the instructions included with the specific bracket package that you are using to mount the brackets to your vehicle.
3. Step assembly:
 - 3.1 Before attaching the grip steps to the brackets, slide the appropriate number of support braces (item #2) into the channel of the step (item #1).
 - 3.2 Slide the end cap (item #3) over the front and rear of each step. Using the supplied #8 x 1/2" self drilling tek screw (item #8), screw the end cap to the bottom of the step.
4. Attaching the step to the mounting bracket:
 - 4.1 Set the step on the mounting brackets, and slide each support brace over the top of each mounting bracket. Attach the flat spacer plate (item #4) to the bottom of the step, between the support brace, and the top of the mounting bracket.
 - 4.2 Using the supplied 5/16-18 x 1" carriage bolt, washer, and flange nuts, (item #5, 6, 7), attach the step assembly, flat spacer plate and mounting bracket. **(NOTE: Some of the flange nuts are supplied in the specific bracket package, not the step package.)**
 - 4.3 Set the step plate in the correct position and tighten all fasteners.
Torque all 5/16" fasteners to 19 LB FT.

SERVICE PARTS LIST

ITEM	PART NO.	QTY	DESCRIPTION
1	551384	2	EXTRUSION-AL,77.62, GRIP STEP,BLK,415078
1	551385	2	EXTRUSION-AL,87.75,GRIP STEP,BLK,415088
2	551296	8	SUPPORT BRACE, UPPER, GALV
3	551394	4	CAP-END,GRIP STEP, BLACK, PLASTIC
4	551298	8	SPACER PLATE, LOWER, BLACK
5	108683	16	BOLT-CRG,5/16-18 X 1.0", SST
6	101369	16	WASHER-FLAT,5/16,SST
7	102680	16	NUT-SERR FLG,HX,SST,WX,5/16-18
8	107958	8	SCR-TEK #8-18 X 1/2",SST,BLK

LIVERNE
TRUCK EQUIPMENT

(A LIVERNE Company)

SERVICE PARTS LIST

MODEL NO. - 415078
- 415088

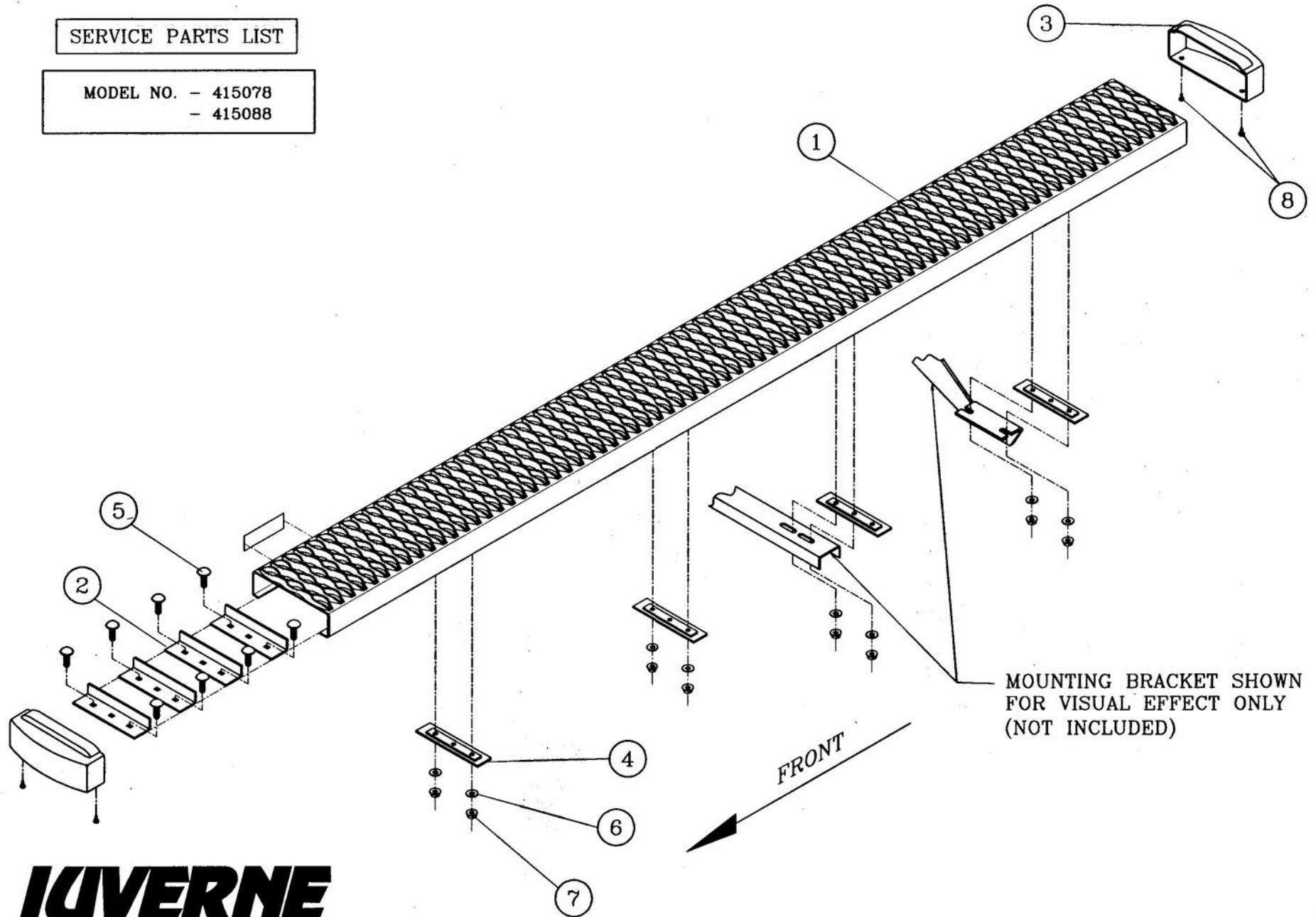

LIVERNE
TRUCK EQUIPMENT

(A LIVERNE Company)

INSTALLATION INSTRUCTIONS AND PARTS LIST

MODEL 400752 STEP BRACKETS:

2007 AND NEWER TOYOTA TUNDRA DOUBLE CAB & CREW MAXX PICKUPS



1. READ INSTRUCTIONS COMPLETELY AND CHECK TO MAKE SURE THAT ALL REQUIRED PARTS (LISTED ON SERVICE PARTS LIST) ARE ON HAND BEFORE STARTING THE INSTALLATION.

2. ATTACH THE MOUNTING BRACKETS TO THE VEHICLE USING EXISTING MOUNTING HOLES ON THE INTERIOR WALL OF THE ROCKER PANEL. **(NOTE: THE BRACKETS MUST BE PLACED IN THE PROPER POSITION. THEY ARE IDENTIFIED WITH NOTCHES ON THE INBOARD EDGE. [1 NOTCH IS FOR #1 BRACKET, ETC.] #1 WILL BE AT THE FRONT OF THE VEHICLE. SEE FIG. 1).**
 - 2.1. POSITION THE BRACKETS ON THE VEHICLE SO THAT BOTH HOLES LINE UP WITH THE THREADED INSERTS IN THE ROCKER PANEL. ATTACH THE TOP OF THE BRACKET WITH A M8-1.25 X 25MM ZINC PLATED HEX HEAD CAP SCREW, 5/16" FLAT WASHER AND LOCK WASHER (ITEMS #5, #6 & #7). LEVEL THE BRACKETS AND TIGHTEN THE FASTENERS TO 19 LB FT.

3. ATTACHING THE STEP ASSEMBLY:
PLEASE REVIEW THE INSTALLATION INSTRUCTIONS THAT ARE INCLUDED IN YOUR STEP ASSEMBLY FOR SPECIFIC DETAILS.

SERVICE PARTS LIST

ITEM	PART NO.	QTY	DESCRIPTION
1	551985	2	BRKT- MTG, STEP, #1, TOYOTA TUNDRA
2	551986	2	BRKT- MTG, STEP, #2, TOYOTA TUNDRA
3	551987	2	BRKT- MTG, STEP, #3, TOYOTA TUNDRA
4	551988	2	BRKT- MTG, STEP, #4, TOYOTA TUNDRA
5	102549	16	SCREW-M8-1.25X25MM,ZP
6	100030	16	WHSR-LOCK, 5/16" ZP
7	100034	16	WHSR-FLAT, 5/16" ZP

SERVICE PARTS LIST

MODEL NO. - 400752

NOTE: NOTCHES IN THE BACK OF EACH BRACKET ARE THERE TO INDICATE BRACKET LOCATION #1 BEING THE FRONT BRACKET, AND #4 BEING THE REAR BRACKET

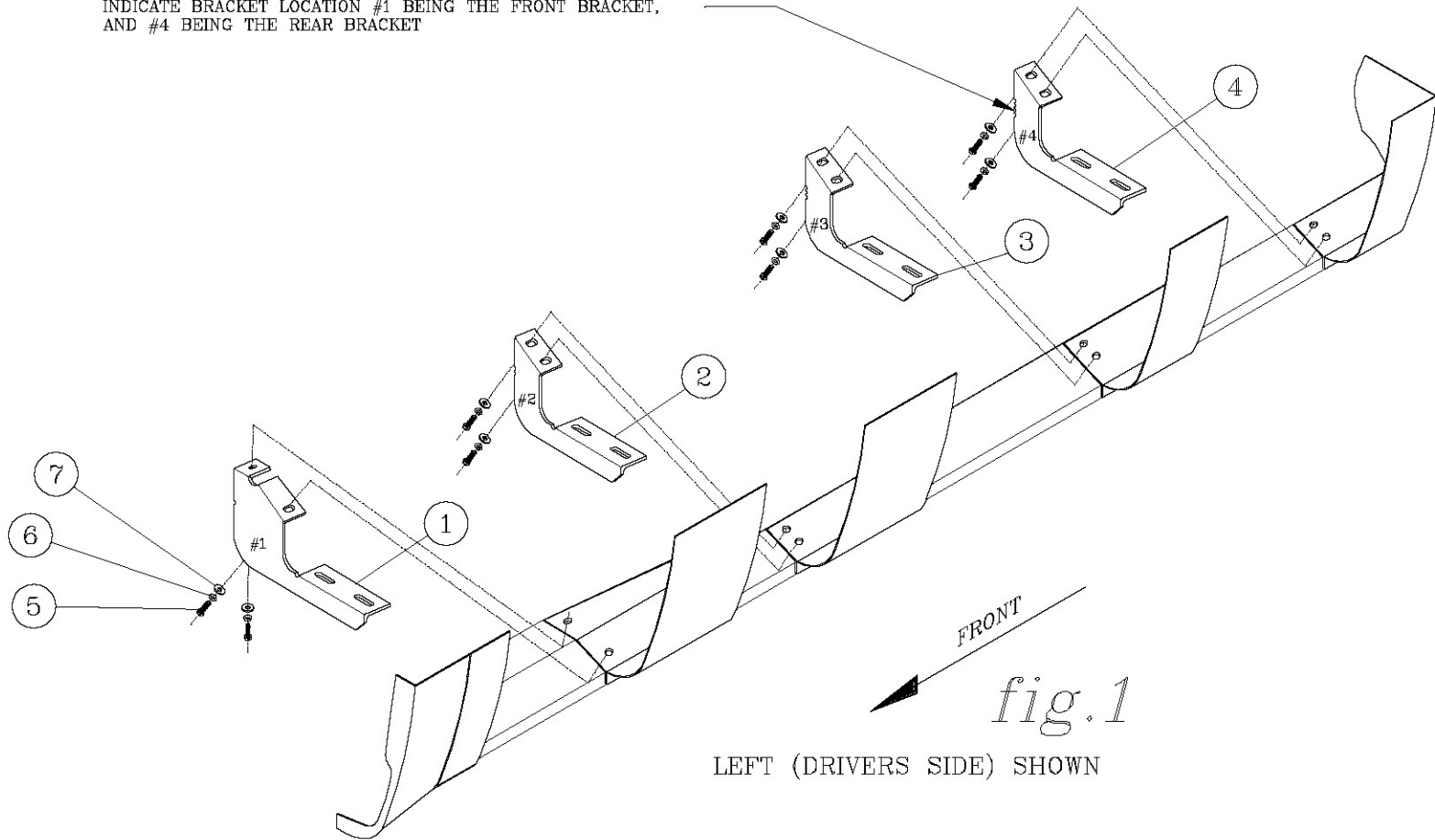

Choose reliable running boards offered on our website.