

INSTALLATION INSTRUCTIONS AND PARTS LIST

MODEL 415078, 415088, GRIP STEPS (BOARDS ONLY)

UNIVERSAL APPLICATIONS

1. Read instructions completely and check to make sure that all required parts (listed on the service parts list) are on hand before starting the installation.
2. Follow the instructions included with the specific bracket package that you are using to mount the brackets to your vehicle.
3. Step assembly:
 - 3.1 Before attaching the grip steps to the brackets, slide the appropriate number of support braces (item #2) into the channel of the step (item #1).
 - 3.2 Slide the end cap (item #3) over the front and rear of each step. Using the supplied #8 x 1/2" self drilling tek screw (item #8), screw the end cap to the bottom of the step.
4. Attaching the step to the mounting bracket:
 - 4.1 Set the step on the mounting brackets, and slide each support brace over the top of each mounting bracket. Attach the flat spacer plate (item #4) to the bottom of the step, between the support brace, and the top of the mounting bracket.
 - 4.2 Using the supplied 5/16-18 x 1" carriage bolt, washer, and flange nuts, (item #5, 6, 7), attach the step assembly, flat spacer plate and mounting bracket. **(NOTE: Some of the flange nuts are supplied in the specific bracket package, not the step package.)**
 - 4.3 Set the step plate in the correct position and tighten all fasteners.
Torque all 5/16" fasteners to 19 LB FT.

SERVICE PARTS LIST

ITEM	PART NO.	QTY	DESCRIPTION
1	551384	2	EXTRUSION-AL,77.62, GRIP STEP,BLK,415078
1	551385	2	EXTRUSION-AL,87.75,GRIP STEP,BLK,415088
2	551296	8	SUPPORT BRACE, UPPER, GALV
3	551394	4	CAP-END,GRIP STEP, BLACK, PLASTIC
4	551298	8	SPACER PLATE, LOWER, BLACK
5	108683	16	BOLT-CRG,5/16-18 X 1.0", SST
6	101369	16	WASHER-FLAT,5/16,SST
7	102680	16	NUT-SERR FLG,HX,SST,WX,5/16-18
8	107958	8	SCR-TEK #8-18 X 1/2",SST,BLK

LIVERNE
TRUCK EQUIPMENT

(A LIVERNE Company)

SERVICE PARTS LIST

MODEL NO. - 415078
- 415088

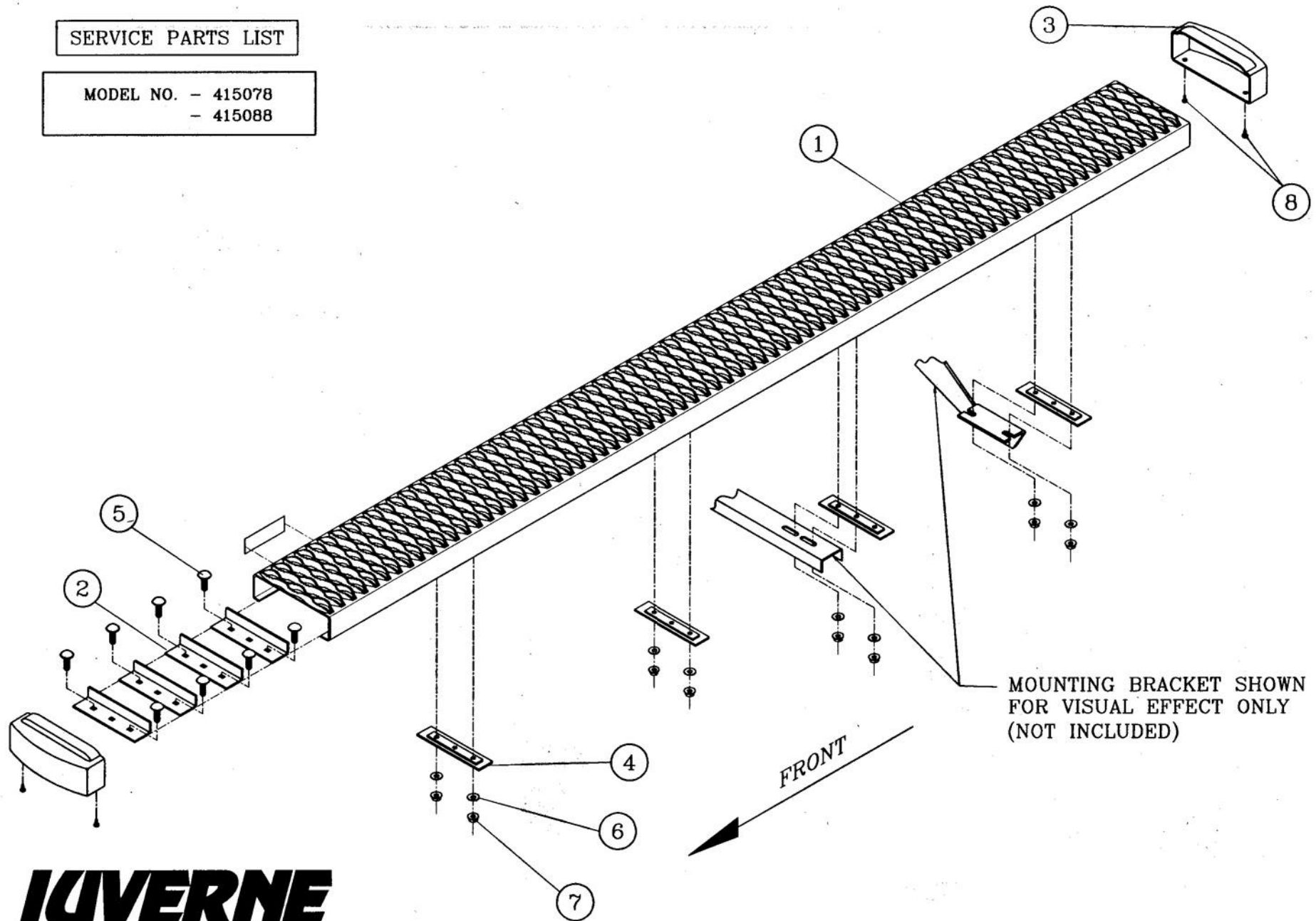

LIVERNE
TRUCK EQUIPMENT

(A LIVERNE Company)

INSTALLATION INSTRUCTIONS AND PARTS LIST

APPLICATION: **MODEL 401632 REGAL 7/GRIP STEP BRACKET KIT:**

2009+ DODGE RAM 1500 QUAD/CREW CAB PICKUPS

2010+ DODGE RAM HD CREW/MEGA CAB PICKUPS, & CHASSIS CABS.

1. READ INSTRUCTIONS COMPLETELY AND CHECK TO MAKE SURE THAT ALL REQUIRED PARTS (LISTED ON THE SERVICE PARTS LIST) ARE ON HAND BEFORE STARTING THE INSTALLATION.
2. ATTACH THE MOUNTING BRACKETS TO THE VEHICLE AS FOLLOWS:

RAM TRUCKS WITH THREADED INSERTS IN THE ROCKER PANEL.

- 2.1 PLACE THE DRIVERS SIDE FRONT BRACKET (ITEM #1) UP TO THE PINCHWELD SO THAT THE LOWER MOUNTING FLANGE IS TO THE OUTSIDE OF THE PINCHWELD, ALIGN THE TWO RECTANGULAR HOLES OF THE LOWER MOUNTING FLANGE OF (ITEM #1) WITH THE TWO OBOUND HOLES IN THE PINCHWELD, INSERT THE TWO 1/4-20 X 1" CARRIAGE BOLTS (ITEM #3) THROUGH THE LOWER MOUNTING FLANGE AND THEN THROUGH THE PINCHWELD, PLACE A 1/4" FLAT WASHER (ITEM #4), AND 1/4-20 FLANGE NUT (ITEM #5) ON TO THE CARRIAGE BOLTS, LEAVE FINGER TIGHT. **SEE FIGURES 1 & 2.**
- 2.2 INSERT AN M8 X 25mm SCREW (ITEM # 6) WITH A 5/16" FLAT WASHER (ITEM #7) THROUGH THE SLOTS ON THE UPPER MOUNTING FLANGE, LEAVE FINGER TIGHT.
- 2.3 REPEAT STEPS 2.1 & 2.2 ON THE MIDDLE, AND REAR BRACKETS (ITEM #2) .
- 2.4 FOR THE PASSENGER SIDE THE INSTALLATION IS A MIRROR IMAGE OF THE DRIVERS SIDE, USE (ITEM #2) FOR THE FRONT BRACKET, (ITEM #1) FOR THE MIDDLE, AND REAR BRACKET.

RAM TRUCKS WITHOUT THREADED INSERTS IN THE ROCKER PANEL.

- 2.5 ON THE VERTICAL WALL OF THE ROCKER PANEL, INSTALL THE T-BOLT WELDMENT (ITEM #9) INTO THE LARGE OBOUND HOLE INSERTING THE NUT END FIRST, LEAVING THE THREADED STUD STICKING OUT OF THE OBOUND HOLE. **BE CAREFULL NOT TO DROP THE T-BOLT INSIDE OF THE ROCKER PANEL.** ATTACH THE FLAT PLASTIC BOLT RETAINER (ITEM #10) TO THE THREADED STUD OF THE T-BOLT. (THIS IS TO KEEP THE T-BOLT FROM FALLING INTO THE ROCKER PANEL.)
- 2.6 PLACE THE DRIVERS SIDE FRONT BRACKET (ITEM #1) UP TO THE PINCHWELD SO THAT THE LOWER MOUNTING FLANGE IS TO THE OUTSIDE OF THE PINCHWELD, ALIGN THE TWO RECTANGULAR HOLES OF THE LOWER MOUNTING FLANGE OF (ITEM #1) WITH THE TWO OBOUND HOLES IN THE PINCHWELD, INSERT THE TWO 1/4-20 X 1" CARRIAGE BOLTS (ITEM #3) THROUGH THE LOWER MOUNTING FLANGE AND THEN THROUGH THE PINCHWELD, PLACE A 1/4" FLAT WASHER (ITEM #4), AND 1/4-20 FLANGE NUT (ITEM #5) ON TO THE CARRIAGE BOLTS, LEAVE FINGER TIGHT. **SEE FIGURES 3 & 4.**
- 2.7 PLACE A FLAT WASHER (ITEM #7), AND AN M8 FLANGE NUT (ITEM #8), ON THE THREADED STUD OF THE T-BOLT (ITEM #9) LEAVE FINGER TIGHT.
- 2.8 ROTATE THE T-BOLT SO THAT THE THREADED NUT IS VISIBLE THROUGH THE SLOTTED HOLE IN THE UPPER MOUNTING FLANGE, INSERT AN M8 X 25mm SCREW (ITEM #6) WITH A 5/16" FLAT WASHER (ITEM #7), LEAVE FINGER TIGHT.
- 2.9 REPEAT STEPS 2.5 THRU 2.8 ON THE MIDDLE AND REAR BRACKETS (ITEM #2).
- 2.10 FOR THE PASSENGER SIDE THE INSTALLATION IS A MIRROR IMAGE OF THE DRIVERS SIDE, USE (ITEM #2) FOR THE FRONT BRACKET, (ITEM #1) FOR THE MIDDLE, AND REAR BRACKET.

NOTE: 2009 TO 2012 TRUCKS DO NOT HAVE THE OBOUND HOLES IN THE PINCH WELD, THEY WILL REQUIRE DRILLING (2) 5/16" HOLES FOR EACH BRACKET, TO GET THE PROPER LOACTION FOR DRILLING FOLOW STEP 2.5, AND THEN SKIP TO STEP 2.7 & 2.8, WITH THE BRACKET IN PLACE, NOW MARK THE PINCHWELD FOR DRILLING.

3. INSTALL THE STEP PLATES, AND ADJUST BRACKETS, AND BOARDS BEFORE TIGHTENING ALL THE FASTENERS.



SERVICE PARTS LIST

ITEM	PART NO.	QTY	DESCRIPTION
1	553092	3	BRKT-MTG, WLDMNT, FRONT LH, MID RH. 401632
2	553093	3	BRKT-MTG, WLDMNT, FRONT RH, MID LH. 401632
3	101320	12	BLT-CRG, 1/4-20 X 1.00", SST, BLK, EM6219
4	101370	12	WSHR-FL, SST, .281 X .625 X .065
5	102366	12	NUT-FLG, HEX, 1/4-20, SST
6	102549	12	SCR-HEX HD, M8 X 1.25 X 25mm, ZP
7	100034	12	WSHR-FL, 5/16, ZP
8	105859	6	NUT HEX-FLG, M8 X 1.25, ZP
9	553012	6	T-BOLT WELDMNT, ZP, 571632
10	101572	6	BOLT RETAINER-PLASTIC, 8mm

SERVICE PARTS LIST

BRACKET NO. - 401632

INSTALLATION ON ROCKER PANELS WITHOUT THREADED INSERTS

Fig.3

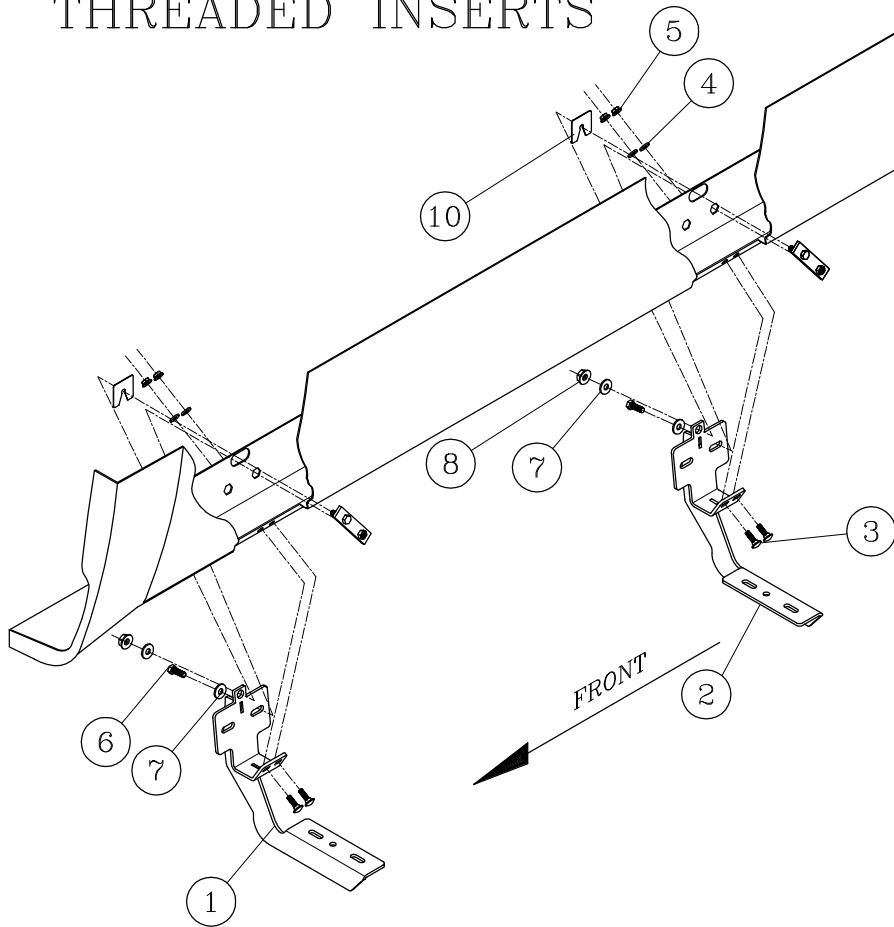

LEFT (DRIVER) SIDE SHOWN
-RIGHT (PASSENGER) SIDE OPPOSITE-

Fig.4

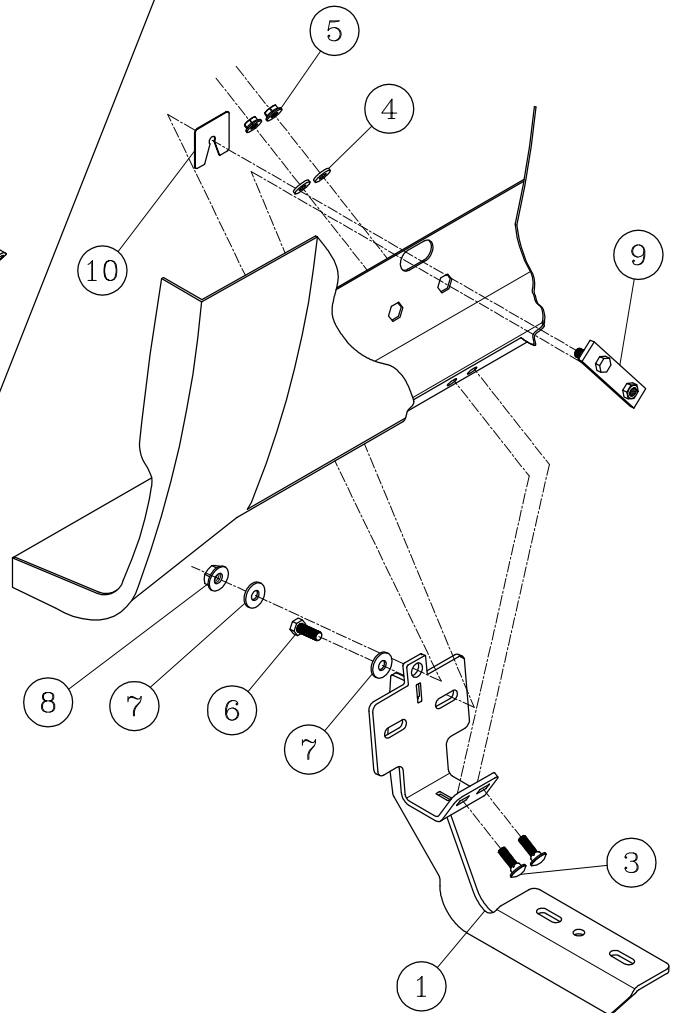

NOTE: 2009-12 WILL REQUIRE DRILLING THESE HOLES IN THE PINCHWELD.

SERVICE PARTS LIST

BRACKET NO. - 401632

INSTALLATION ON ROCKER PANELS WITH THREADED INSERTS

Fig.1

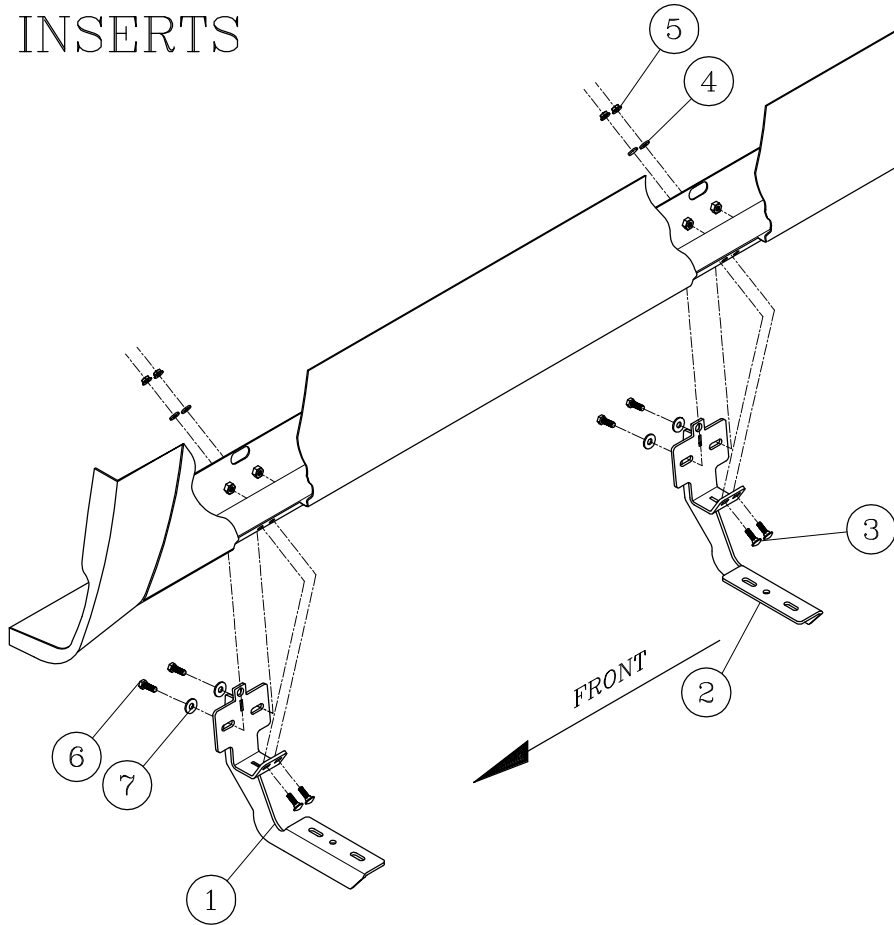

LEFT (DRIVER) SIDE SHOWN
-RIGHT (PASSENGER) SIDE OPPOSITE-

Fig.2

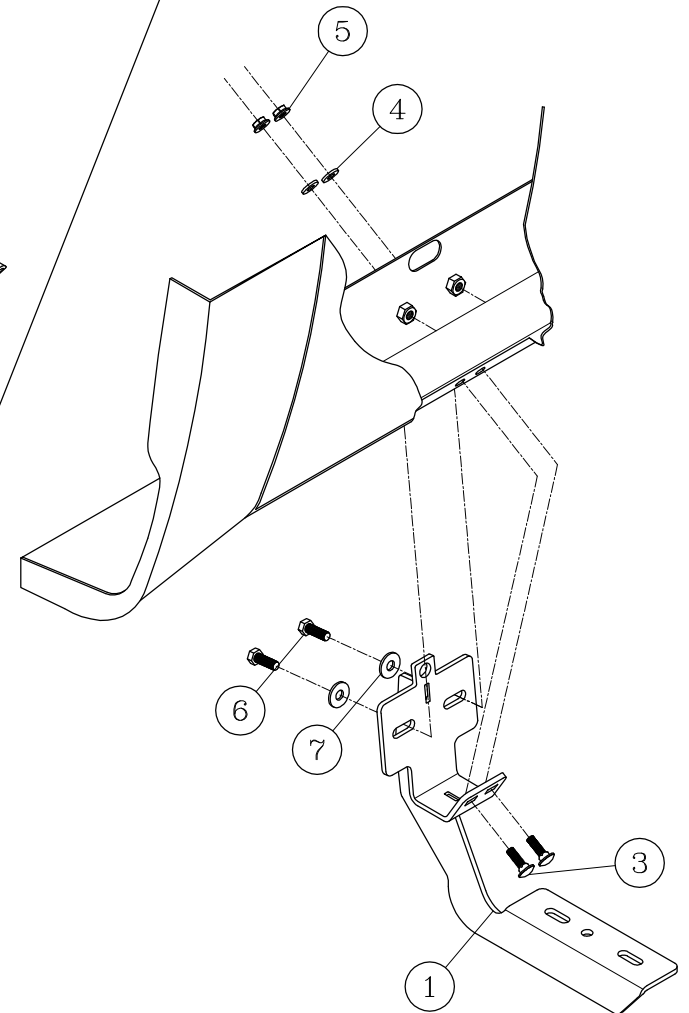

Choose reliable running boards offered on our website.