

# INSTALLATION INSTRUCTIONS AND PARTS LIST

## MODEL 585036, 586036 O-MEGA STEPS

1. READ INSTRUCTIONS COMPLETELY AND CHECK TO MAKE SURE THAT ALL REQUIRED PARTS (LISTED ON THE SERVICE PARTS LIST) ARE ON HAND BEFORE STARTING THE INSTALLATION.
2. FOLLOW THE INSTRUCTIONS INCLUDED WITH THE SPECIFIC BRACKET PACKAGE THAT YOU ARE USING, TO MOUNT THE BRACKETS TO YOUR VEHICLE.
3. BEFORE ATTACHING THE O-MEGA STEPS TO THE BRACKETS, MOUNT THE STEP PADS (ITEM #2) TO THE STEP PLATES USING THE 1/2" TEK SCREWS (ITEM #6) PROVIDED. POSITION THE STEP PAD ACCORDINGLY FOR YOUR VEHICLE. WHEN INSTALLING THE PADS ON THE STEPS, DRILL AND INSTALL THE TWO CENTER SCREWS FIRST. IF INSTALLING THE PADS WHEN THE TEMPERATURE IS AROUND 70° F., MAKE SURE THE SCREWS IN THE END SLOTTED HOLES ARE IN THE MIDDLE OF THE SLOT. WHEN TURNING IN THE SCREWS, TURN THEM IN SNUG THEN BACK OFF A ¼ TURN. PLASTIC WILL EXPAND WHEN IT IS HOT AND CONTRACT WHEN IT GETS COLD AND THE SLOT WILL ALLOW THIS TO HAPPEN WITHOUT RISING UP BETWEEN THE SCREWS.
4. INSTALL THE REQUIRED NUMBER OF SQUARE HEAD SCREWS (ITEM#4) INTO THE DESIGNATED SLOTS IN THE BOTTOM OF THE STEP PLATES.
5. INSTALL THE END CAPS (ITEM #3) AS SHOWN IN (FIG.1), TIGHTENING THE SERRATED NUTS (ITEM#5) TO 5 LB FT.
6. POSITION THE O-MEGA STEP ON THE MOUNTING BRACKETS SO THAT THE SQUARE HEAD SCREWS (ITEM #4) ARE LOCATED IN THE SLOTS OF THE MOUNTING BRACKETS AND THE STEP IS CENTERED, FRONT TO REAR, ON THE VEHICLE. INSTALL 5/16" SERRATED FLANGE NUTS (ITEM #5) ON THE SQUARE HEAD SCREWS (ITEM #4) AND TIGHTEN TO 19 LB FT.

## SERVICE PARTS LIST

ITEM	PART NO.	QTY	DESCRIPTION
1	551697	2	EXTRUSION-AL,33.00"OMEGA STP, SATIN
1	551698	2	EXTRUSION-AL,33.00"OMEGA STP, BLACK
2	107957	2	PAD-STEP PLATE, 4.50 X 20.00
3	107956	4	CAP-END,PLSTC,2.95 X 6.70
4	106880	16	SCREW-SQ HD,5/16-18 X 1,MAGNIGUARD
5	102680	16	NUT-SERR FLG,HX,SST,WX,5/16-18
6	107958	12	SCREW-PPH,TEK,#8-18 X 1/2",SST,BZP



SERVICE PARTS LIST

BRACKET NO. - 585036/586036

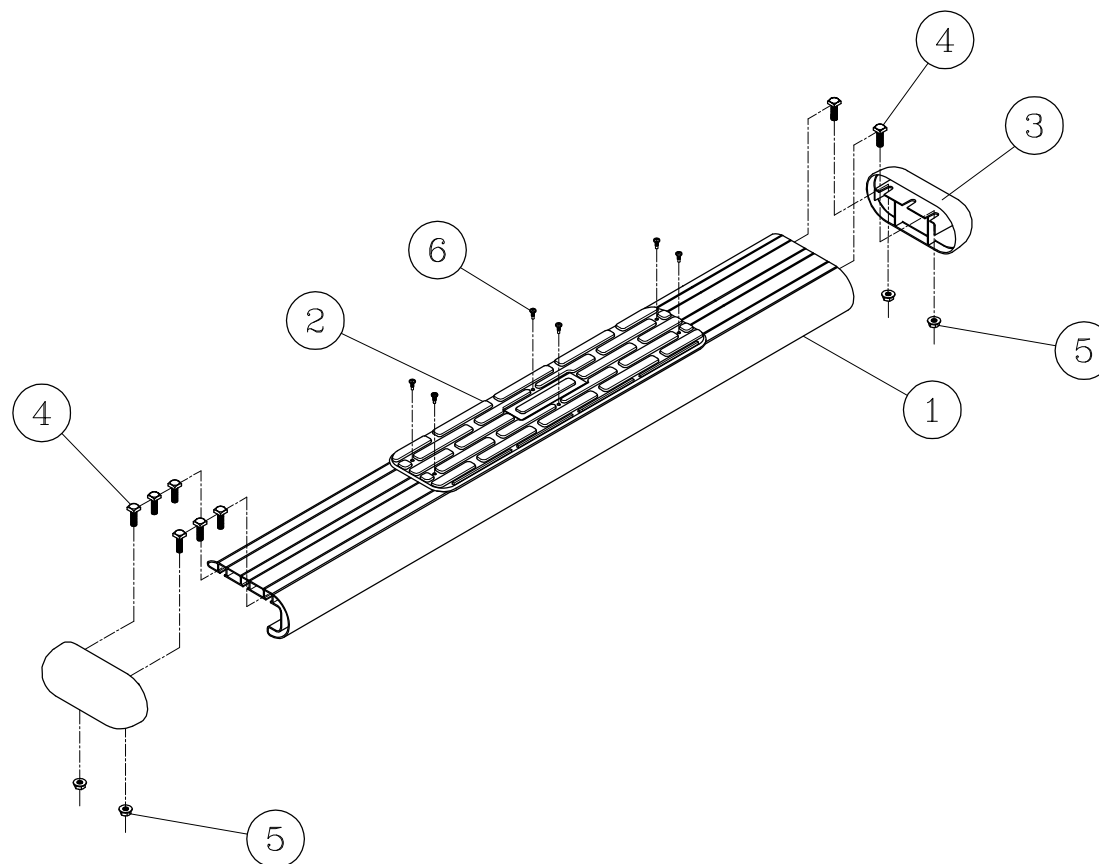

fig.1

# INSTALLATION INSTRUCTIONS AND PARTS LIST

FOR MOUNTING 401471/571471 MEGA/GRIP STEPS  
2014-NEWER RAM PROMASTER VANS

READ INSTRUCTIONS COMPLETELY AND CHECK TO MAKE SURE THAT ALL REQUIRED PARTS  
(LISTED ON SERVICE PARTS LIST) ARE ON HAND BEFORE STARTING THE INSTALLATION.

## **DRIVERS SIDE INSTALLATION**

1. PREASSEMBLE BRACKETS (ITEM 1) WITH SPACER BRACKETS (ITEM 6), USING THE 5/16-18 BOLTS WITH THE 5/16" WASHERS AND THE FLANGE NUTS (ITEMS #7, 12 & 13). FINGER TIGHTEN THEM ONLY AT THIS TIME.
2. MARK THE PINCH WELD FOR THE FRONT HOLE OF EACH BRACKET AS SHOWN IN FIG. 3.
3. ATTACHING THE FRONT BRACKET:
  - 3.1 TAKING THE BRACKET ASSEMBLY LINE IT UP THE BRACKET WITH THE HOLE MARKED AND MARK THE OTHER HOLE. REMOVE THE BRACKET ASSEMBLY AND DRILL THE MARKED LOCATIONS USING AN 11/32 DRILL BIT.
  - 3.2 FASTEN THE BRACKET TO THE PINCH WELD USING THE SUPPLIED FASTENERS. (ITEM #4, 10, 11 & 13)
  - 3.3 THE TOP HOLE WILL BE DRILLED AT A LATER TIME.
4. ATTACHING THE REAR BRACKET:
  - 4.1 LOCATE THE VERTICAL BODY LINE DIRECTLY BEHIND THE DRIVERS DOOR, FOLLOW THAT LINE DOWN TO THE PINCH WELD. THE REAR BRACKET (ITEM #2) WILL MOUNT BEHINED THAT LINE. AS SHOWN IN FIG. 3.
  - 4.2 PLACE THE REAR BRACKET (ITEM #2) UP TO THE INSIDE OF THE PINCH WELD AND SECURE IT USING A CLAMP. SOME UNDER COATING WILL NEED TO BE SCRAPPED OFF SO THE BRACKET WILL SIT FLAT WITH THE PINCH WELD.
  - 4.3 USING THE HOLES AS A REFERENCE, MARK THE CENTER OF ALL (4) HOLES AND REMOVE THE BRACKET FOR DRILLING. THE TWO HOLES MARKED ON THE PINCH WELD ALONG WITH THE HOLE MARKED TOWARD THE REAR OF THE VEHICLE ON THE ANGLED SURFACE WILL BE DRILLED WITH A 11/32 DRILL BIT, WHILE THE LAST HOLE TOWARD THE FRONT OF THE VEHICLE ON THE ANGLED SURFACE WILL BE DRILLED WITH A 3/16 DRILL BIT.
  - 4.4 REMOVE THE BODY PLUG ON THE ANGLED SURFACE TOWARD THE REAR OF THE VEHICLE, A 11/32 HOLE SHOULD HAVE BEEN DRILLED NEAR THE BODY PLUG. SOME UNDER COATING WILL NEED TO BE REMOVED SO THAT THE ¼-20 U-NUT (ITEM #8) WILL SLIDE IN PLACE OVER THE 11/32 HOLE.
  - 4.6 PLACE THE BRACKET (ITEM # 2) AND FASTEN THE BRACKET TO THE PINCH WELD USING THE 5/16-18 BOLTS, WASHERS, NUTS, AND RETAINER PLATE (ITEM #5,7,12 & 13). LEAVE THEM LOOSE AT THIS TIME. LOCATE THE U-NUT (ITEM #8) AND FASTEN USING THE ¼-20 BOLT AND WASHER (ITEM #14 &15). LOCATE THE 3/16 HOLE AND FASTEN USING THE 5/16 X ¾ SELF TAPPING SCREW (ITEM #9)
  - 4.7 TIGHTEN ALL FASTENERS FOR THE REAR BRACKET AT THIS TIME.



(A LUVERNE Company)

5. DRILLING THE TOP HOLE OF THE FRONT BRACKET.

5.1 PLACE A STRAIGHT EDGE ON THE FLAT PLACE OF THE REAR BRACKET (ITEM #2), HAVE THE STRAIGHT EDGE SITTING LEVEL WITH THE VEHICLE AND MOVE THE FRONT BRACKET UP OR DOWN SO THAT THE FLAT SURFACE IS LEVEL WITH THE STRAIGHT EDGE. FASTEN THE FRONT BRACKET WITH THE SPACER BRACKET SO THAT THEY ARE SNUG. LOCATE THE TOP HOLE OF THE FRONT BRACKET (ITEM #1) AND MARK THE CENTER OF THE HOLE. REMOVE THE BRACKET ASSEMBLY AND USING AN 11/32 DRILL LOCATE THE MARK THAT WAS MADE AND DRILL THE HOLE. REMOVE THE BODY PLUG LOCATED JUST NEXT TO WHERE THE HOLE WAS DRILLED. INSTALL THE U-NUT (ITEM #8) THROUGH THE BODY PLUG HOLE AND POSITION IT OVER THE 11/32 HOLE. (SOME UNDER COATING MAY NEED TO BE REMOVED IN ORDER TO INSTALL THE U-NUT PROPERLY). REINSTALL THE PREASSEMBLED BRACKET USING THE FASTENERS FOR THE PINCH WELD AREA (ITEM # 10, 11, &13) AND USING THE SUPPLIED FASTENERS FOR THE INNER ROCKER PANEL AREA (ITEM# 14 & 15). TIGHTEN ALL FASTENERS AT THIS TIME.

**PASSANGER SIDE INSTALLATION**

1. ATTACHING THE BRACKETS WILL BE THE SAME AS THE DRIVERS SIDE, STEPS 2 THRU 4 ALTHOUGH THE REAR BRACKET WILL BE ITEM #3.

**SERVICE PARTS LIST**

ITEM	PART NO.	QTY	DESCRIPTION
1	552430	2	BRACKET-MTG, PROMSTR,12 GA, LH/RH, MEGA
1	552405	2	BRACKET-MTG, PROMSTR,12 GA, LH/RH, GRIP
2	552431	1	MTG-BRKT, MIDDLE LH, MEGA
2	552407	1	MTG-BRKT, MIDDLE LH, GRIP
3	552432	1	MTG-BRKT, MIDDLE RH. MEGA
3	552408	1	MTG-BRKT, MIDDLE RH. GRIP
4	552289	2	RETAINER PLATE, GALV
5	552410	2	RETAINER PLATE, GALV
6	552288	2	SPACER BRACKET, 7 GA, LH/RH
7	100034	8	WASHER-FL, 5/16, ZP
8	106604	4	NUT-U, MULTI THD, LG, 1/4-20, BLK
9	104267	2	SCR-HWH, TF, AB, SST, 5/16 X .750
10	106997	4	SCR-HHCAP, 5/16-18 X 1.00, SST, BZP
11	106998	4	WASHER-FL, 5/16, BZP
12	100647	6	SCR-HEX HD, 5/16-18 X 1.00 STL, ZP
13	100178	12	NUT-HEX FLG, 5/16-18
14	100006	4	SCR-HEX HD, 1/4-20 X .750, ZP
15	100016	4	WASHER-FL, 1/4, ZP



SERVICE PARTS LIST

BRACKET NO. - 401471

fig. 2

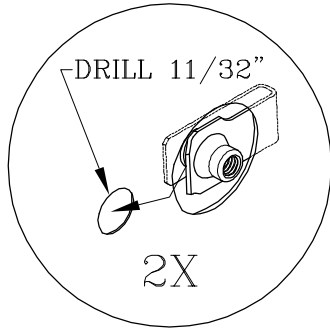
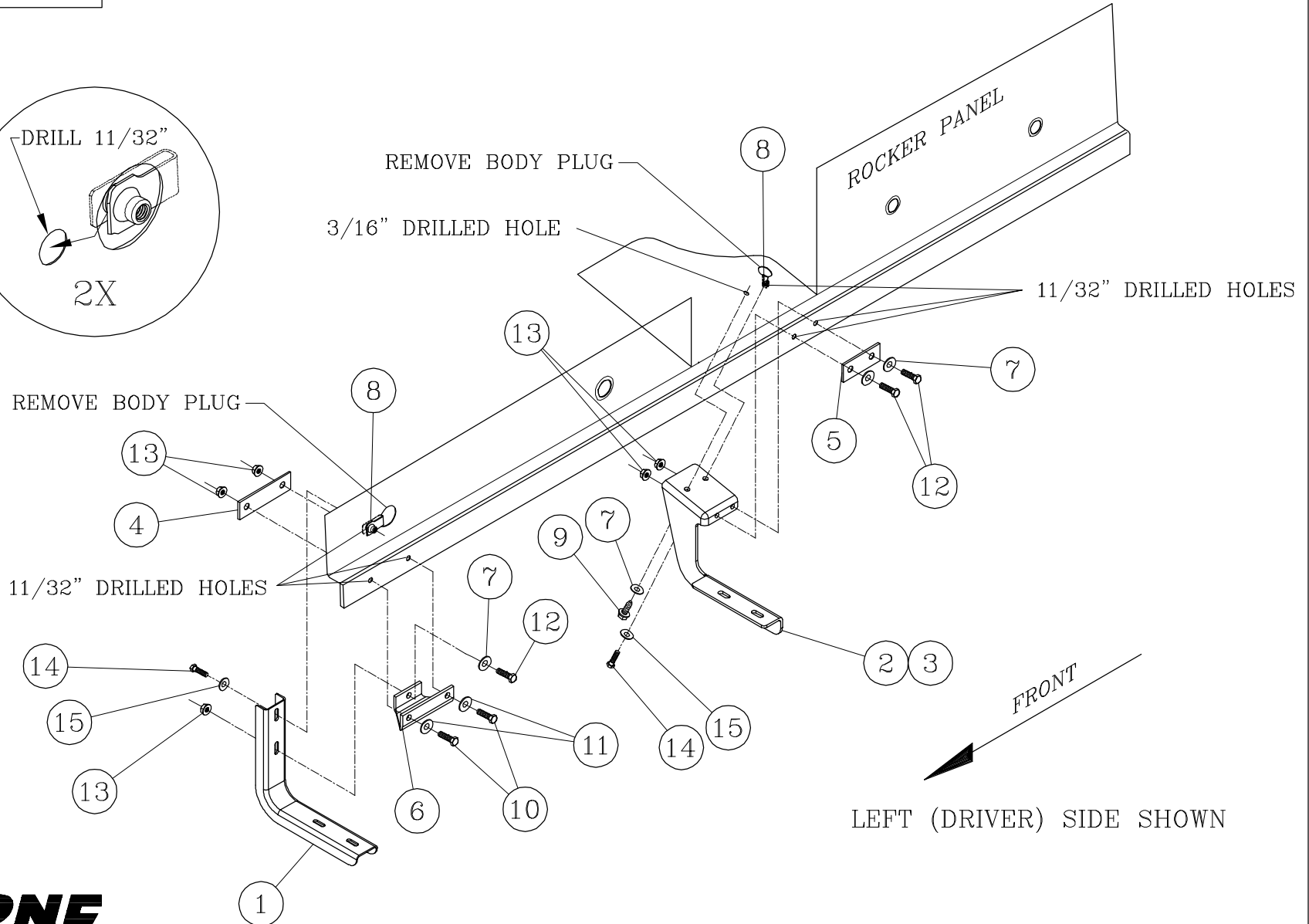

fig. 1



SERVICE PARTS LIST

BRACKET NO. - 401471

DRIVERS AND PASSANGER SIDE WILL  
USE THE SAME DIMENSIONS

fig. 3

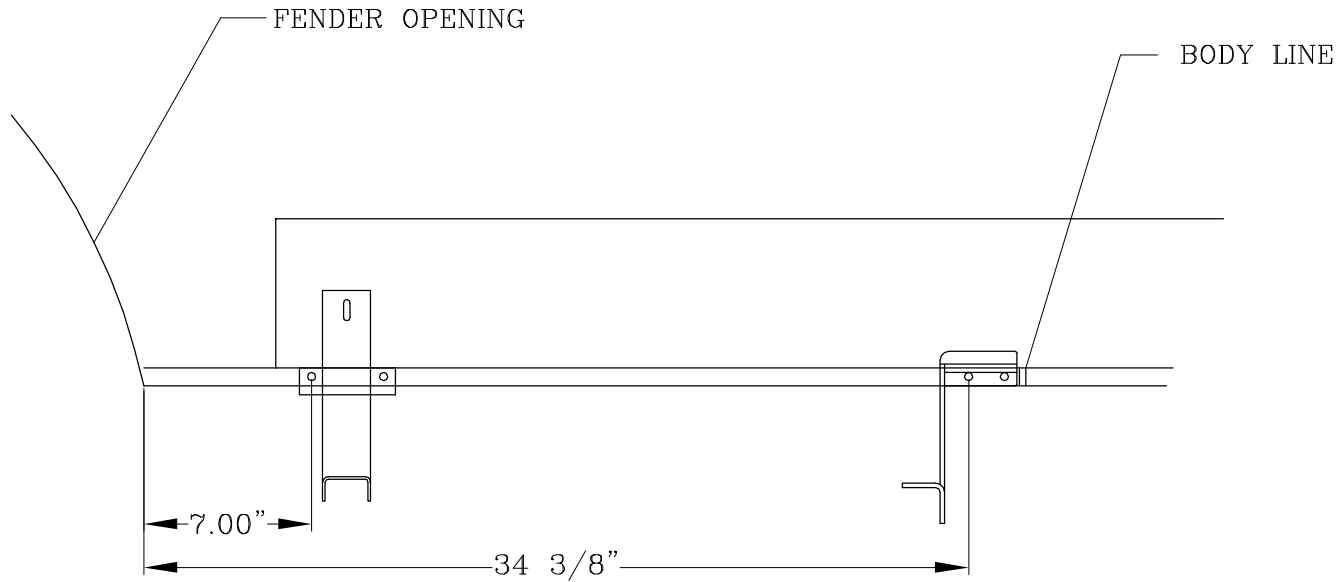

LEFT (DRIVER) SIDE SHOWN

