

## INSTALLATION INSTRUCTIONS AND PARTS LIST

### MODEL 415036, 36" GRIP STEPS (BOARDS ONLY)

1. READ INSTRUCTIONS COMPLETELY AND CHECK TO MAKE SURE THAT ALL REQUIRED PARTS (LISTED ON THE SERVICE PARTS LIST) ARE ON HAND BEFORE STARTING THE INSTALLATION.
2. FOLLOW THE INSTRUCTIONS INCLUDED WITH THE SPECIFIC BRACKET PACKAGE THAT YOU ARE USING TO MOUNT THE BRACKETS TO YOUR VEHICLE.
3. STEP ASSEMBLY:
  - 3.1 BEFORE ATTACHING THE GRIP STEPS TO THE BRACKETS, SLIDE THE APPROPRIATE NUMBERS OF SUPPORT BRACES (ITEM #2) INTO THE CHANNEL OF THE STEP (ITEM #1).
  - 3.2 SLIDE THE END CAP (ITEM #3) OVER THE FRONT AND REAR OF EACH STEP. USING THE SUPPLIED #8 X 1/2" SELF-DRILLING TEK SCREW (ITEM #8); SCREW THE END CAP TO THE BOTTOM OF THE STEP.
4. ATTACHING THE STEP TO THE MOUNTING BRACKETS:
  - 4.1 SET THE STEP ON THE MOUNTING BRACKETS, AND SLIDE EACH SUPPORT BRACE OVER THE TOP OF EACH MOUNTING BRACKET. ATTACH THE FLAT SPACER PLATE (ITEM #4) TO THE BOTTOM OF THE STEP, BETWEEN THE SUPPORT BRACE, AND THE TOP OF THE MOUNTING BRACKET.
  - 4.2 USING THE SUPPLIED 5/16-18 X 1" CARRIAGE BOLT, WASHER, AND FLANGE NUTS, (ITEM # 5, 6, 7), ATTACH THE STEP ASSEMBLY, FLAT SPACER PLATE AND MOUNTING BRACKET.
  - 4.3 SET THE STEP PLATE IN THE CORRECT POSITION AND TIGHTEN ALL FASTENERS. TORQUE ALL 5/16" FASTENERS TO 19 LB FT.

### SERVICE PARTS LIST

ITEM	PART NO.	QTY	DESCRIPTION
1	551699	2	EXTRUSION-AL,36.00, GRIP STEP,BLK,415036
2	551296	4	SUPPORT BRACE, UPPER, GALV
3	551394	4	CAP-END,GRIP STEP, BLACK, PLASTIC
4	551298	4	SPACER PLATE, LOWER, BLACK
5	108683	8	BOLT-CRG,5/16-18 X 1.0", SST
6	101369	8	WASHER-FLAT,5/16,SST
7	102680	8	NUT-SERR FLG,HX,SST,WX,5/16-18
8	107958	8	SCR-TEK #8-18 X 1/2",SST,BLK



(A LIVERNE Company)

SERVICE PARTS LIST

MODEL NO. - 415036

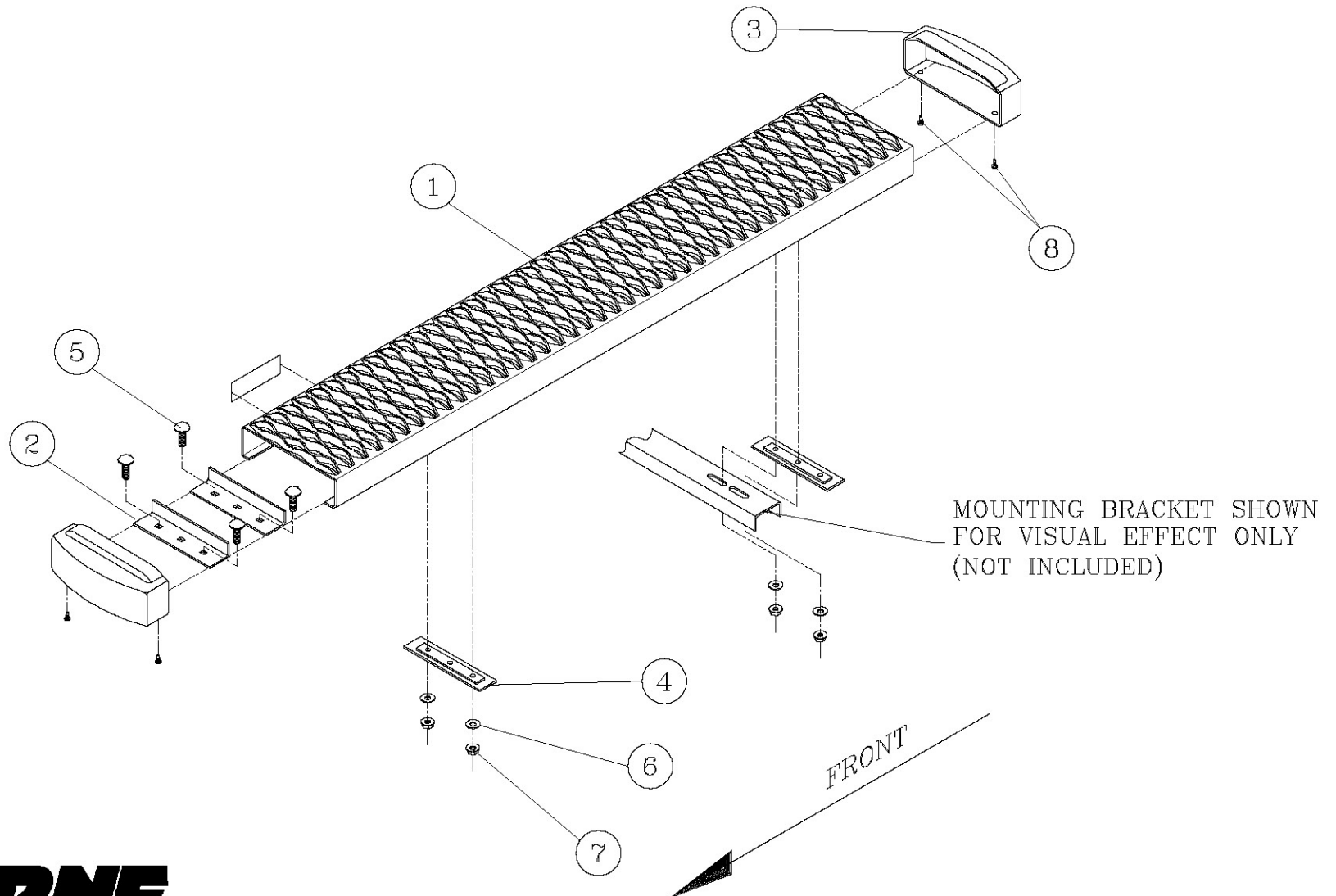

# INSTALLATION INSTRUCTIONS AND PARTS LIST

## FOR MOUNTING 400741 GRIP STEPS 2007-NEWER SPRINTER VANS

READ INSTRUCTIONS COMPLETELY AND CHECK TO MAKE SURE THAT ALL REQUIRED PARTS (LISTED ON SERVICE PARTS LIST) ARE ON HAND BEFORE STARTING THE INSTALLATION.

### **DRIVERS SIDE INSTALLATION**

1. PREASSEMBLE BRACKETS (ITEM 1) WITH SPACER BRACKETS (ITEM 7), USING THE 5/16-18 BOLTS WITH THE 5/16" WASHERS AND THE FLANGE NUTS (ITEMS 2, 9 & 10). FINGER TIGHTEN THEM ONLY AT THIS TIME.
2. ATTACHING THE FRONT BRACKET:
  - 2.1 ON THE BACK SIDE OF THE ROCKER PANEL, MEASURE ABOUT 9-1/2" BACK FROM THE FRONT OF THE MUD FLAP. IN THIS LOCATION THERE SHOULD BE A BODY PLUG
  - 2.2 IF THE TRUCK DOES NOT HAVE REAR A/C SCRAPE THE UNDER COATING OFF AROUND THE BODY PLUG AND REMOVE THE PLUG. THEN DRILL A 7/16" HOLE 1/2" TO THE FRONT OF THE BODY PLUG HOLE AND INSERT THE 5/16-18 U-NUT. (ITEM #3) PLACE BRACKET IN PLACE USING THE TOP SLOT AND FASTEN USING THE 5/16-18 BOLT AND WASHER. (ITEM # 2 & 9)
  - 2.3 IF THE TRUCK DOES HAVE REAR A/C YOU WILL NOT NEED TO REMOVE THE BODY PLUG INSTEAD PLACE THE PREASSEMBLED BRACKET INTO PLACE AND MARK THE HOLE LOCATION USING THE CENTER ROUND HOLE IN THE BRACKET AS A GUIDE. (MAKE SURE THAT THE BRACKET IS LEVEL WITH THE TRUCK) REMOVE THE BRACKET AND CENTER PUNCH THE MARKED HOLE AND DRILL WITH A 7/32 DRILL. PLACE BRACKET BACK IN PLACE AND INSTALL THE 1/4" SELF-TAPPING SCREW (ITEM #4). SEE FIG 1.
  - 2.4 ONCE THE BRACKET IS IN PLACE THE LOWER MOUNT IS READY TO BE DRILLED. USING A 11/32" DRILL BIT THE TWO HOLES IN THE LOWER BRACKET MOUNT CAN BE USED AS A DRILLING GUIDE.
  - 2.5 ONCE THE DRILLING IS DONE FASTEN THE BRACKET TO THE PINCH WELD USING THE SUPPLIED BLACK 5/16-18 BOLT AND 5/16 WASHER THROUGH THE DRILLED HOLES. ON THE BACK SIDE OF THE PINCH WELD PLACE THE RETAINER PLATE (ITEM #8) OVER THE BOLTS AND FASTEN THEM WITH THE SUPPLIED FLANGE NUT (ITEM #10), AND TIGHTEN DOWN ALL THE FASTENERS.
3. ATTACHING THE REAR BRACKET:
  - 3.1 ON THE BACK SIDE OF THE ROCKER PANEL, MEASURE ABOUT 27 1/2" BACK FROM THE FRONT OF THE MUD FLAP. THIS IS ABOUT WHERE THE SECOND BRACKET WILL BE INSTALLED.
  - 3.2 MEASURE THE HEIGHT OF THE FIRST BRACKET FROM THE TOP OF THE BRACKET TO THE BOTTOM OF THE FLOOR BOARD; THIS WILL HELP WITH MOUNTING THE BOARD LEVEL.
  - 3.3 USING THE BRACKET AS A GUIDE MARK THE HOLE USING THE TOP SLOT IN THE BRACKET. CENTER PUNCH AND DRILL USING A 7/32 DRILL BIT.
  - 3.4 POSITION THE BRACKET OVER THE HOLE JUST DRILLED AND FASTEN USING THE SUPPLIED SELF-TAPPING SCREW (ITEM #4). HAND TIGHTEN ONLY AT THIS TIME.
  - 3.5 WITH THE BRACKET IN PLACE REPEAT STEPS 2.4 & 2.5.



## **PASSANGER SIDE INSTALLATION**

1. PREASSEMBLE BRACKETS (ITEM #1) WITH SPACER BRACKETS (ITEM 7), USING THE 5/16-18 BOLTS WITH THE 5/16 WASHERS AND THE FLANGE NUTS (ITEMS 2, 9 & 10). FINGER TIGHTEN THEM ONLY AT THIS TIME.
2. ATTACHING THE BRACKETS WILL BE THE SAME AS THE DRIVERS SIDE, STEPS 2 THRU 3.

### **SERVICE PARTS LIST**

<b>ITEM</b>	<b>PART NO.</b>	<b>QTY</b>	<b>DESCRIPTION</b>
1	551941	4	BRACKET-MTG, SPRNTR, 12 GA, LH/RH
2	100034	8	WASHER-FL, 5/16, ZP
3	105541	2	NUT-U, MULTI THD, LG, 5/16-18, BLK
4	105537	3	SCR-HWH, TF, AB, SST, 5/16 X 1.00
5	106997	8	SCR-HHCAP, 5/16-18 X 1.00, SST, BZP
6	106998	8	WASHER-FL, 5/16, BZP
7	552288	4	SPACER BRACKET, 7 GA, LH/RH
8	552289	4	PLATE-RETAINER, GALV, 7 GA
9	100647	6	SCR-HEX HD, 5/16-18 X 1.00 STL, ZP
10	100178	12	NUT-HEX FLG, 5/16-18



SERVICE PARTS LIST

BRACKET NO. - 400741

fig.2

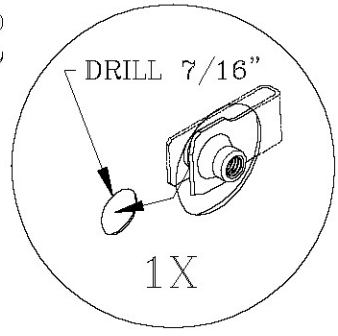

fig.1

