

INSTALLATION INSTRUCTIONS AND PARTS LIST

MODEL 415036, 36" GRIP STEPS (BOARDS ONLY)

1. READ INSTRUCTIONS COMPLETELY AND CHECK TO MAKE SURE THAT ALL REQUIRED PARTS (LISTED ON THE SERVICE PARTS LIST) ARE ON HAND BEFORE STARTING THE INSTALLATION.
2. FOLLOW THE INSTRUCTIONS INCLUDED WITH THE SPECIFIC BRACKET PACKAGE THAT YOU ARE USING TO MOUNT THE BRACKETS TO YOUR VEHICLE.
3. STEP ASSEMBLY:
 - 3.1 BEFORE ATTACHING THE GRIP STEPS TO THE BRACKETS, SLIDE THE APPROPRIATE NUMBERS OF SUPPORT BRACES (ITEM #2) INTO THE CHANNEL OF THE STEP (ITEM #1).
 - 3.2 SLIDE THE END CAP (ITEM #3) OVER THE FRONT AND REAR OF EACH STEP. USING THE SUPPLIED #8 X ½" SELF-DRILLING TEK SCREW (ITEM #8); SCREW THE END CAP TO THE BOTTOM OF THE STEP.
4. ATTACHING THE STEP TO THE MOUNTING BRACKETS:
 - 4.1 SET THE STEP ON THE MOUNTING BRACKETS, AND SLIDE EACH SUPPORT BRACE OVER THE TOP OF EACH MOUNTING BRACKET. ATTACH THE FLAT SPACER PLATE (ITEM #4) TO THE BOTTOM OF THE STEP, BETWEEN THE SUPPORT BRACE, AND THE TOP OF THE MOUNTING BRACKET.
 - 4.2 USING THE SUPPLIED 5/16-18 X 1" CARRIAGE BOLT, WASHER, AND FLANGE NUTS, (ITEM # 5, 6, 7), ATTACH THE STEP ASSEMBLY, FLAT SPACER PLATE AND MOUNTING BRACKET.
 - 4.3 SET THE STEP PLATE IN THE CORRECT POSITION AND TIGHTEN ALL FASTENERS. TORQUE ALL 5/16" FASTENERS TO 19 LB FT.

SERVICE PARTS LIST

ITEM	PART NO.	QTY	DESCRIPTION
1	551699	2	EXTRUSION-AL,36.00, GRIP STEP,BLK,415036
2	551296	4	SUPPORT BRACE, UPPER, GALV
3	551394	4	CAP-END,GRIP STEP, BLACK, PLASTIC
4	551298	4	SPACER PLATE, LOWER, BLACK
5	108683	8	BOLT-CRG,5/16-18 X 1.0", SST
6	101369	8	WASHER-FLAT,5/16,SST
7	102680	8	NUT-SERR FLG,HX,SST,WX,5/16-18
8	107958	8	SCR-TEK #8-18 X 1/2",SST,BLK



(A LIVERNE Company)

SERVICE PARTS LIST

MODEL NO. - 415036

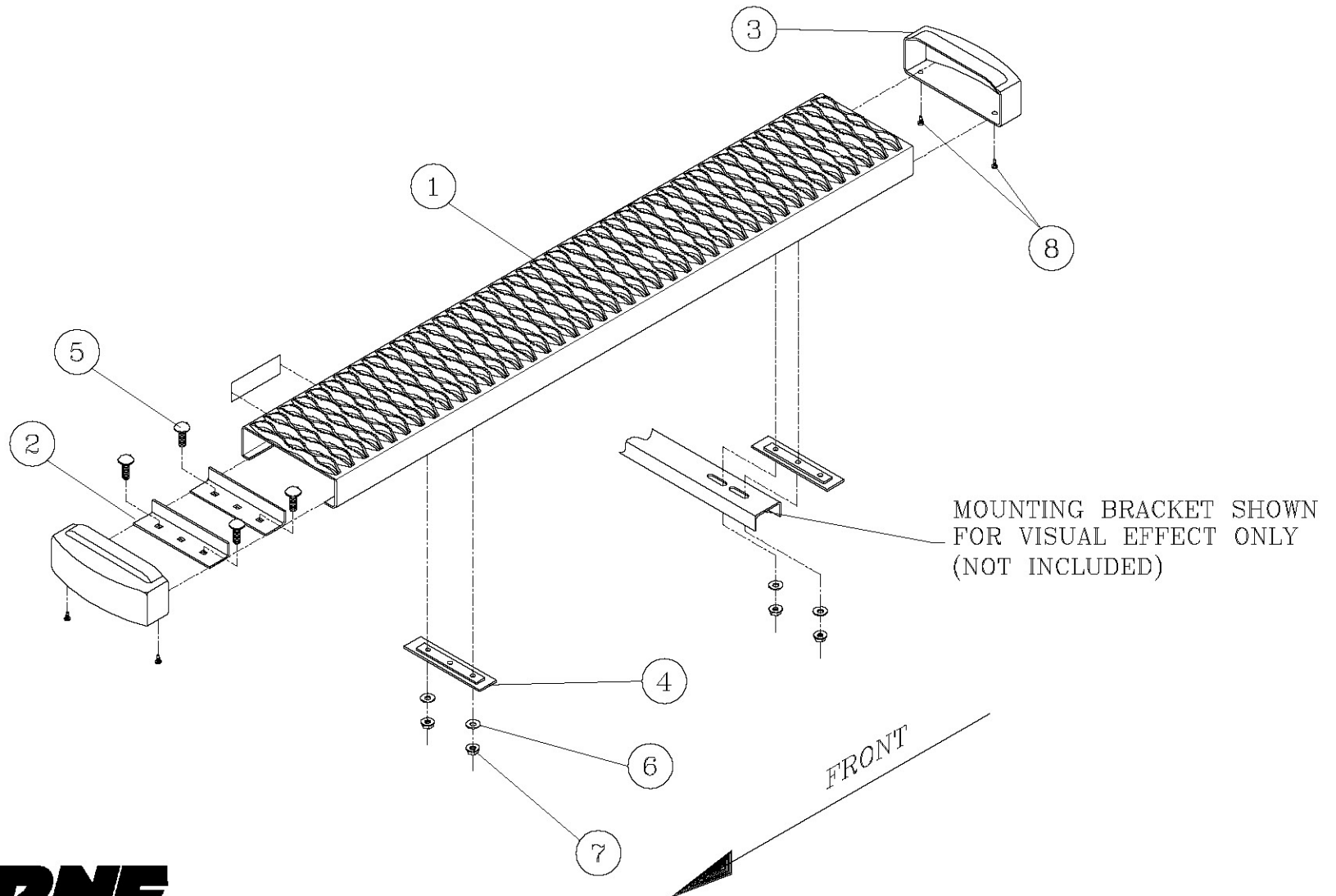

INSTALLATION INSTRUCTIONS AND PARTS LIST

MODEL 400341 GRIP STEPS

VEHICLE APPLICATION:

2003 AND NEWER CUT-A-WAY CHEVROLET EXPRESS AND GMC SAVANA VAN CHASSIS/CABS

READ INSTRUCTIONS COMPLETELY AND CHECK TO MAKE SURE THAT ALL REQUIRED PARTS (LISTED ON SERVICE PARTS LIST) ARE ON HAND BEFORE STARTING THE INSTALLATION

1. ON THE LEFT SIDE OF THE VEHICLE, REMOVE THE FRONT BODY MOUNTING BOLT. THE BOLT, STEEL WASHER AND RUBBER CUSHION WILL BE REUSED.
2. INSTALL THE MULTI-THREAD U-NUT (ITEM #9) ON THE FRONT MOUNTING BRACKET (ITEM #2). **(NOTE: INSTALL IN THE BOTTOM HOLE FOR CHASSIS CAB VANS.)**
3. INSTALL THE FRONT MOUNTING BRACKET (ITEM #2) TO THE FRONT BODY MOUNT WITH THE WASHER AND THE RUBBER CUSHION BETWEEN THE MOUNTING BRACKET AND THE BODY MOUNT. THE STEP END OF THE BRACKET SHOULD BE PERPENDICULAR TO THE OUTSIDE BODY. TIGHTEN THE BOLT TO 65 LB. FT.
4. INSTALL A 3/8"-16 SERRATED FLANGE NUT (ITEM #8) ON THE 3/8"-16 X 5" HEX BOLT (ITEM #6) WITH THE FLANGE FACING TOWARD THE END OF THE BOLT AND TURN ON JUST SHORT OF THE HEAD. SCREW THE BOLT INTO THE U-NUT AND WHEN IT COMES THROUGH THE OTHER SIDE START ANOTHER FLANGE NUT FACING THE SAME DIRECTION AS THE FIRST NUT. TURN THE NUT ON UNTIL THERE IS 3/4" PROTRUDING FROM THE FACE OF THE NUT, INSTALL A 3/8" FLAT WASHER (ITEM #12) AND THE .354 X 1.00 X .748 RUBBER WASHER (ITEM #10) INTO THE END OF THE BOLT. ADJUST THE LOAD REACTION BOLT ASSEMBLY SO THAT THE RUBBER CUSHION IS SNUG AGAINST THE FRAME AND TIGHTEN DOWN THE OUTSIDE FLANGE NUT. **(LOAD REACTION BOLT ASSEMBLY)** AS SHOWN IN *fig. 1*.
5. REMOVE THE SECOND BODY MOUNTING BOLT. THE BOLT, STEEL WASHER AND RUBBER CUSHION WILL BE REUSED.
6. INSTALL THE MULTI-THREAD U-NUT (ITEM #9) ON THE SECOND MOUNTING BRACKET (ITEM #4).
7. INSTALL THE SECOND MOUNTING BRACKET (ITEM #4) TO THE SECOND BODY MOUNT WITH THE WASHER AND THE RUBBER CUSHION BETWEEN THE MOUNTING BRACKET AND THE BODY MOUNT. THE STEP END OF THE BRACKET SHOULD BE PERPENDICULAR TO THE OUTSIDE BODY. TIGHTEN THE BOLT TO 65 LB. FT.
8. INSTALL A 3/8"-16 SERRATED FLANGE NUT (ITEM #8) ON THE 3/8"-16 X 3" HEX BOLT (ITEM #7) WITH THE FLANGE FACING TOWARD THE END OF THE BOLT AND TURN ON JUST SHORT OF THE HEAD. SCREW THE BOLT INTO THE U-NUT AND WHEN IT COMES THROUGH THE OTHER SIDE, INSTALL A .364 X .625 CAP PLUG (ITEM #11) ON THE END OF THE BOLT. ADJUST THE LOAD REACTION BOLT ASSEMBLY SO THAT THE RUBBER PLUG IS SNUG AGAINST THE FRAME AND TIGHTEN DOWN THE OUTSIDE FLANGE NUT. **(LOAD REACTION BOLT ASSEMBLY)** AS SHOWN IN *fig. 1*.
9. USING A 5/16"-1" BOLT (ITEM #14), 5/16" FLAT WASHER (ITEM #15), AND 5/16" FLANGE NUT (ITEM #16) INSTALL THE SUPPORT BRACE (ITEM #13) ON TO THE FRONT MOUNTING BRACKET (ITEMS #2,3). **NOTE: DO NOT TIGHTEN AT THIS TIME.**



10. ATTACH THE STEP BOARDS AS PER THE INSTRUCTIONS INCLUDED IN YOUR STEP BOARD KIT.
11. HOLD THE SUPPORT BRACE (ITEM # 13) UP TO THE STEP BOARD AND USING A 3/8" DRILL BIT DRILL A HOLE WHERE THE SUPPORT BRACE MEETS THE BOARD.
12. INSTALL A 5/16"-1" BOLT (ITEM #14), 5/16" FLAT WASHER (ITEM #15), AND 5/16" FLANGE NUT (ITEM #16) TO SECURE THE SUPPORT BRACE TO THE STEP BOARD.
13. TIGHTEN THE SUPPORT BRACE BOLTS TO 19 LB. FT.
14. REPEAT STEPS 1-13 FOR THE RIGHT SIDE OF VEHICLE.

ATTACHING THE STEP TO THE MOUNTING BRACKETS.

PLEASE REFER TO THE INSTRUCTION SHEET INCLUDED WITH YOUR GRIP STEP BOARDS TO MOUNT THE STEPS TO THE MOUNTING BRACKETS.

SERVICE PARTS LIST

ITEM	PART NO.	QTY	DESCRIPTION
1	415036	1	GRIP STEP BOARDS- 36.00" (MOD. 415036)
2	552522	1	MOUNTING BRACKET – LH, FRONT
3	552523	1	MOUNTING BRACKET – RH, FRONT (NOT SHOWN)
4	552525	1	MOUNTING BRACKET – REAR, LH
5	552526	1	MOUNTING BRACKET – REAR, RH (NOT SHOWN)
6	109474	2	SCREW – HEX HEAD CAP, 3/8"-16 X 5", FULL THREAD, ZP
7	109473	2	SCREW – HEX HEAD CAP, 3/8"-16 X 3", FULL THREAD, ZP
8	100181	6	NUT – SERRATED FLANGE, 3/8"-16, ZP
9	109258	4	U-NUT – MULTI THREAD, 3/8"-16 X 1.09"
10	102592	2	RUBBER WASHER - .354 X 1.00 X .748
11	103325	2	VINYL CAP PLUG - .364 X 5/8"
12	106962	2	WASHER – FLAT, 3/8, SST, BZP
13	552549	2	BRACE – SUPPORT, 400341
14	104281	4	SCREW-CAP, 5/16"-18 X .875"
15	100034	4	WASHER-FLAT, 5/16", ZP
16	100178	4	NUT-SERR FLANGE, 5/16"-18



SERVICE PARTS LIST

MODEL NO. - 400341

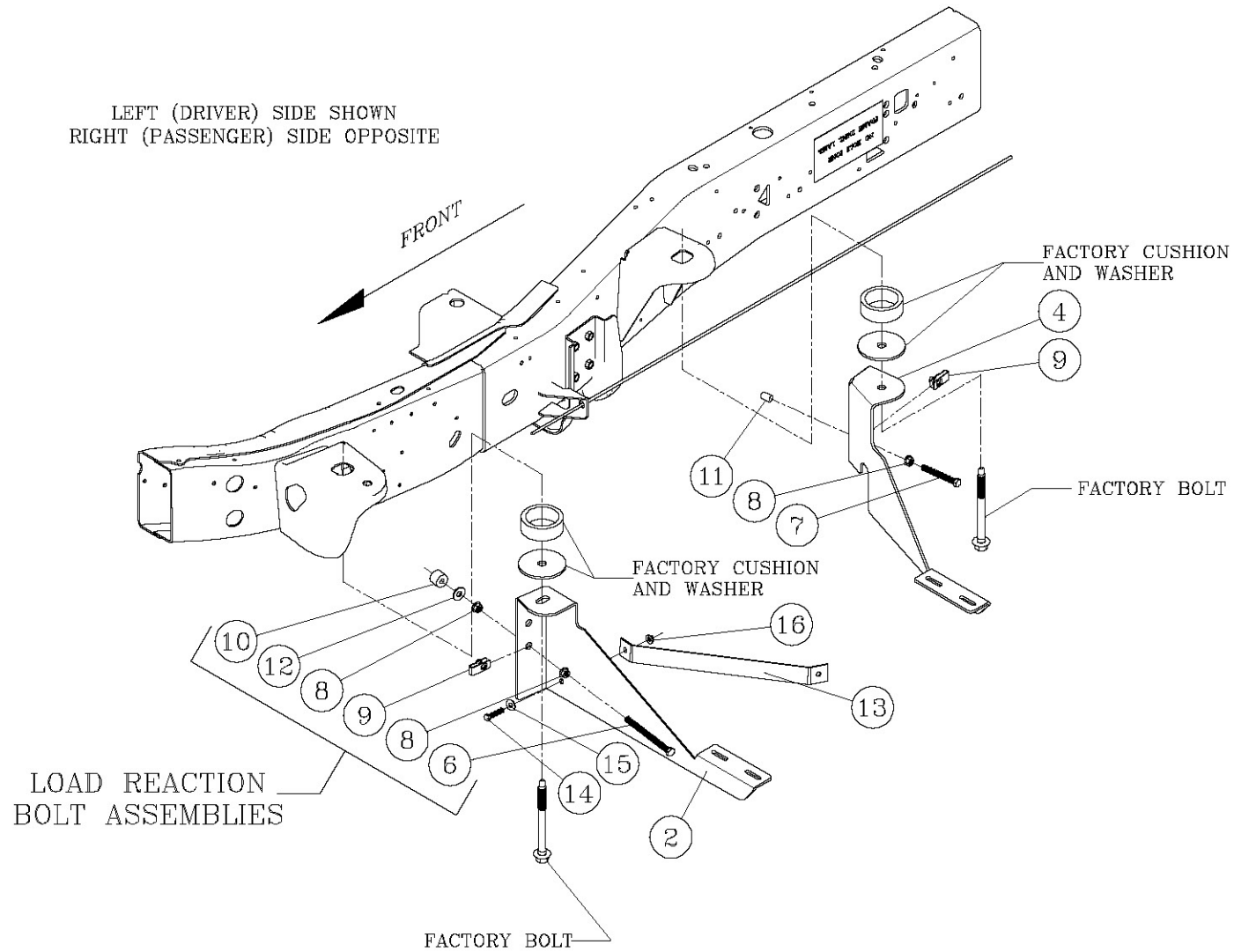

fig.1

