

Installation Instructions

4055142

Level of Difficulty

Easy

Parts List

1	Driver / left, running board*
1	Passenger / right, running board*
6	VersaTrac™ mounting bracket, universal
6	Serrated flange nut, M8
12	Hex bolt, M8 (S)
12	Flat washer, M8 (S)
12	Lock washer, M8 (S)
12	Hex bolt, M8 (B)
12	Flat washer, M8 (B)
12	Lock washer, M8 (B)
12	Hex nut, M8 (B)

(S) = Silver hardware

(B) = Black hardware

*Running boards sold separately

Tools Required

Ratchet	Level
Torque wrench	Socket set
Flathead screwdriver	

Torque Specifications

	Metric	SAE	
	M6 bolt		3 ft-lbs.
	M8 bolt		7 ft-lbs.
	M10 bolt		16 ft-lbs.
	M12 bolt		28 ft-lbs.
	1/4" bolt		3 ft-lbs.
	5/16" bolt		7 ft-lbs.
	3/8" bolt		16 ft-lbs.
	7/16" bolt		20 ft-lbs.
	1/2" bolt		28 ft-lbs.

Use above torque setting unless otherwise noted

Product Photo

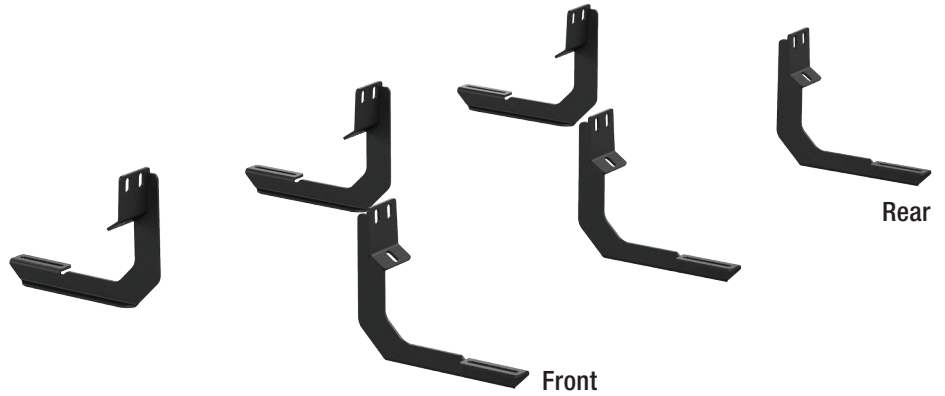

SlimGrip™ (not included)



Notes and Maintenance

Before you begin installation, read all instructions thoroughly.

Proper tools will improve the quality of installation and reduce the time required.

To protect the product, wax after installing. Regular waxing is recommended to add a protective layer over the finish. Do not use any type of polish or wax that may contain abrasives that could damage the finish.

For polished, gloss and other smooth finishes, polish may be used to clear small scratches and scuffs on the finish.

Mild automotive detergent may be used to clean the product. Do not use dish detergent, abrasive cleaners, abrasive pads, wire brushes or other similar products that may damage the finish.

Refer to the table to the left when securing hardware during the installation process to help prevent damage to the product or vehicle.

Step 1

Starting on the driver side, locate the four mounting tabs along the bottom edge of the vehicle body.

This installation will use the first, second and fourth mounting tabs.

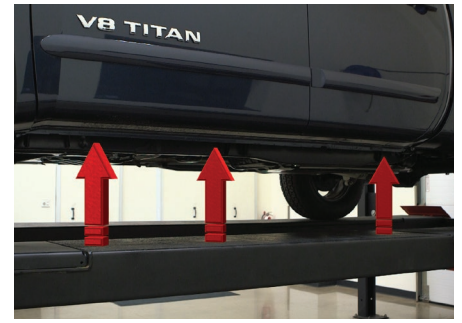
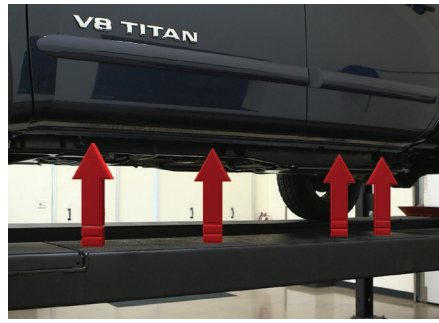

Step 2

Starting at the front driver-side mounting location, use a flathead screwdriver to remove the plastic plugs, exposing the threaded inserts on the rocker panel.

Note: Old-style vehicles may have a combination of threaded inserts and threaded studs. New-style vehicles will have two threaded inserts as shown.

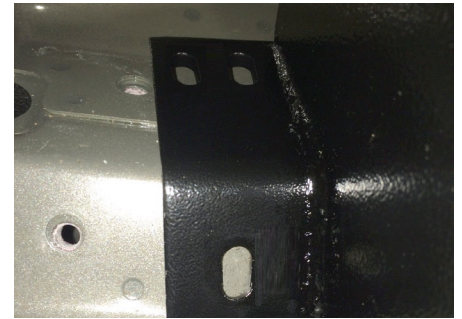

Step 3

Secure the bracket to the vehicle using an M8 serrated flange nut on the top mounting point and a silver M8 hex bolt, lock washer and flat washer on the lower mounting point.

On newer vehicles with two threaded inserts, install the bracket with two silver M8 hex bolts, lock washers and flat washers.

Snug the hardware, but do not fully tighten.

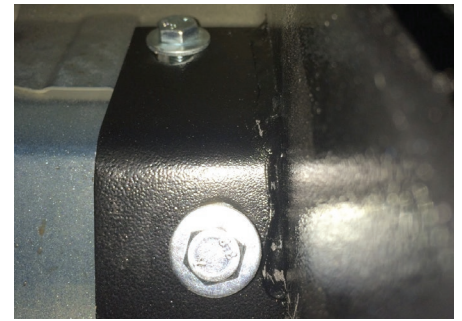

Step 4

Repeat steps 2 and 3 to install the middle and rear mounting brackets.



Step 5

Slide the three track mounting brackets into the bottom side of the SlimGrip™ board.



Step 6

Carefully place the running board onto the mounting brackets.

Align the track mounting brackets with the mounting brackets on the vehicle.



Step 7

Attach the track mounting brackets to the mounting brackets on the vehicle using black M8 hex bolts, hex nuts, lock washers and flat washers.



Step 8

At this time, adjust the running board to the desired location.

With the running board in position, it is recommended to tighten all brackets to the vehicle first, followed by the running board connections.

For recommended torque specifications, refer to the table on page one.



Step 9

Repeat steps 1 through 8 on the passenger side of the vehicle.

Congratulations on the installation of your new SlimGrip™ running boards.

With the running boards installed, periodic inspections should be performed to ensure all mounting hardware remains tight.

To protect your investment, see the 'Notes and Maintenance' section on the second page of this instruction manual.

