

INSTALLATION INSTRUCTIONS FOR MOUNTING

LUVERNE GRILLE GUARD WITH THE FOLLOWING MODEL NO.:
330931/330934 & 340931/340934 ON:

2009 AND NEWER DODGE RAM 1500 SERIES TRUCKS

1. READ THE INSTRUCTIONS COMPLETELY AND CHECK TO MAKE SURE THAT ALL OF THE REQUIRED PARTS ARE ON HAND BEFORE STARTING THE INSTALLATION. THE CARTON SHOULD CONTAIN:
 - (1) OUTER RING PACKAGE
 - (1) OUTER RING ASSEMBLY
 - (1) UPRIGHT PACKAGE
 - (1) UPRIGHT ASSEMBLY, LH
 - (1) UPRIGHT ASSEMBLY, RH
 - (1) MOUNTING BRACKET, TOW HOOK, LH
 - (1) MOUNTING BRACKET, TOW HOOK, RH
 - (2) MOUNTING BRACKET, FRAME
 - (2) MOUNTING BRACKET, BOTTOM
 - (2) UPRIGHT COVERS (**CHROME GUARDS ONLY**)
 - (1) HARDWARE PACKAGE
 - (1) CUSTOMER SERVICE PACKAGE

REFER TO SHEETS #1 - #7 FOR GUARD ASSEMBLY & INSTALLATION INSTRUCTIONS 2-10 WITH TOW HOOKS OR 1-11 WITHOUT TOW HOOKS

MOUNTING THE GUARD ON VEHICLES WITH TOW HOOKS

2. REMOVE THE TWO NUTS THAT SECURE THE FORWARD PART OF THE TOW HOOKS TO THE FRAME. THESE NUTS WILL BE REUSED.
3. INSERT THE TOW HOOK MOUNTING BRACKETS (ITEM #4 & #5) INTO THE HOLES IN THE FACE OF THE BUMPER WHERE THE TOW HOOKS PROTRUDE FROM THE BUMPER. RAISE THE BOLT ASSEMBLYS TO ALLOW THE HOLES IN THE BRACKET TO ALIGN WITH THE HOLES IN THE TOW HOOK AND LOWER THE BOLT BRACKET INTO THE HOLES. REINSTALL THE NUTS ON THE BOLTS. LEAVE LOOSE AT THIS TIME
4. INSTALL THE UPRIGHTS (ITEM #2 & #3) ONTO THE MOUNTING BRACKETS (ITEM #4 & #5) WITH THE 7/16"-14 X 1-1/4" HEX BOLTS (ITEM #14). LEAVE LOOSE AT THIS TIME.
5. POSITION ONE OF THE BOTTOM MOUNTING BRACKETS (ITEM #7) SO THAT THE HOLES IN THE BRACKET LINE UP WITH THE HOLE IN THE BOTTOM OF THE UPRIGHT AND THE BOLT IN THE BOTTOM OF THE TOW HOOK MOUNTING HORN HANGING DOWN FROM THE FRAME AND MARK THE AIR DAM WHERE THE MOUNTING BRACKET WILL NEED TO PASS THROUGH THE LOWER LIP OF THE AIR DAM.

NOTE: OPTIONAL METHOD OF ALTERING THE LOWER AIR DAM IS TO NOTCH OUT THE SHORT FLANGE ON THE BOTTOM OF THE AIR DAM AND ALLOW THE MAIN PORTION OF THE AIR DAM TO REST ON TOP OF THE BRACKETS.



6. REMOVE THE BOLTS FASTENING THE REAR OF THE TOW HOOK TO THE FRAME AND INSTALL THE 7/16"-14 X 1-1/2" HEX BOLTS (ITEM #13), 7/16" LOCK WASHERS (ITEM #20) AND 7/16" FLAT WASHERS (ITEM #22) IN THE UPRIGHT SIDE OF THE BRACKET AND THEN REINSTALL THE M12 X 1.5 HEX BOLTS INTO THE REAR OF THE TOW HOOK BRACKET. LEAVE LOOSE AT THIS TIME.
7. INSTALL THE GRILLE GUARD RING ON TO THE UPRIGHTS AND FASTEN WITH THE 7/16"-14 X 1-1/4" HEX BOLTS (ITEM #14), 7/16" FLAT WASHERS (ITEM #23) AND THE UPRIGHT COVERS (ITEM #26) (**CHROME GUARDS ONLY**). LEAVE LOOSE AT THIS TIME.
8. MAKE SURE THAT THE BACK EDGES OF THE UPRIGHTS ARE PARALLEL TO THE RING BAR AND THERE IS EQUAL GAP ON EACH SIDE OF THE BAR AND THE INSIDE OF THE UPRIGHT. TIGHTEN THE BOLTS TO 54 FT LBS.
9. CHECK THAT THE GRILLE GUARD IS CENTERED AND VERTICAL ON THE BUMPER AND TIGHTEN THE 7/16"-14 X 1-1/4" HEX BOLTS (ITEM #14) TO 54 FT LBS.
10. TIGHTEN THE 7/16"-14 X 1-1/2" HEX BOLTS (ITEM #13) AND THE FACTORY M12 X 1.5 HEX BOLTS IN THE BOTTOM BRACES TO 54 FOOT-POUNDS OF TORQUE.

MOUNTING THE GUARD ON VEHICLES WITHOUT TOW HOOKS

1. REMOVE THE TWO LOWER NUTS THAT HOLD THE BUMPER TO THE FRAME ON EACH SIDE.
2. INSTALL THE TWO FRAME MOUNTING BRACKETS (ITEM #6) TO THE FRAME PLATES ON THE END OF THE FRAME USING THE 1/4"-20 X 3/4" HEX BOLTS (ITEM #27) TO ALIGN THE BRACKETS WITH THE FRAME.
3. REINSTALL THE FACTORY NUTS ON THE BOLTS AND TIGHTEN TO 70 FT LBS.
4. INSERT THE TOW HOOK MOUNTING BRACKETS (ITEM #4 & #5) INTO THE HOLES IN THE FACE OF THE BUMPER WHERE THE TOW HOOKS PROTRUDE FROM THE BUMPER AND FASTEN TO THE FRAME MOUNTING BRACKETS WITH THE 1/2"-13 X 1-1/4" HEX BOLTS (ITEM #11), 1/2" FLAT WASHERS (ITEM #21) AND 1/2"-13 SERRATED FLANGE NUTS (ITEM #18). LEAVE LOOSE AT THIS TIME.

NOTE: IF THE VEHICLE DOES NOT HAVE TOW HOOKS THE RECESSED PORTION IN THE BUMPER FILLER WILL HAVE TO BE CUT OUT.

5. INSTALL THE UPRIGHTS (ITEM #2 & #3) ONTO THE MOUNTING BRACKETS (ITEM #4 & #5) WITH THE 7/16"-14 X 1-1/4" HEX BOLTS (ITEM #14). LEAVE LOOSE AT THIS TIME.
6. SEE STEP #5 AND NOTE ON PAGE 1.
7. INSTALL THE 7/16"-14 X 1-1/2" HEX BOLTS (ITEM #13), 7/16" LOCK WASHERS (ITEM #20) AND 7/16" FLAT WASHERS (ITEM #22) IN THE UPRIGHT SIDE OF THE BRACKET AND THE M12 X 1.5 X 65mm HEX BOLTS (ITEM #12), 1/2" LOCK WASHERS (ITEM #19), 7/16" FLAT WASHERS (ITEM #22) AND 1.375 SPACER (ITEM #24) INTO THE REAR OF THE TOW HOOK BRACKET. LEAVE LOOSE AT THIS TIME.
8. INSTALL THE GRILLE GUARD RING ON TO THE UPRIGHTS AND FASTEN WITH THE 7/16"-14 X 1-1/4" HEX BOLTS (ITEM #14), 7/16" FLAT WASHERS (ITEM #23) AND THE UPRIGHT COVERS (ITEM #26) (**CHROME GUARDS ONLY**). LEAVE LOOSE AT THIS TIME.



9. MAKE SURE THAT THE BACK EDGES OF THE UPRIGHTS ARE PARALLEL TO THE RING BAR AND THERE IS EQUAL GAP ON EACH SIDE OF THE BAR AND THE INSIDE OF THE UPRIGHT. TIGHTEN THE BOLTS TO 54 FT LBS.
10. CHECK THAT THE GRILLE GUARD IS CENTERED AND VERTICAL ON THE BUMPER AND TIGHTEN THE 7/16"-14 X 1-1/4" HEX BOLTS (ITEM #14) TO 54 FT LBS.
11. TIGHTEN THE 7/16"-14 X 1-1/2" HEX BOLTS (ITEM #13) AND THE FACTORY M12 X 1.5 HEX BOLTS IN THE BOTTOM BRACES TO 54 FOOT-POUNDS OF TORQUE.

SERVICE PARTS LIST

ITEM	PART NO.	QTY	DESCRIPTION
1	202593	1	RING WELDMENT – CHROME
1	202598	1	RING WELDMENT – BLACK
2	202580	1	UPRIGHT WELDMENT – CHROME, LH
2	202595	1	UPRIGHT WELDMENT – BLACK, LH
3	202581	1	UPRIGHT WELDMENT – CHROME, RH
3	202596	1	UPRIGHT WELDMENT – BLACK, RH
4	202586	1	MOUNTING BRACKET – TOW HOOK, LH
5	202587	1	MOUNTING BRACKET – TOW HOOK, RH
6	202588	2	MOUNTING BRACKET - FRAME
7	202589	2	MOUNTING BRACKET - BOTTOM
8	201122	4	TAPPING BAR – 13.000"
9	202191	1	RUBBER EXTRUSION – MACHINED, RH, 202176
10	202192	1	RUBBER EXTRUSION – MACHINED, LH, 202176
11	100086	4	HEX HEAD SCREW – 1/2"-13 X 1-1/4", ZP
12	109271	2	HEX HEAD SCREW – M12 X 1.5 X 65mm, ZP
13	100070	2	HEX HEAD SCREW - 7/16"-14 X 1-1/2", ZP
14	105939	8	HEX HEAD SCREW - 7/16"-14 X 1-1/4", SST
15	103715	12	SELF TAPPING SCREW – 1/4"-20 X 5/8", ZP
16	100006	2	HEX HEAD SCREW – 1/4"-20 X 3/4", ZP
17	100083	10	CAPTIVE NUT – 7/16"-14, BLACK
18	100123	4	HEX FLANGE NUT – 1/2"-13, ZP
19	100121	4	LOCK WASHER – 1/2", ZP
20	100078	2	LOCK WASHER – 7/16", ZP
21	100118	4	FLAT WASHER – 1/2", ZP
22	100081	4	FLAT WASHER – 7/16", ZP
23	103286	4	FLAT WASHER – 7/16", SST
24	109270	2	MOUNTING BRACKET SPACER - BOTTOM
25	108562	4	HOT TOPPERS - CHROME
25	108563	4	HOT TOPPERS - BLACK
26	202548	2	UPRIGHT COVERS (CHROME GUARDS ONLY)
27	100006	2	HEX HEAD SCREW – 1/4"-20 X 3/4", ZP
28	100252	1	DECAL – LOGO, 1 X 3



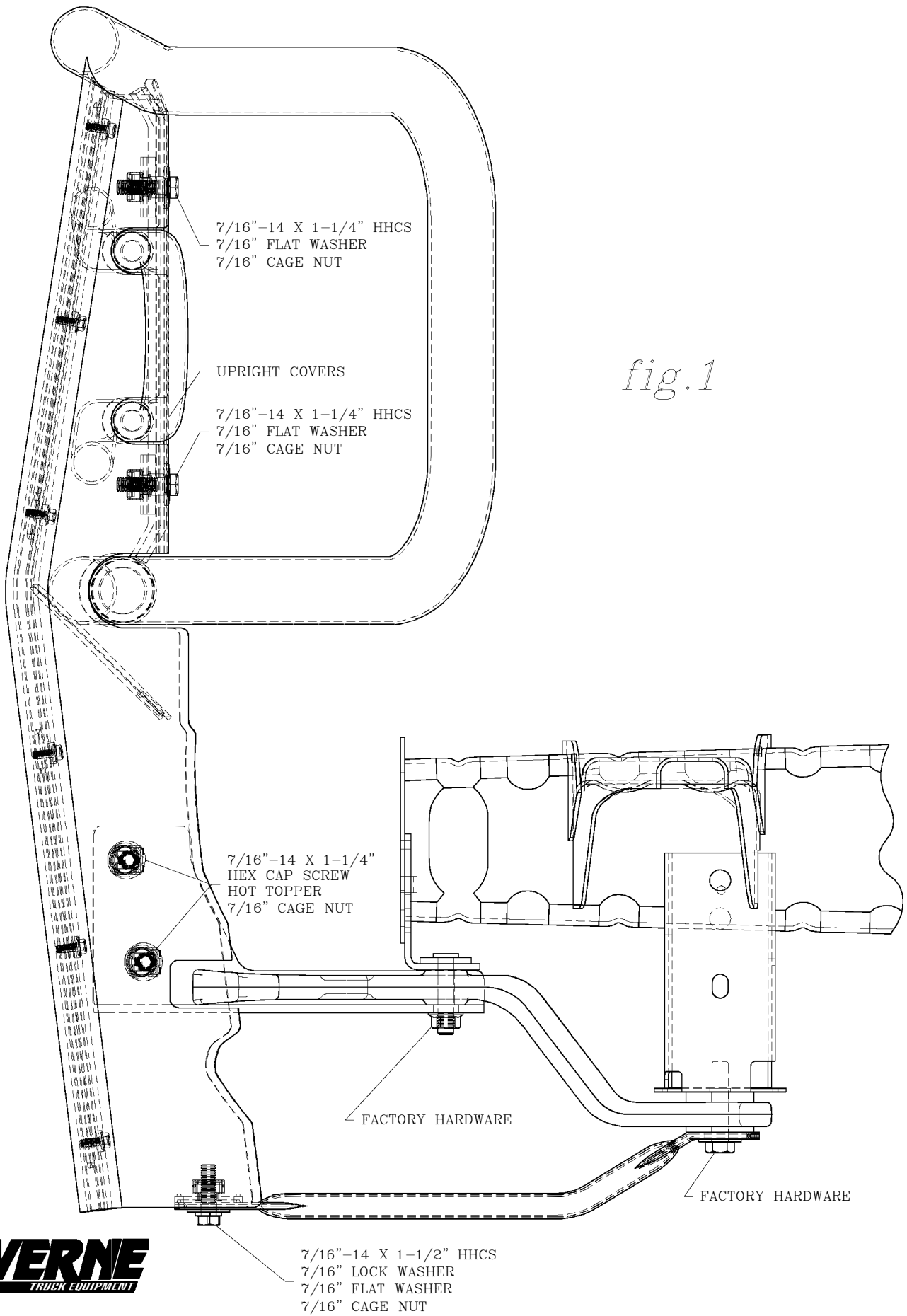

fig.1

SERVICE PARTS LIST

MODEL NO. - 330931/330934
 MODEL NO. - 340931/340934

INSTALLATION ON VEHICLES WITH TOW HOOKS

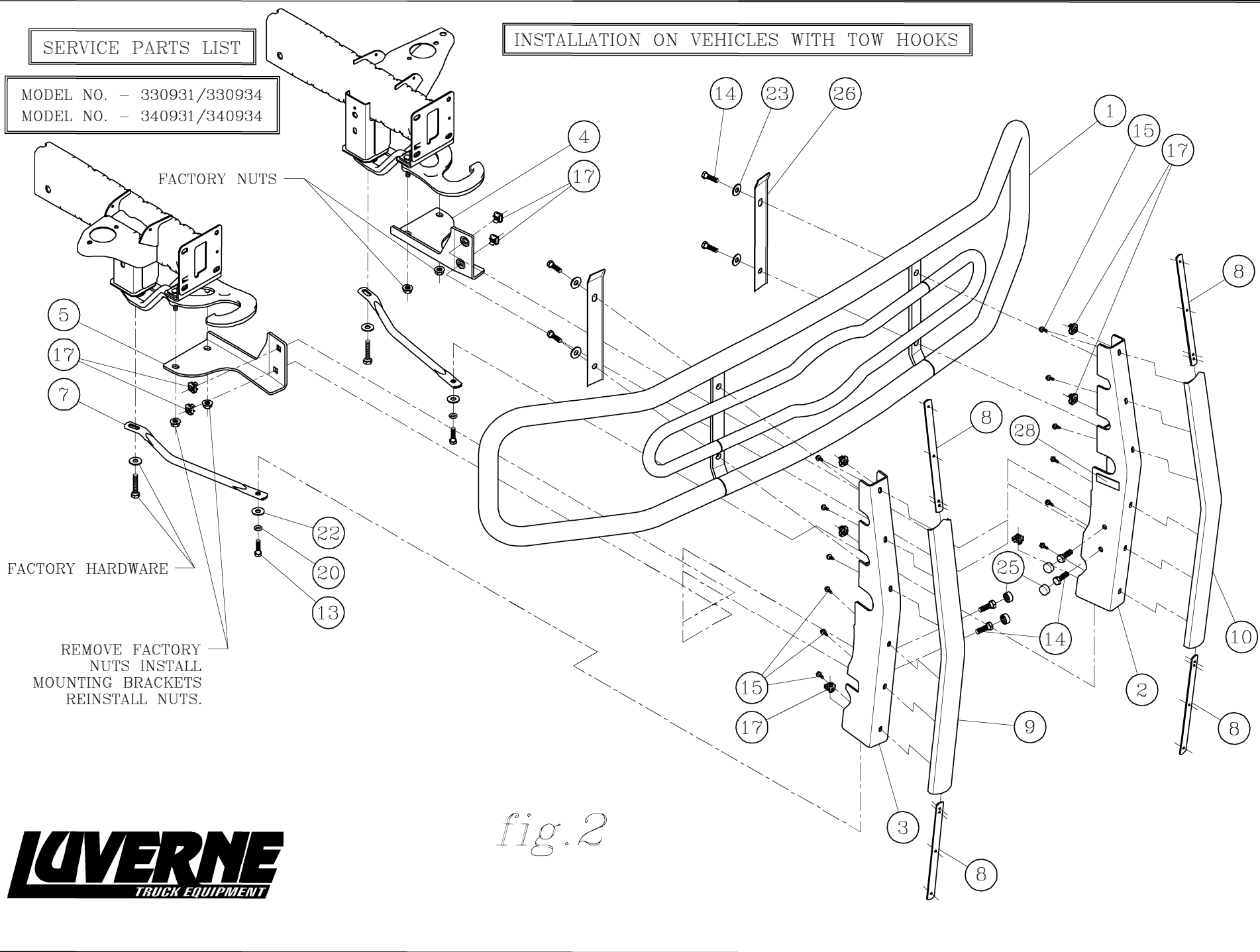

fig.2



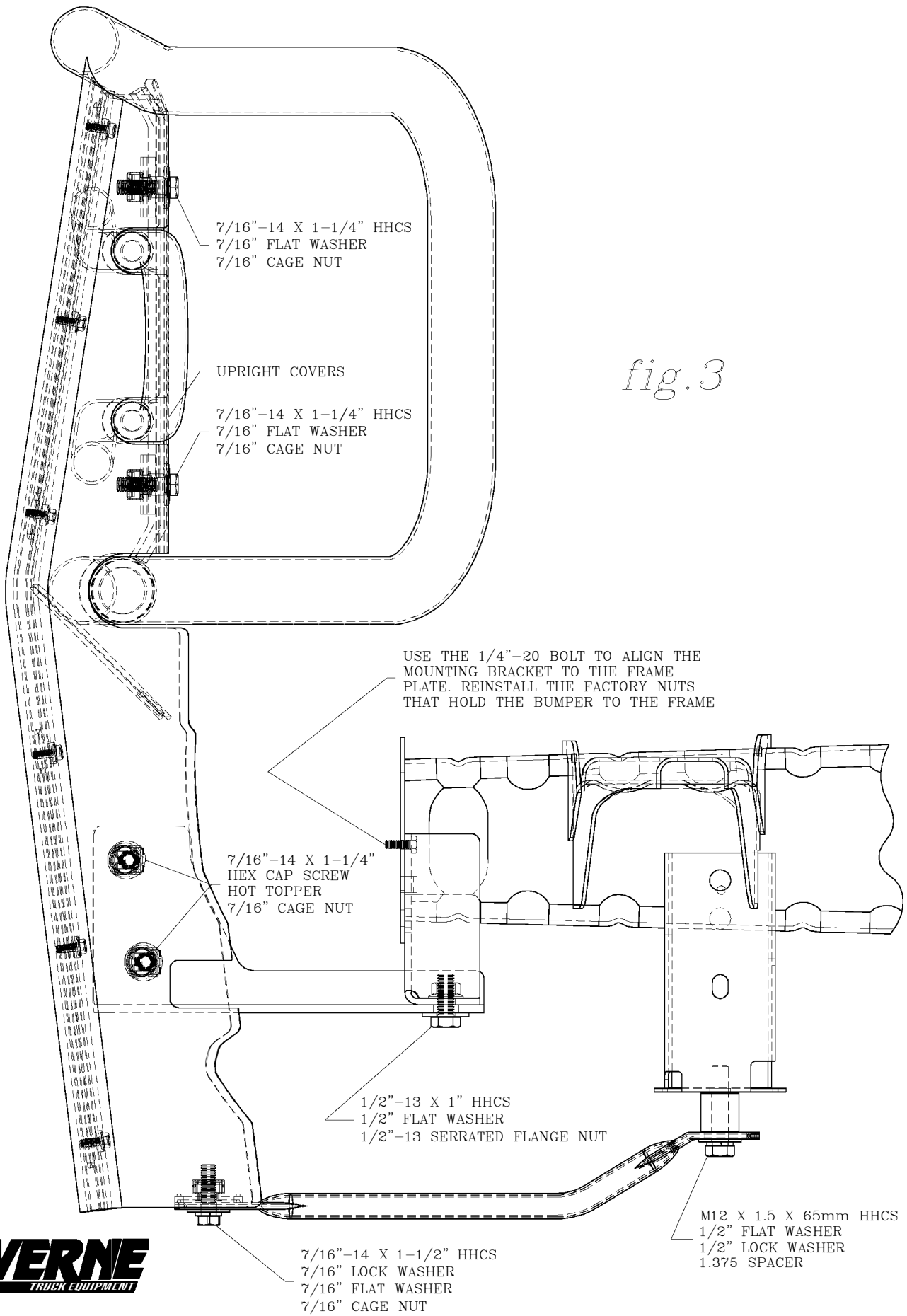

fig.3

SERVICE PARTS LIST

MODEL NO. - 330931/330934
MODEL NO. - 340931/340934

INSTALLATION ON VEHICLES WITHOUT TOW HOOKS

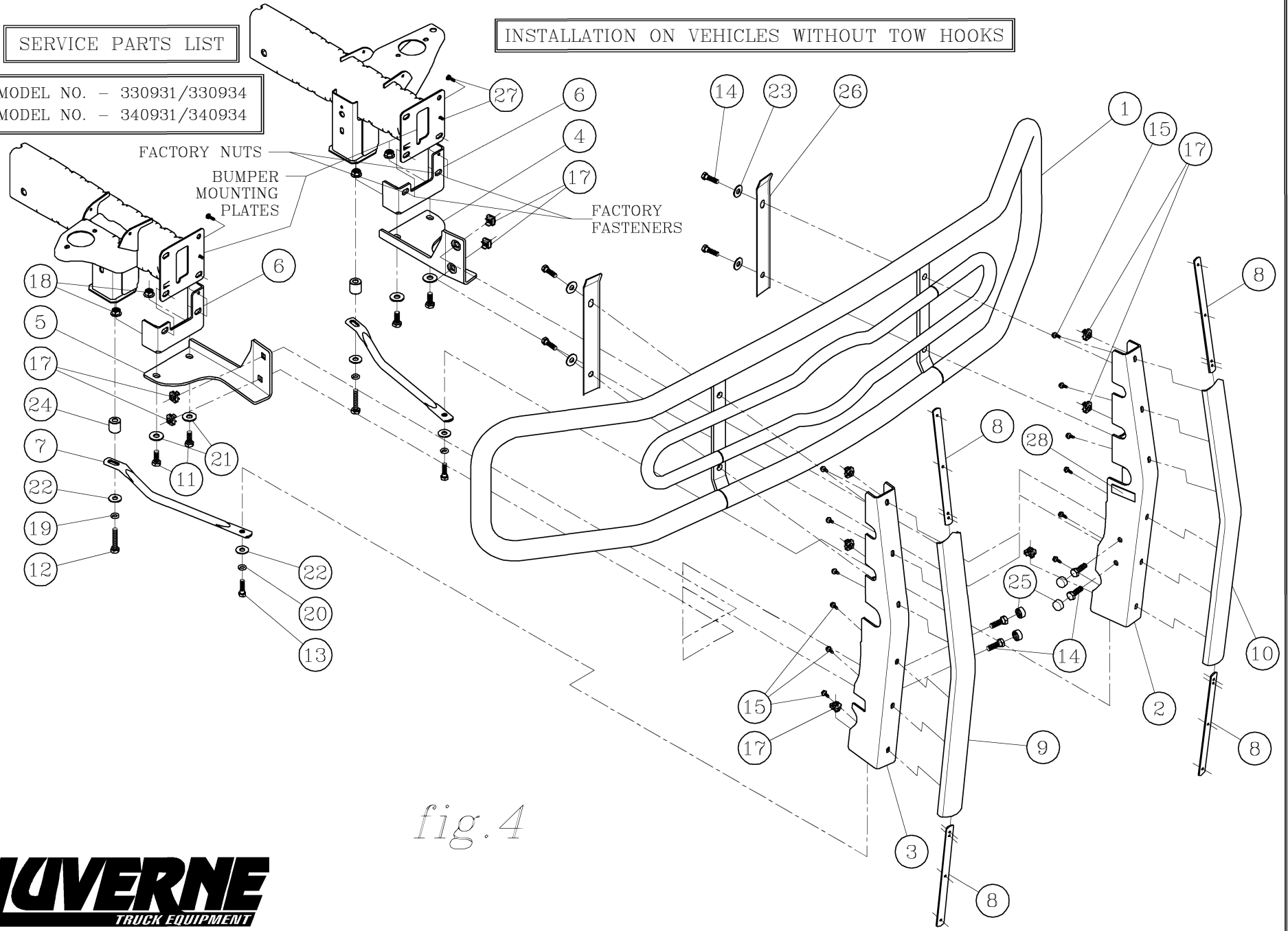

fig. 4

